

DETAIL FIG. 3A

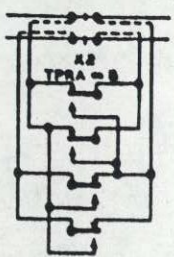

- NOTE 1 - LINE CIRCUIT TO CONTROL APPROACH SIGNAL TO ITS MOST RESTRICTIVE ASPECT
- 2 - X DENOTES CONTACTS OF 2 POSITION POINT DETECTOR LOCATED IN APPROVED TYPE SWITCH MACHINE OR 2 POSITION CIRCUIT CONTROLLER ATTACHED TO NORMALLY CLOSED SWITCH POINT (A) CONTACT OPEN WHEN SWITCH POINT IS OPEN  $\frac{1}{8}$  INCH (B) CONTACT CLOSED WHEN SWITCH POINT IS OPEN  $\frac{1}{8}$  INCH
- 3 - HEAVY DUTY CIRCUIT CONTROLLERS AND POINT DETECTORS SHALL BE USED IN ELECTRIFIED TERRITORY TO SHUNT TRACK.
- 4 - IN FIG. 2 USE AC TRACK CIRCUITS ONLY IN ELECTRIFIED TERRITORY IN NON-ELECTRIFIED TERRITORY USE DC TRACK CIRCUITS AS SHOWN IN FIG. 1 WITH MAIN TRACK CIRCUITS AS SHOWN IN DETAIL FIG. 3A.
- 5 - WHEN REQUIRED IN TCS TERRITORY ELECTRICAL LOCKS FOR CROSSOVER BETWEEN MAIN TRACK AND NON SIGNALLED SIDE TRACK WILL APPLY TO BOTH SWITCHES
- 6 - CIRCUIT CONTROLLERS WILL NOT BE APPLIED TO DERAILS (LEFT OR SPLIT POINT) EXCEPT AS REQUIRED BY STATE REGULATIONS
- CROSSOVERS LEFT OR RIGHT HAND EITHER END FACING OR TRAILING TURNOUTS-LEFT OR RIGHT HAND FACING OR TRAILING

SHEET 1 OF 2

CS 3000

**PENN CENTRAL**  
TYPICAL CIRCUITS  
NON-INTERLOCKED HAND OPERATED SWITCH  
AND DERAIL PROTECTION

OFFICE OF CHIEF ENGR. C. & S. PHILADELPHIA, PA. FEB. 14, 1972

APPROVED

*J. E. ...*  
CHIEF ENGINEER C & S

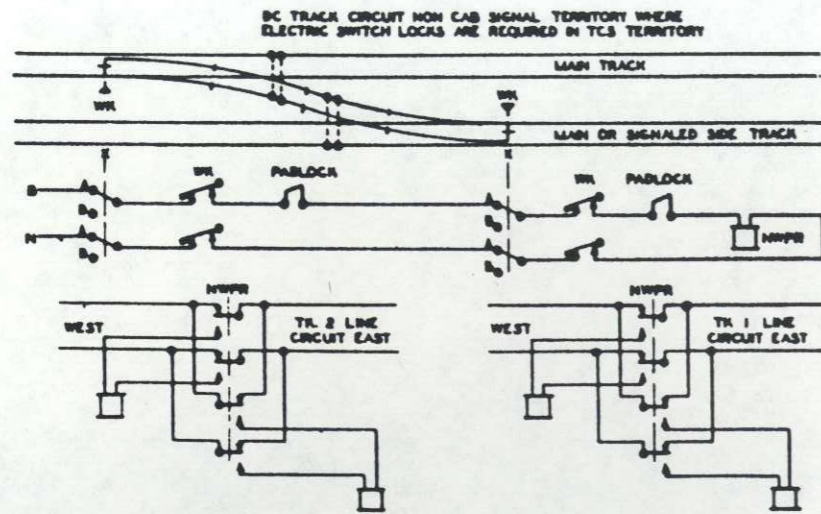

FIG. 5

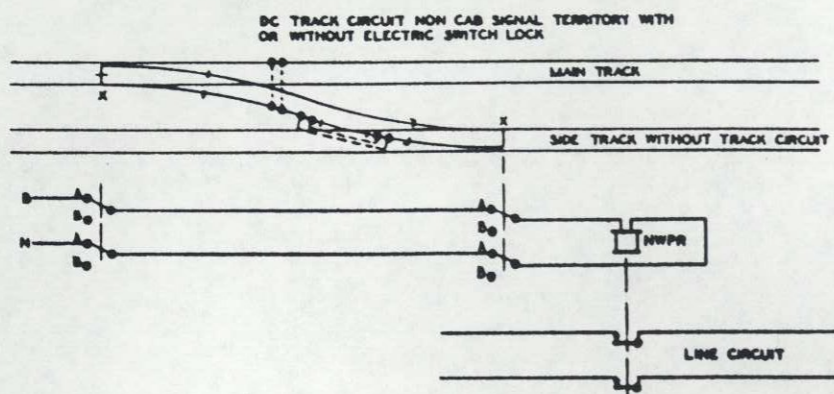

FIG. 7

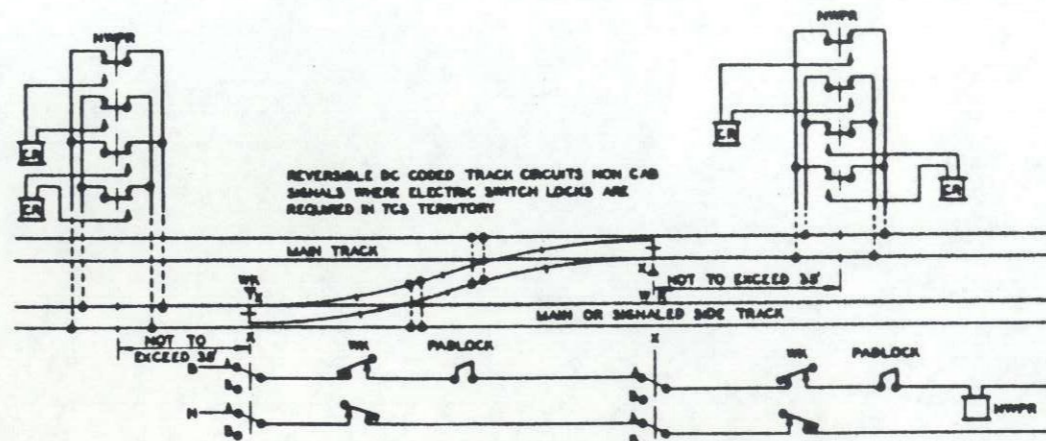

FIG. 6

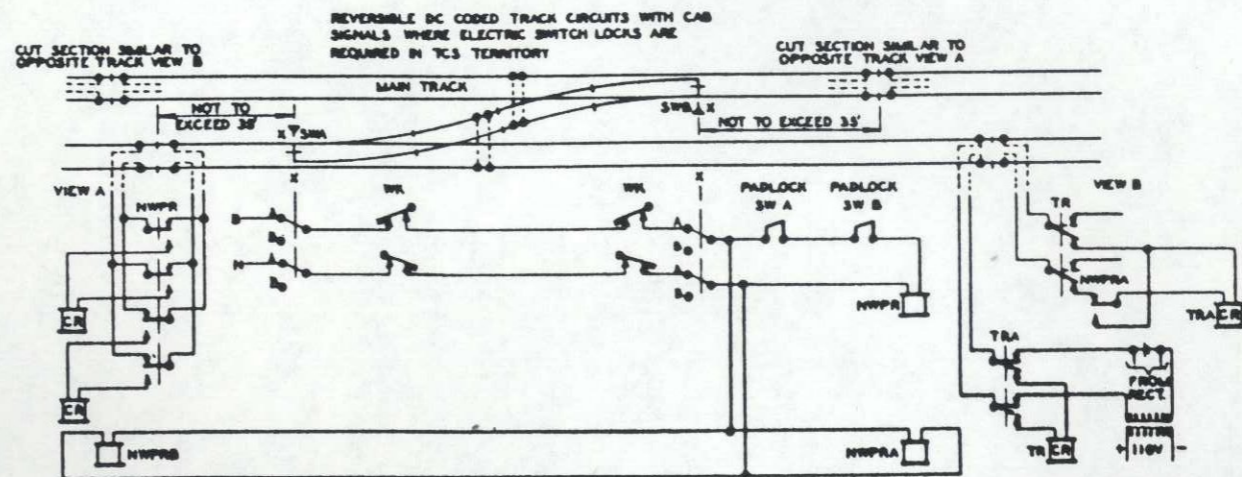

FIG. 8

SHEET 2 OF 2

C S 3000

**PENN CENTRAL**

TYPICAL CIRCUITS  
NON-INTERLOCKED HAND OPERATED SWITCH  
AND DERAIL PROTECTION

OFFICE OF CHIEF ENGR. C & S PHILADELPHIA PA.

FEB 14, 1972