

MAGNETIC  
SIGNAL  
CO.



C a t a l o g u e C

# MAGNETIC WIG WAG CROSSING FLAGMAN

---

Signal Accessories  
*and*  
Supplies

---

## MAGNETIC SIGNAL CO.

GENERAL OFFICES AND FACTORY

1334 EAST SIXTH STREET  
LOS ANGELES

BRANCH OFFICES

30 CHURCH STREET, NEW YORK

RAILWAY EXCHANGE, ST. LOUIS

RAILWAY EXCHANGE, CHICAGO

METROPOLITAN BANK BLDG., WASHINGTON, D. C.

FOREIGN OFFICES

Holland

Italy

Norway

Australia

Argentina

Canada

Cable Address

"MAGSIG"

# Index Catalogue "C"

A. C. FLAGMAN	PAGE
Description .....	23
Drawing .....	24
Parts for A. C. Flagman.....	25
Brake Parts for A. C. Flagman.....	22
A. C. Flagman Circuits.....	45
A. C. Track Circuits .....	49
Bases, Pole .....	35
Batteries, Primary .....	*
Battery Connectors .....	*
Battery Housings .....	34
Battery Renewals .....	*
Binding Posts .....	41
Bond Wires .....	*
Boxes, Relay .....	40
Brackets, Offset, for Wigwags.....	36
Bracket Parts .....	36
Brake Attachment .....	22
Brake Parts .....	22
Brush Contacts .....	49
Cable Entrances .....	35
Center of Street Installations.....	10, 11, 12, 35
Circuits, Flagman .....	42-49
Contact Parts for Flagmen.....	20
Contacts, Trolley Brush.....	49
Contacts, Track .....	34
Description of Standard Flagman.....	17
Description of A. C. Flagman.....	23
Description of Out-of-Order Attachment..	27
Description of 3 Position Flagman.....	31
Direct Current Track Circuits.....	43-46
DRAWINGS	
JH-8 Flagman, Standard 8-Volt.....	18
JH-26 Contact Parts for Flagman.....	20
JH-100 Two Position Flagman.....	21
JH-600 Parts 600-Volt Flagman.....	26
KC-200 Type KC Brake Mechanism....	22
LB-8 Three Position Flagman.....	30
MB A. C. Flagman with Coil Cut Out..	24
OA-8 Auxiliary "Out-of-Order" Signal..	28
U-100 Upper Quadrant Flagman.....	21
ELECTRIC LINE INSTALLATIONS	
British Columbia Electric Railway....	13
Interstate Public Service Co.....	7
Milwaukee Northern Railroad.....	13
Pacific Electric Railroad.....	15
Victorian Railways .....	9
Flags .....	35
Fusticlo Track Instruments.....	34
INSTALLATIONS	
Atchison, Topeka & Santa Fe Ry.....	5-6
British Columbia Electric Rys.....	13
Copper River & Northwestern Ry., Alaska.....	9
Interstate Public Service Co.....	7
Kansas City Southern Railway.....	10
Long Island Railroad Co.....	14
Louisville & Nashville R.R.....	7
Milwaukee Northern Railroad.....	13
Missouri Pacific Railroad.....	12

INSTALLATIONS—Continued	PAGE
Northern Pacific Railroad .....	6
Pacific Electric Railroad .....	15
Southern Pacific Co.....	5
Union Pacific Railroad Co.....	8, 11
Victorian Railways .....	9
Western Pacific Railroad .....	12
Wheeling & Lake Erie R.R.....	8
Installation Instructions .....	50-52
Instrument Cases, Cast Iron.....	34-35
Instrument Cases, Wood.....	40
Instrument Case Wiring Diagrams.....	42
Instrument Case Parts .....	40-41
Interlocking Relays .....	*
List of Users .....	4
Lower Quadrant Flagman.....	21, 35
Lubrication of Flagmen .....	51
Maintenance Instructions .....	50-52
Offset Brackets for Flagmen.....	36
Out-of-Order Signal .....	27-29
Out-of-Order Signal Wiring Diagrams....	44
PART LISTS	
JH-8 Flagman .....	19
JH-26 Contact .....	20
JH-600 600-Volt Flagman Parts.....	26
KC-8 Brake Mechanism.....	22
LB-8 Three Position Flagman.....	31-32
MB A. C. Flagman.....	25
OA-8 Out-of-Order Mechanism .....	29
PA A. C. Brake Parts.....	22
502 Simplex Relay.....	39
Coil Cut Out Parts .....	25
340 Instrument Case.....	40-41
Offset Bracket .....	36
Poles (For Mounting Flagmen).....	35
Pole Bases .....	35
Pole Steps .....	35
Relays, Flashing .....	*
Relays, Interlocking .....	*
Relays, High Voltage.....	37
Relays, Line .....	*
Relays, Neutral Track.....	*
Relays, Simplex .....	37
Relays, Time Element.....	*
Relay Boxes .....	34, 40
Resistors, Signal, Vitreous Enameled....	40-41
Resistors, Multiple Coil for Track Circuits	*
Simplex Relays .....	37-39
Steps, Pole .....	35
Terminal Blocks, A.R.A.....	41
Time Element Relays .....	*
Three Position Flagman .....	30-33
Three Position Flagman Circuits.....	46
Track Instruments .....	34
Track Instrument Control Circuits.....	48
Trolley Contacts.....	49
Trolley Contact Control Circuits.....	42-47
Upper Quadrant Flagman.....	21-35
Users of Magnetic Flagmen.....	4
Wiring Diagrams .....	42-49

\*Carried in stock but not shown in catalogue.

## FOREWORD



HE Magnetic Flagman is the adopted standard for Highway Crossing Protection on many of the largest railroad systems in the United States and abroad. The Southern Pacific, Union Pacific, Northern Pacific, Santa Fe, Chicago, Milwaukee and St. Paul, Norfolk and Western, Long Island, and scores of other roads are using this Flagman in large and ever increasing quantities.

Its design is such as to eliminate as far as possible wearing parts, and great care has been exercised to see that such few parts are fashioned so that replacement may be made at minimum expense.

The Magnetic Flagman, because of its exceptional reliability and extremely low cost of operation, stands supreme in the field of crossing protection, and its finer points are perhaps better emphasized by the following facts:

1. *Greatest Reliability.*
2. *Lowest Battery Consumption.*
3. *Extreme simplicity and ruggedness of construction—but three wearing parts.*
4. *Mechanical gong requiring no additional current.*
5. *Widest range of voltage—Direct or Alternating Current.*
6. *Lowest cost of maintenance.*

Our latest development, the Auxiliary "OUT OF ORDER" indication, providing a definite warning in event of mechanical or electrical failure, is being installed by many large railroads and receiving most favorable comment. A description of this device appears on pages 27, 28 and 29.

Flashing lights of the horizontal type may be effected in connection with the Magnetic Flagman, Gong and "OUT OF ORDER" indication, at practically no additional cost, and without Flashing Relays. Complete information upon request.

The following page will convey an idea as to the extent of the use of the Magnetic Flagman.

## List of Users of the Magnetic Flagman

- Akron, Canton & Youngstown Ry. Co.  
 Abernethy & Loughheed Logging Co.  
 (B. C., Canada)  
 Androscoggin Electric Co.  
 Ann Arbor Railroad Co.  
 Arizona Eastern Railroad Co.  
 Atchison, Topeka & Santa Fe Ry.  
 Alton Granite & St. Louis  
 Butte, Anaconda & Pacific Railway  
 British Columbia Electric Rys. (Canada)  
 Canadian National Railways (Canada)  
 Central California Traction Co.  
 Chicago, Aurora & Elgin R.R. Co.  
 Chicago, Burlington & Quincy R.R. Co.  
 Chicago, Milwaukee & St. Paul Ry. Co.  
 Chicago, North Shore & Milwaukee  
 Cincinnati, New Orleans & Texas Pacific  
 Ry. Co.  
 City of Kaukauna (Wisconsin)  
 City of Seattle (Washington)  
 Colorado & Southern  
 Comox Logging & Railway Co.  
 Coos Bay Lumber Co.  
 Copper River & Northwestern Ry. Co.  
 (Alaska)  
 County of King (Washington)  
 Clinchfield Railroad Co.  
 Delaware, Lackawanna & Western Ry. Co.  
 Denver & Rio Grande Western  
 Denver Tramways Co.  
 Detroit & Mackinac Ry. Co.  
 Duluth, Missabe & Northern Ry. Co.  
 Duluth, Winnipeg & Pacific Ry. Co.  
 East St. Louis & Suburban Ry. Co.  
 Edison Portland Cement Co.  
 El Paso & Southwestern System  
 Florida East Coast Ry. Co.  
 Fort Dodge, Des Moines & Southern Ry. Co.  
 Fresno Traction Co.  
 Galveston, Harrisburg & San Antonio Ry. Co.  
 Gary Street Railway Co.  
 Great Northern Railway Co.  
 Gulf, Colorado & Santa Fe Ry.  
 Gulf Coast Lines (See Subsidiary Roads)  
 Hawaii Consolidated Railway, Ltd. (T. H.)  
 Hershey Cuban Railway Co.  
 Hocking Valley Railway Co.  
 Houston & Texas Central Railroad  
 Houston Belt & Terminal Ry. Co.  
 Illinois Central Railway Co.  
 Inspiration Consolidated Copper Co.  
 Inter California Railway Co. (Mexico)  
 International Great Northern Ry. Co.  
 Interstate Public Service Co.  
 Italian State Railways (Italy)  
 Jamestown Westfield & Northwestern Ry. Co.  
 Kansas City Southern Ry. Co.  
 Kentucky Traction & Terminal Co.  
 Key System Transit Co.  
 Lehigh Valley Coal Co.  
 Long Island Railroad Co.  
 Los Angeles & Salt Lake Ry. Co.  
 Los Angeles Junction Railway Co.  
 Louisville & Nashville R.R. Co.  
 Louisville Railway Co. (Kentucky)  
 Midland Valley R.R. Co.  
 Milwaukee Electric Railway & Lt. Co.  
 Milwaukee Northern Railway  
 Minarets & Western Ry. Co.  
 Minneapolis & St. Paul & Sault Ste. Marie  
 Missouri Pacific R.R. Co.  
 Morgans Louisiana & Texas Railway Co.  
 Municipal Railway of San Francisco  
 Newaukum Valley Ry. Co.  
 New Cornelia Copper Co.  
 New South Wales Railways (Australia)  
 Noord Zuid Hollandshe Tramweg Maatschappig  
 (Dutch Interurban Rys., Holland)  
 Norfolk & Western Railroad  
 Northern Pacific Ry. Co.  
 Northern Texas Traction Co.  
 Northwestern Pacific Railroad Co.  
 Norwegian State Railways (Norway)  
 Oahu Railway & Land Co. (T.H.)  
 Oregon Electric Railway Co.  
 Oregon Short Line R.R. Co.  
 Oregon Washington R.R. & Nav. Co.  
 Pacific Coast Railroad  
 Pacific Electric Railway Co.  
 Pacific Northwest Traction Co.  
 Panama Railroad (Canal Zone)  
 Panhandle and Santa Fe Railway Co.  
 Peninsular Railway Co.  
 Petaluma & Santa Rosa R.R. Co.  
 Portland Railway Light & Power Co.  
 Queensland Railways (Australia)  
 Ray & Gila Valley R.R. Co.  
 Riverside Portland Cement Co.  
 St. Joseph & Grand Island Ry. Co.  
 St. Louis, Brownsville & Mexico Ry. Co.  
 St. Louis, San Francisco Ry. Co.  
 Sacramento Northern R.R.  
 San Diego and Arizona Railway Co.  
 San Diego Electric Railway Co.  
 San Francisco, Sacramento R.R. Co.  
 San Francisco Napa & Calistoga Ry. Co.  
 Simpson Logging Co.  
 Southern Pacific Co.  
 Southern Pacific Lines in Texas and  
 Louisiana  
 Southern Railways System  
 (See C.N.O. & T.P. Ry.)  
 South Australian Railways  
 Spokane Portland & Seattle Ry.  
 Stockton Electric R.R. Co.  
 Terminal Railway Assn. of St. Louis  
 Texas & New Orleans R.R. Co.  
 Texas & Pacific Railway  
 Thompson & Clark Timber Co. (Canada)  
 Union Oil Co. of California  
 Union Pacific Railroad Co.  
 Union Traction Co. of Indiana  
 United Verde Copper Co.  
 Valley & Siletz R.R. Co.  
 Ventura County Railway  
 Vicksburg Shreveport & Pacific Ry. Co.  
 Victorian Railways (Australia)  
 Visalia Electric Railway  
 Walla Walla Valley Ry. Co.  
 Wabash Railway Co.  
 Weed Lumber Co.  
 Western Pacific R.R. Co.  
 West Penn Railways Co.  
 Wheeling & Lake Erie Railway Co.



*Magnetic Flagman installed at Claremont, California, on Atchison, Topeka & Santa Fe R. R.  
More than 300 in service on this railroad.*

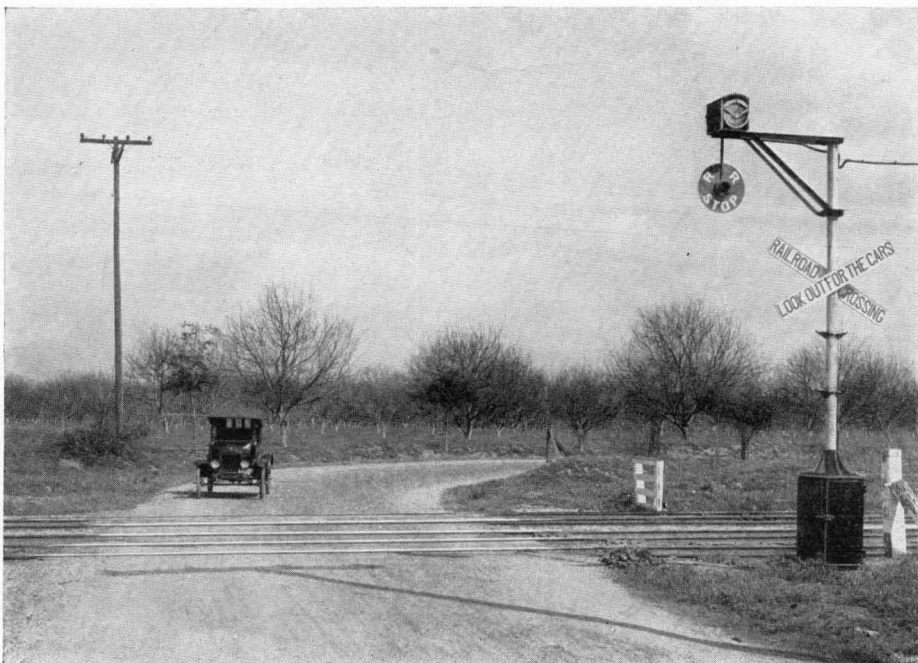

*Installation at Bassett, California, on Southern Pacific Railroad. This company  
has over 700 Magnetic Flagmen in service.*



*Installation of Magnetic Flagman (two position, lower quadrant), on the Atchison, Topeka and Santa Fe R.R. at Emporia, Kansas.*



*Installation of 8-volt D.C. Magnetic Flagman (two position, lower quadrant), on Northern Pacific R. R.*



*Installation of Magnetic Flagman (two position, lower quadrant), on Louisville & Nashville R. R., Lebanon, Ky.*



*600-volt D.C. Electric Line Installation of Magnetic Flagman (two position, lower quadrant), on Interstate Public Service Co. at Scottsburg, Indiana.*





*Installation of Magnetic Flagman (two position, lower quadrant), on Wheeling & Lake Erie R. R. at Mogadore, Ohio.*

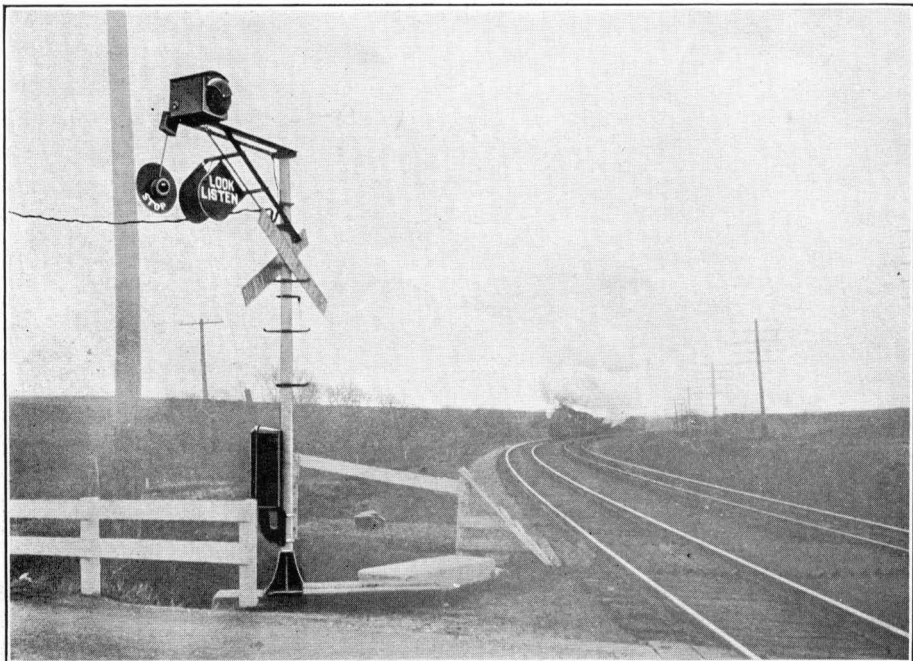

*Installation of Type LB-8 Magnetic Flagman (three position), on the Union Pacific Railroad Company, near Omaha, Nebraska. Many hundred Magnetic Flagmen in operation on this system.*



*Installation of Magnetic Flagman (two position, lower quadrant), on the Copper River & Northwestern Railway at Cordova, Alaska.*



*Installation of Magnetic Flagman (two position, lower quadrant), on Victorian Railways, at Melbourne, Australia.*



*Center of Street Installation of Magnetic Flagman (two position, upper quadrant, with "Out-of-Order" attachment), on the Kansas City Southern Railway.*



*Center of Street Installation of Type LB-8 Magnetic Flagman (three position),  
on Union Pacific R. R. at Anaheim, California.*



*Center of Street Installation of Magnetic Flagman (two position, upper quadrant),  
on Missouri Pacific Railroad at Neodesha, Kansas.*

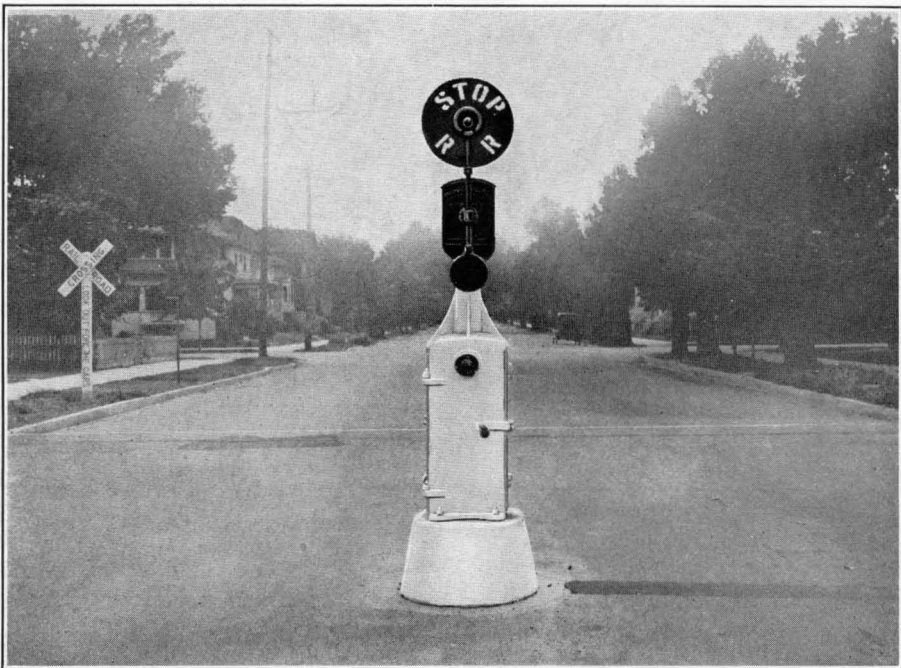

*Center of Street Installation of Magnetic Flagman (two position, upper quadrant),  
on the Western Pacific Railroad, Sacramento, California.*

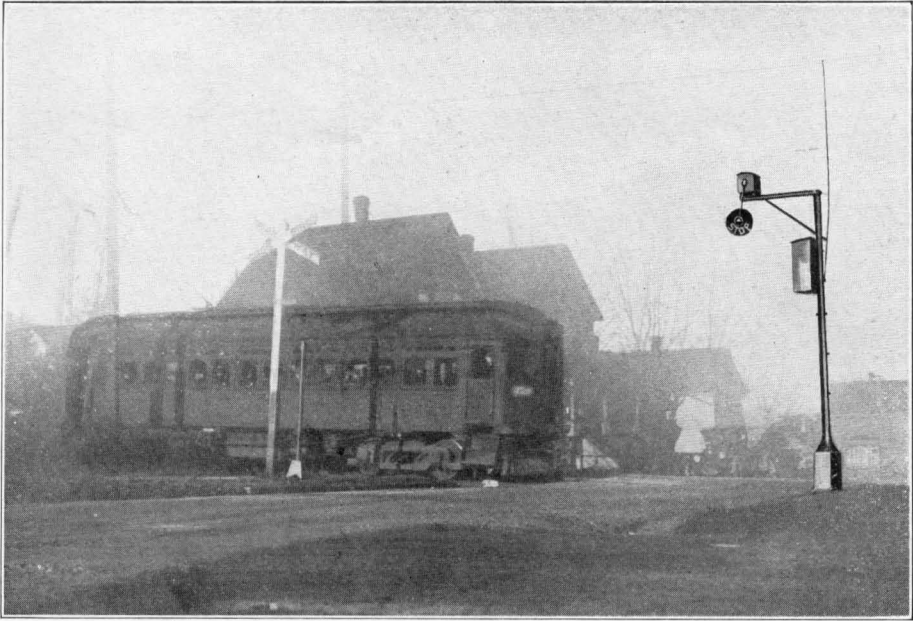

*600-volt D.C. Electric Line Installation (two position, lower quadrant), on British Columbia Electric Railway, Vancouver, B. C.*

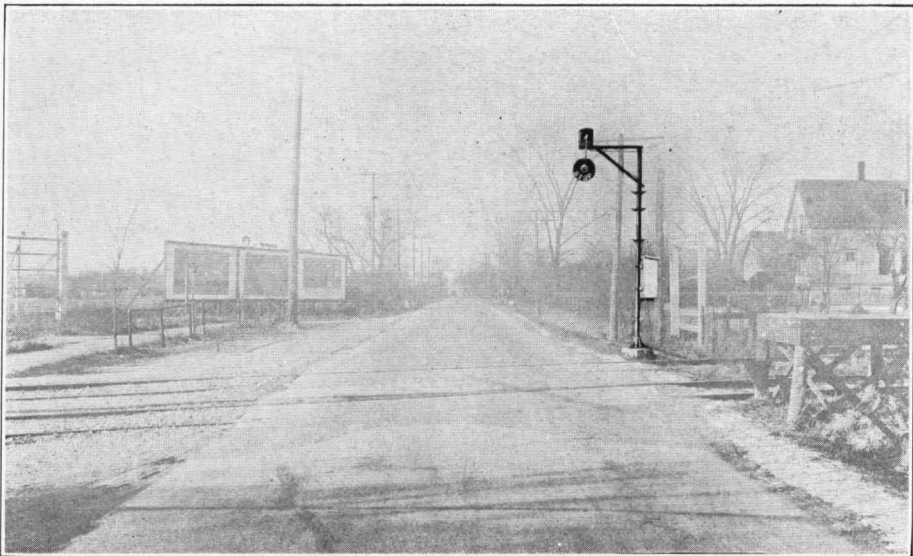

*600-volt D.C. Electric Line Installation of Magnetic Flagman (two position, lower quadrant), on Milwaukee Northern Railroad, Silver Spring Road Crossing.*



*Two Position Magnetic Flagman together with "Out-of-Order" Auxiliary Signals in operation on the Long Island Railroad. Illustration shows Signal in normal operating position with "Out of Order" Banner concealed.*



*Illustrating same installation with "Out-of-Order" Banner dropped, indicating failure to operate from either electrical or mechanical causes.*

The Pacific Electric Railway was first to employ a Wig-Wag Signal for the protection of its crossings, and after several years use of the motor-driven type, the Magnetic Flagman was placed in service, and shortly thereafter adopted as standard.



*Double installation of 600-volt D. C. Magnetic Flagman, using power from trolley line, on Pacific Electric Railway four-track system at Huntington Boulevard, Los Angeles. Operation controlled by Trolley Brush Contacts, and Simplex Relays. There are over 1200 interurban train movements at this crossing per day. This railway has installed over 500 of our Magnetic Flagmen.*

In 1920, after several years of efficient and economical operation, the Magnetic Flagman replaced 117 motor-driven wig-wags which were ordered scrapped, and Pacific Electric officials estimate a resulting saving in maintenance alone of approximately \$6000.00 per annum.



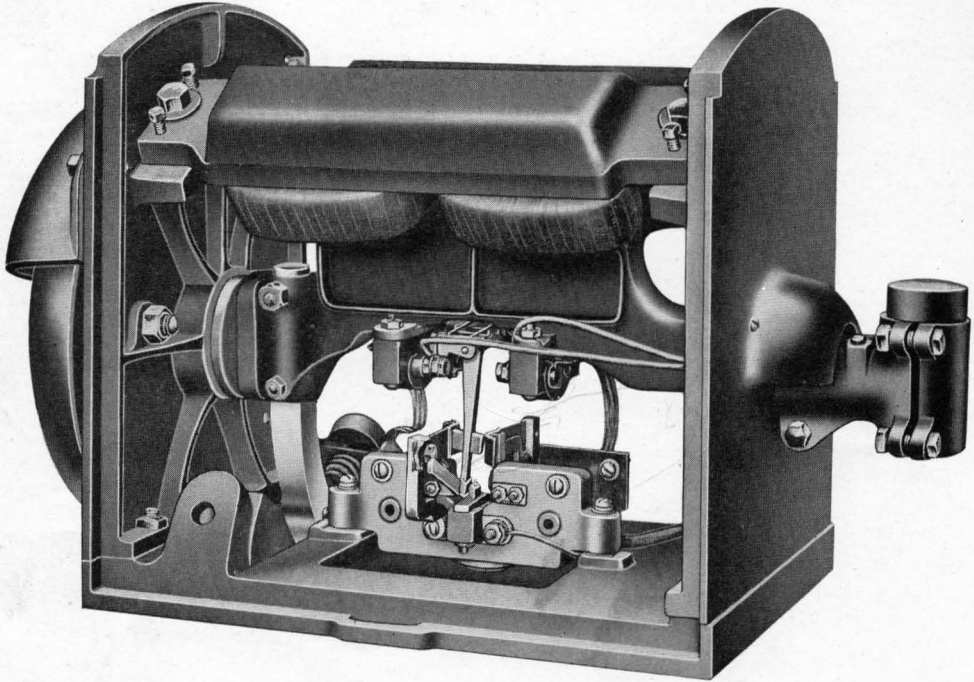

*Side view of Magnetic Flagman Mechanism, with top, doors and flag removed, illustrating contact circuit breaker used on all types of flagmen.*

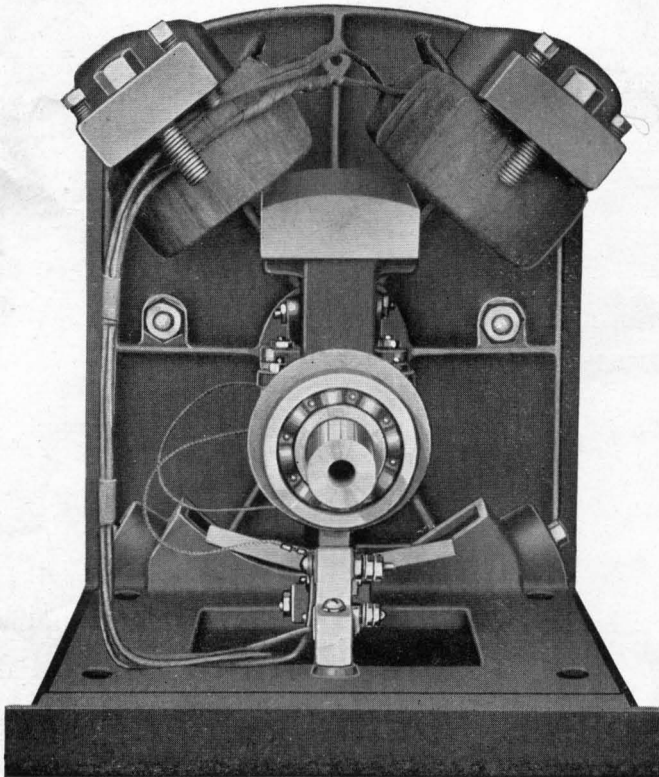

*End view showing operating mechanism with end plate, top, doors and flag removed.*

Note the simple and rugged construction of the Magnetic Flagman. The swinging armature shaft is carried in annular ball bearings, thus practically eliminating friction, and permitting great ease of movement to the oppositely arranged magnets. The mechanism is entirely fool-proof.

Above cuts illustrate the accessibility of signal for inspection and maintenance purposes, allowing quick and easy adjustment and renewal of parts without removing machine from service.

## Standard 8-Volt Magnetic Flagman

The construction of the Magnetic Flagman is of such simplicity and ruggedness as to make it practically immune from trouble and the resulting expense. The mechanism is well housed in a weather-proof cast iron case with felted metal doors, thus eliminating complications caused by snow, ice, or sand.

The mechanism itself requires only the regular inspection required by any electrical or mechanical device. There are but three wearing parts—the contact finger and two stationary contact guides, which parts in normal service should not require replacing for two to three years, and then at a very nominal labor and material cost. In making repairs or replacements it is not necessary to remove the mechanism from the pole, as all such repairs may be made on the pole by the maintainer in a few minutes' time.

The Magnetic Flagman is built to "stand up." All parts are oversize—tested for strength—and after assembly, before shipment, each machine is subjected to a rigorous test.

*Practically all steam road Magnetic Flagmen operate on twelve 500 ampere hour rectangular primary cells, and it is definitely proven that the battery life with Magnetic operation is from three to five times that with motor operation. The initial impulse of current required for starting the machine is 2.5 amperes at 8 volts, and impulses required thereafter are 1.5 amperes. Therefore, because of the relatively short time of contact, .78 ampere is the average required to operate the Flagman together with its gong and 5 watt light. The 8-volt Magnetic Flagman will operate from 5½ to 12 volts equally well—thus allowing for wide voltage variation.*

The flag oscillates rapidly, approximately 100 times per minute, moving thru an arc of 70 degrees, the gong striking at the same time. This gives a far better warning than the slower, shorter-moving motor type.

*When shipment is made each Magnetic Flagman is mechanically and electrically a high-grade instrument and will perform its service in a highly satisfactory manner. Any machine failing to do so will be replaced free of any charges whatsoever. This is our absolute guarantee.*

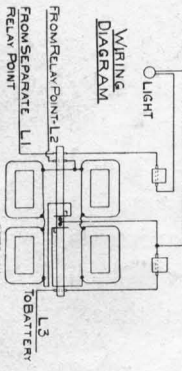
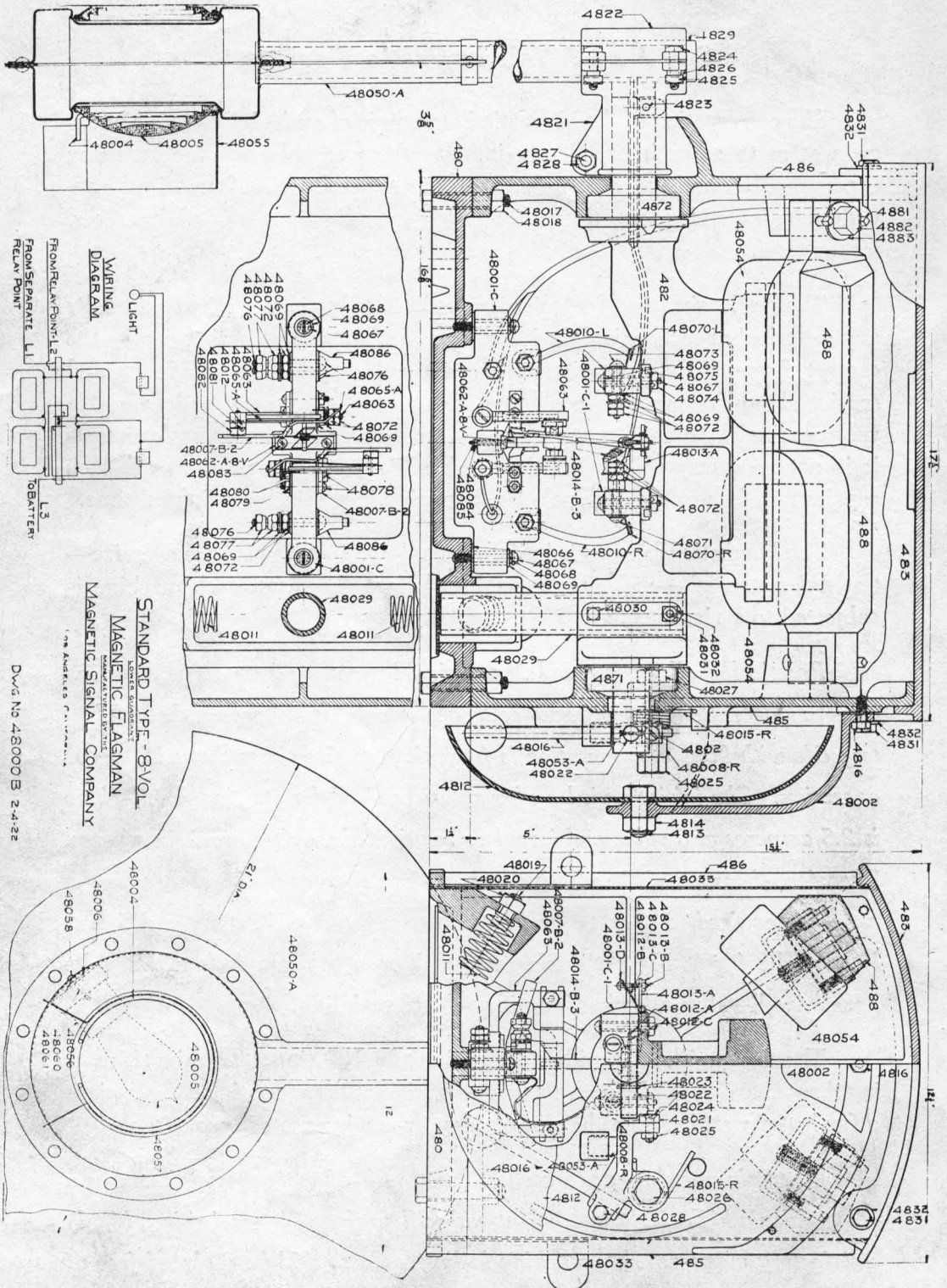

STANDARD TYPE - 8VOLT  
 MAGNETIC FLAGMAN  
 MAGNETIC SIGNAL COMPANY  
 1740 ANDREWS STREET, LOS ANGELES, CALIF.

DWG No 48000 B 2-4-22

Type JH-8 Magnetic Wigwag Flagman Mechanism (For 8-volt direct current operation, no brake, two position with bell)

## Parts for Type JH-8 (8-Volt D. C.) Magnetic Flagman

Additional parts for Type KC-8 (8-volt D.C. Brake) on page 22.

### Drawing No. 48000-B

NUMBER	NAME	NUMBER	NAME
480	Base C. I.	48016	Bell Striker
482	Armature C. I.	48017	Connecting Bolt (Base)
483	Top Cover C. I.	48018	Connecting Nut (Base)
485	Bell End C. I.	48019	Bolt (Buffer Spring)
486	Hood End C. I.	48020	Nut (Buffer Spring)
488	Magnet C. I.	48021	Striker Lug
4812	Bell	<del>48022</del>	<del>Striker Lug Tripper</del>
4813	Bolt (Bell Cover and Support)	48023	Cotter Key (Tripper)
4814	Nut (Bell Cover and Support)	48024	Screw (Striker Lug)
4816	Cap Screw (Bell Cover and Support)	48025	Nut (Striker Lug)
4821	Flag Holder	48026	Bolt (Striker Hub)
4822	Flag Holder Clamp	48027	Nut (Striker Hub)
4823	Flag Holder Pin	48028	Cap Screw (Striker Hub)
4824	Bolt (Flag Holder)	48029	Buffer
4825	Nut (Flag Holder)	48030	Set Screw (Buffer)
4826	Lock Washer (Flag Holder)	48031	Bolt (Buffer)
4827	Clamp Bolt (Flag Holder)	48032	Nut (Buffer)
4828	Lock Nut (Flag Holder)	48033	Door
4829	Pipe Cap	48050	Standard Flag Complete (Lower Quadrant), (including lenses, wiring and light shades)
4831	Cap Screw (Top Cover)	48150	Flag only, Lower Quadrant (without wiring or fixtures)
4832	Washer (Top Cover)	X-48050	Flag Complete with Fixtures (For 2-light machines) Lower Quadrant
4871	Ball Bearing (Bell End)	48053-A	Rubber Buffer (Bell Striker) 1/2" Round
4872	Ball Bearing (Flag End)	48054	Magnet Coil—8-volt D. C.
4881	Set Screw (Magnet)	48055	Light Shield
4882	Cap Screw (Magnet)	48155	Light Shield—Hinged Type
4883	Washer (Magnet)	48056	Light Receptacle
480010	Porcelain Terminal Board Assembly—Long Diamond (including all Lower Contact Parts)	48057	2 1/2 watt Mazda Lamp Edison Base
48001-C	Porcelain Terminal Board	48057-A	5 watt Mazda Lamp Edison Base
48001-C-1	Porcelain Bracket Support	48058	Screw (Light Receptacle Support)
48002	Bell Cover	48060	Screw (Light Receptacle)
48004	Retainer Spring (Lens)	48061	Nut (Light Receptacle)
48005	Lens	<del>48062-A-8-V</del>	<del>Contact Guide—Long</del>
48006	Support (Light Receptacle)	48063	Bracket (Stationary Contact)
X-48006	Support (Light Receptacle) (For 2-light flag)	48065-A	Stationary Contact
48007-B-2	Stop (Movable Finger)	48066	Lead Washer (Terminal Board Support)
48008-R	Striker Hub, Right	48067	Screw
48008-L	Striker Hub, Left	48068	Lock Washer (Terminal Board Support)
48010-R	Flexible Connection, Right	48069	Brass Washer (Terminal Board Support)
48010-L	Flexible Connection, Left	48071	Screw (Bracket)
X-48010	Extra Flexible Connection (For 2-light Flag)	48072	Nut (Bracket)
48011	Flag Buffer Spring	48073	Screw (Light Terminal)
48012	Clamp Block (Stationary Contact)	48074	Nut (Armature Insulation)
48012-A	Pin (Movable Finger Contact)	48075	Copper Lock
48012-B	Spring (Movable Finger Contact)	48076	Screw (Binding Post)
48012-C	Cotter Key (Movable Finger Contact)	48077	Nut (Binding Post)
48013-A	Bracket (Movable Finger Contact)	48078	Screw (Finger Stop)
48013-B	Screw (Movable Finger Contact)	48079	Copper Lock (Finger Stop)
48013-C	Nut (Movable Finger Contact)	48080	Nut (Finger Stop)
48013-D	Washer (Movable Finger Contact)	48081	Copper Lock (Stationary Contact)
480140	Movable Finger Contact Assembly (including Mov. Finger, Bracket Spring and Pin)	48082	Cap Screw (Stationary Contact)
48014-B-3	Movable Finger Contact	48083	Screw (Contact Guide)
48015-R	Bell Ringer Spring, Right	48084	Copper Lock (Contact Guide)
48015-L	Bell Ringer Spring, Left	48085	Nut (Contact Guide)

**Drawing No. JH-26. Contact Parts for Magnetic Flagman.**

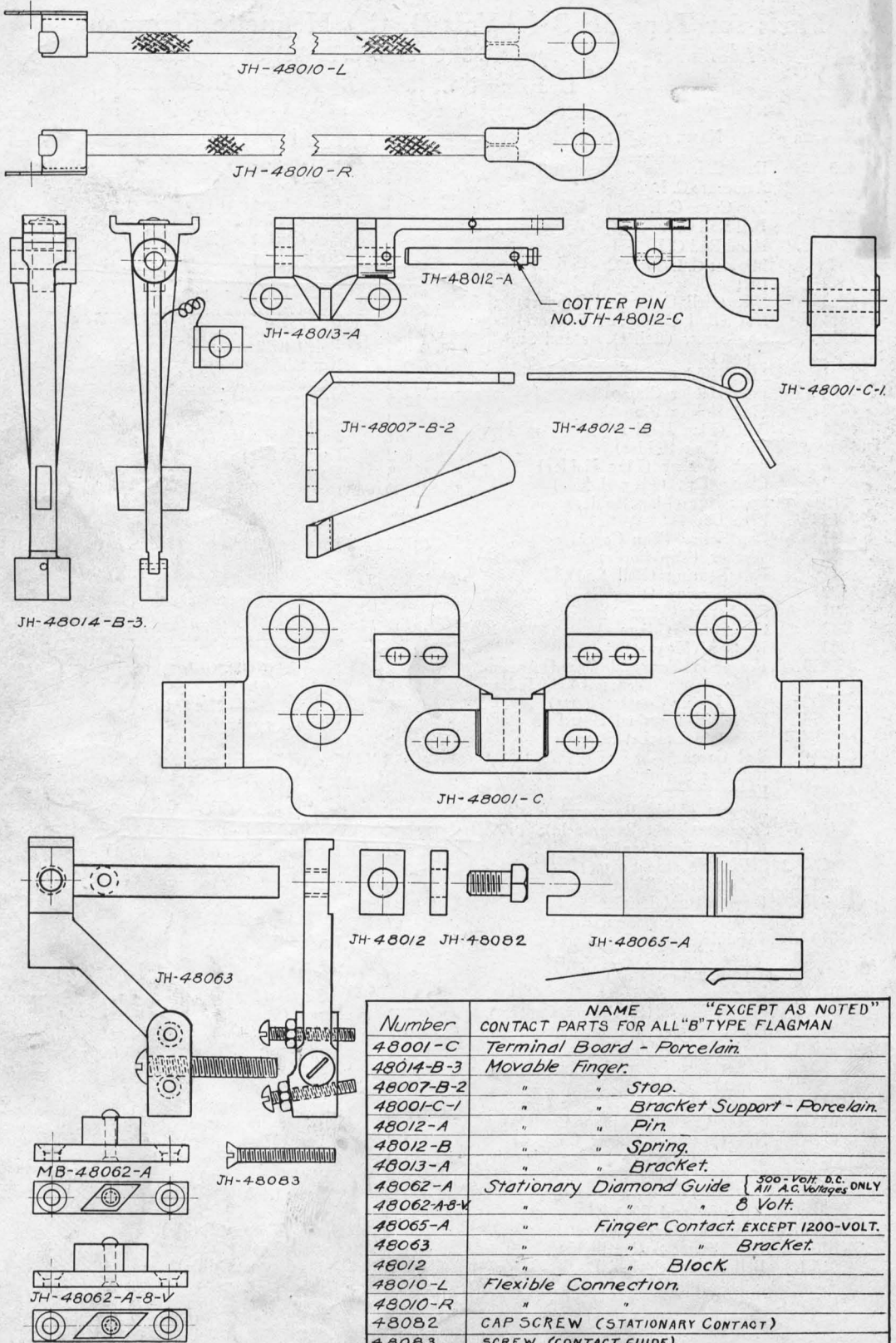

Number	NAME "EXCEPT AS NOTED"
48001-C	Terminal Board - Porcelain.
48014-B-3	Movable Finger.
48007-B-2	" " Stop.
48001-C-1	" " Bracket Support - Porcelain.
48012-A	" " Pin.
48012-B	" " Spring.
48013-A	" " Bracket.
48062-A	Stationary Diamond Guide <small>500-Volt D.C. All A.C. Voltages ONLY</small>
48062-A-8-V	" " 8 Volt.
48065-A	" Finger Contact. EXCEPT 1200-VOLT.
48063	" " Bracket.
48012	" " Block.
48010-L	Flexible Connection.
48010-R	" "
48082	CAP SCREW (STATIONARY CONTACT)
48083	SCREW (CONTACT GUIDE)

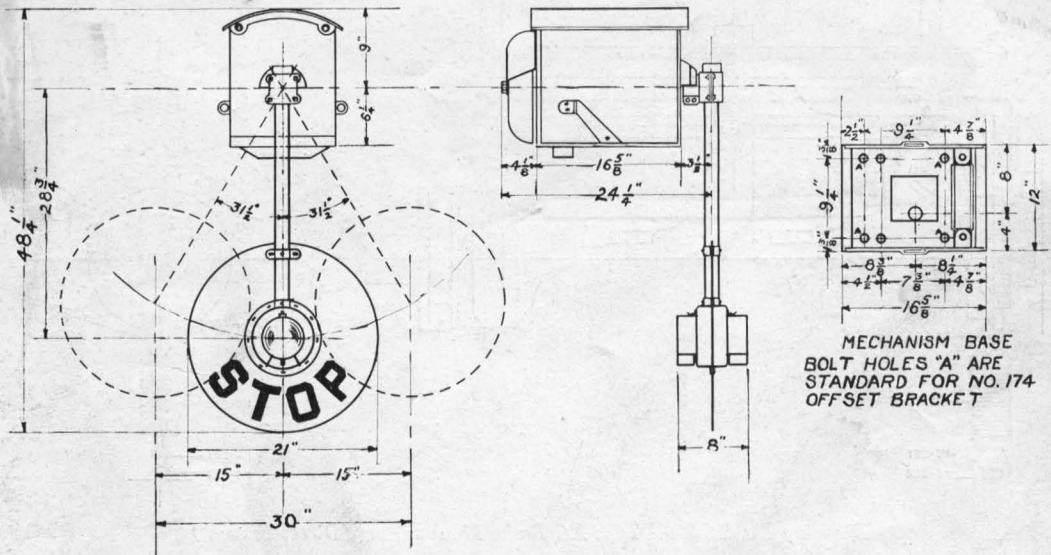

Drawing No. JH-100. Standard Two Position Magnetic Flagman, Lower Quadrant, with Bell.

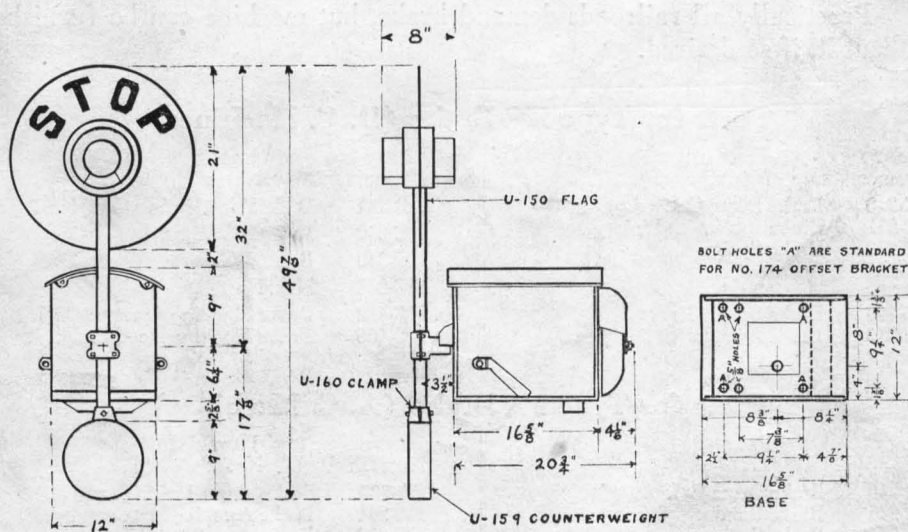

Drawing No. U-100. Type "U" Two Position Magnetic Flagman, Upper Quadrant, with Bell.

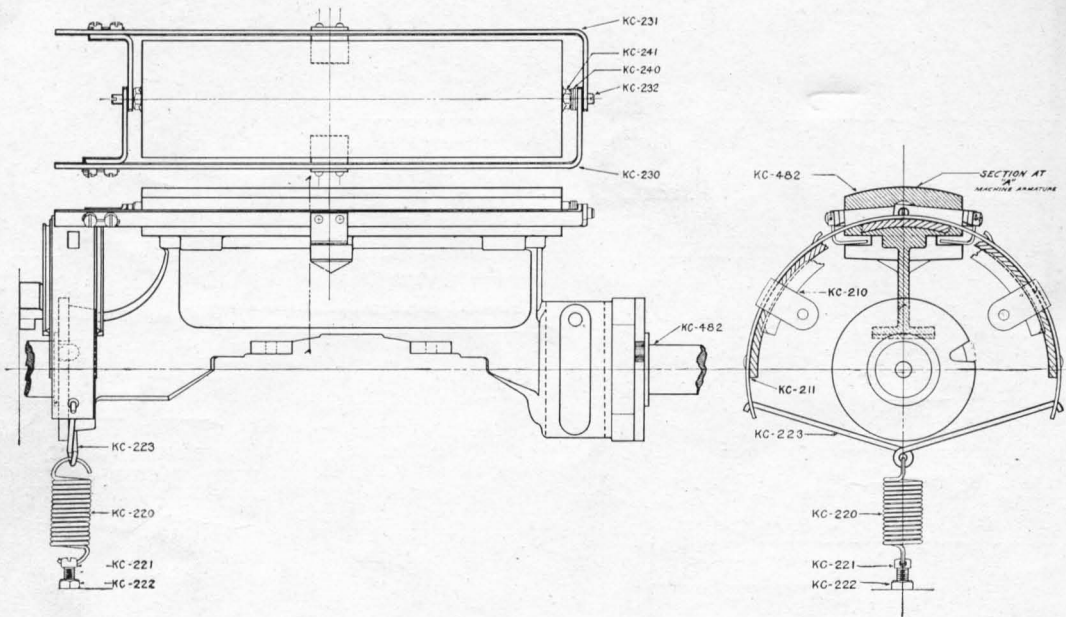

Drawing No. KC-200. Type KC Brake Mechanism. (Direct Current)

### Brake Attachment

Unless otherwise specified all two position machines are equipped with brake. The brake is substantial and positive, and serves not only to hold the flag in contact in the event of excessive wind, but to bring it to a quick stop upon train clearing block.

Practically all railroads demand brake, but machine can be furnished without it, if so desired.

#### Parts for Type KC Brake (D. C. Machines)

PART NUMBER	PART NAME	PART NUMBER	PART NAME
KC-210	Brake Drum C. I.	KC-231	Brake Arm, Right (Complete)
KC-211	Brake Band with Lining	KC-232	Brake Arm Pins
KC-220	Brake Spring	KC-240	Brass Washers
KC-221	Spring Screw	KC-241	Hex. Nuts
KC-222	Hex. Nut	KC-482	Brake Machine Armature C. I.
KC-223	Brake Spring Bar	KC-486	Brake Machine Hood End C. I.
KC-230	Brake Arm, Left (Complete)		

#### Parts for Type PA Brake (A. C. Machines)

PART NUMBER	PART NAME	PART NUMBER	PART NAME
PA-210	Brake Drum C. I.	PA-230	Brake Arm, Left (Complete)
PA-211	Brake Band with Lining	PA-231	Brake Arm, Right (Complete)
PA-220	Brake Spring	KC-232	Brake Arm Pins
PA-221	Spring Screw	PA-230	Brass Washers
PA-222	Hex. Nut	PA-241	Hex. Nuts
PA-223	Brake Spring Bar	PA-482	A. C. Brake Machine Armature C. I.

## Standard A. C. Magnetic Flagman

Because of the small starting torque when using alternating current it has been a problem to develop a device of any nature that would operate in a thoroughly reliable manner, but we have, however, developed an alternating current Magnetic Flagman of unqualified success. This has been accomplished through the use of an additional mechanism termed a coil cut-out.

*By use of the coil cut-out, the flag will pull over on 75 volts—110-volt circuit—and operate on considerably less than that.* After the flag has attained its normal speed one set of coils automatically cuts out and remains out unless there should be a drop in voltage, in which event it will again cut in.

The Southern Pacific, Chicago, Milwaukee & St. Paul, and Norfolk & Western have installed many A.C. Magnetic Flagmen equipped with coil cut-out, and officials in charge of these operations are highly pleased with the results they are obtaining.

### A. C. Magnetic Flagmen are Furnished in the Following Types

*In ordering be sure to specify correct type number as shown below.*

TYPE NO.	NAME	APPROX. DOMESTIC SHIPPING WEIGHT—POUNDS
MB-55-25	Magnetic Wigwag Flagman Mechanism..... (Above for 55 volts, alternating current, 25 cycle operation, no brake, two position with bell and coil cut-out)	260
MB-55-60	Magnetic Wigwag Flagman Mechanism..... (Above for 55 volts, alternating current, 50 or 60 cycle operation, no brake, two position, with bell and coil cut-out)	260
MB-110-25	Magnetic Wigwag Flagman Mechanism..... (Above for 110 volts alternating current, 25 cycle operation, no brake, two position, with bell and coil cut-out)	260
MB-110-60	Magnetic Wigwag Flagman Mechanism..... (Above for 110 volts, alternating current, 50 or 60 cycle operation, no brake, two position, with bell and coil cut-out)	260
MB-220-25	Magnetic Wigwag Flagman Mechanism..... (Above for 220 volts, alternating current, 25 cycle operation, no brake, two position, with bell and coil cut-out)	260
MB-220-60	Magnetic Wigwag Flagman Mechanism..... (Above for 220 volts, alternating current, 50 or 60 cycle operation, no brake, two position, with bell and coil cut-out)	265
PA-55-25	Magnetic Wigwag Flagman Mechanism..... (Above for 55 volts, alternating current, 25 cycle operation, with brake, two position, with bell and coil cut-out)	265
PA-55-60	Magnetic Wigwag Flagman Mechanism..... (Above for 55 volts, alternating current, 50 or 60 cycle operation, with brake, two position with bell and coil cut-out)	265
PA-110-25	Magnetic Wigwag Flagman Mechanism..... (Above for 110 volts, alternating current, 25 cycle operation, with brake, two position, with bell and coil cut-out)	265
PA-110 60	Magnetic Wigwag Flagman Mechanism..... (Above for 110 volts, alternating current, 50 or 60 cycle operation with brake, two position, with bell and coil cut-out)	265
PA-220-25	Magnetic Wigwag Flagman Mechanism..... (Above for 220 volts, alternating current, 25 cycle operation, with brake, two position, with bell and coil cut-out)	265
PA-220 60	Magnetic Wigwag Flagman Mechanism..... (Above for 220 volts, alternating current, 50 or 60 cycle operation, with brake, two position, with bell and coil cut-out)	265

NOTE: *Above reference numbers are for Lower Quadrant Flagmen only.  
In case Upper Quadrant Flagman add prefix "U" to type number.*



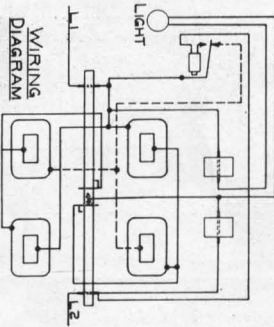
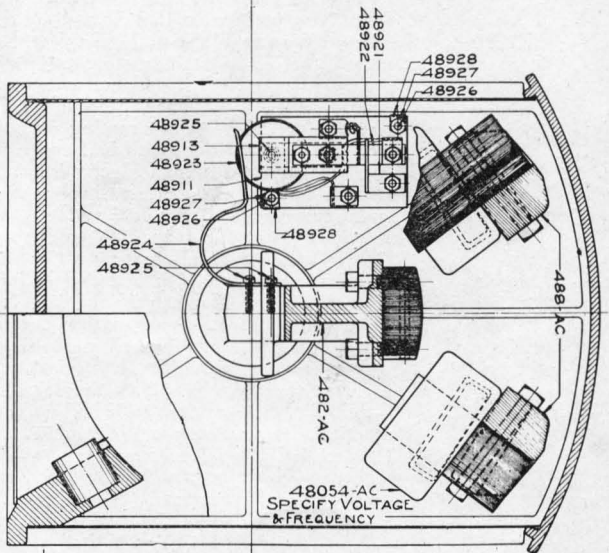
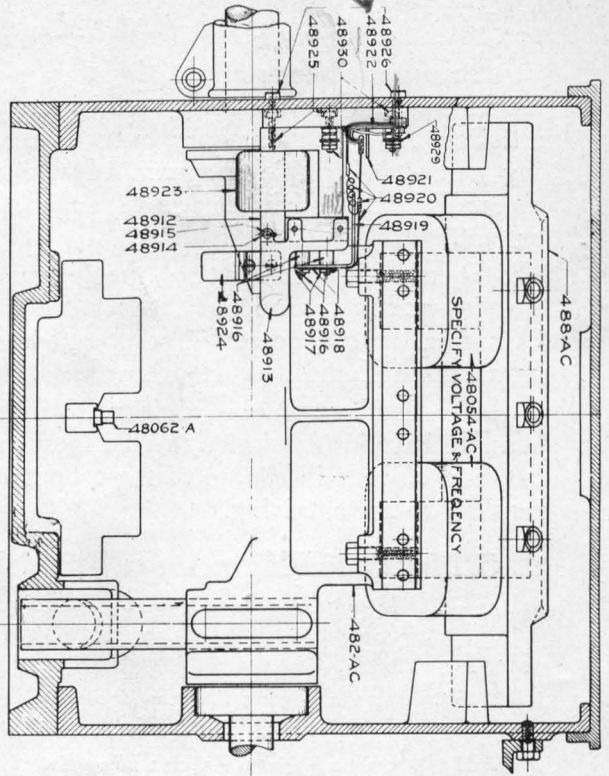
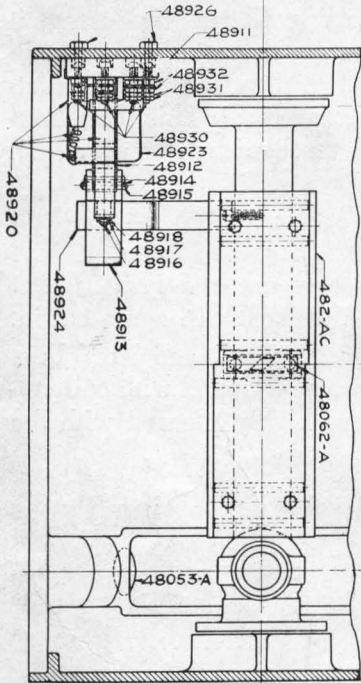

STANDARD TYPE -A-C  
MAGNETIC FLAGMAN  
MAGNETIC SIGNAL COMPANY

Los Angeles, California

Scale - Full Size

Dwg No 48000 B-1 2-18-22

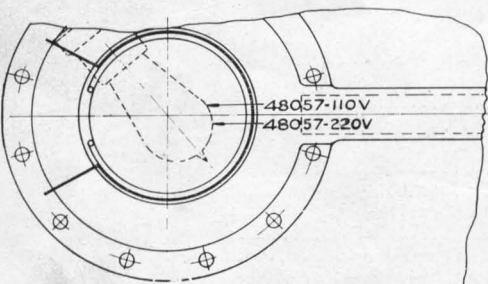

Type MB (Alternating Current) Magnetic Flagman

ALL OTHER PARTS ARE IDENTICAL WITH PARTS FOR STANDARD TYPE B VOLT FLAGMAN.

## Parts for Alternating Current Magnetic Flagman Drawing No. 48000-B-1.

In ordering parts give name and part number, as well as type, voltage, and frequency of Flagman to which part is to be applied. Advise whether Flagman has upper or lower quadrant flag.

Type MB Lower Quadrant Flag—No Brake    Type PA Lower Quadrant Flag—With Brake  
Type UMB Upper Quadrant Flag—No Brake    Type UPA Upper Quadrant Flag—With Brake

Parts listed below are interchangeable on alternating current Magnetic Flagmen equipped with or without brake.

For brake parts see Page 22.

Other parts not listed below or on Page 22 are identical with JH-8 (8-volt D. C. Flagman), shown on Pages 18 and 19.

NUMBER	NAME	NUMBER	NAME	NUMBER	NAME
MB-482	Laminated Armature	MB-48054-110-60	Field Coils—Starting (For Lower Quadrant Mechanisms only) 110-volt 50 or 60 cycle A.C. operation, also for 55-volt 25 cycle A.C. operation. Above coils are cut out after machine is in full operation	MB-48054-220-25	Field Coils—Starting (For Lower Quadrant Mechanisms only) 220-volt 25 cycle A.C. operation. Above coils are cut out after machine is in full operation
MB-485	Bell End Casting	MB-48154-110-60	Field Coils—Operating (For Lower Quadrant Mechanisms only) 110-volt 50 or 60 cycle A.C. operation, also for 55-volt 25 cycle A.C. operation. Above coils are energized continuously while machine is in operation	MB-48154-220-25	Field Coils—Operating (For Lower Quadrant Mechanisms only) 220-volt 25 cycle A.C. operation. Above coils are energized continuously while machine is in operation
MB-488	Laminated Magnet	UMB-48054-110-25	Field Coils—Starting (For Upper Quadrant Mechanisms only) 110-volt 25 cycle A.C. operation, also for 220-volt 50 or 60 cycle A.C. operation. All coils on above operation are identical	UMB-48054-220-25	Field Coils—Starting (For Upper Quadrant Mechanisms only) 220-volt 25 cycle A.C. operation. Above coils are cut out after machine is in full operation
MB-486010	Porcelain Terminal Board Assembly (including lower contact parts and short diamond No. 48062-A as shown on drawing)	UMB-48054-110-60	Field Coils—Operating (For Upper Quadrant Mechanisms only) 110-volt 50 or 60 cycle A.C. operation, also for 55-volt 25 cycle A.C. operation. Above coils are energized continuously while machine is in operation	UMB-48154-220-25	Field Coils—Operating (For Upper Quadrant Mechanisms only) 220-volt 25 cycle A.C. operation. Above coils are energized continuously while machine is in operation
MB-48011-A	Rubber Flag Buffer	UMB-48054-110-25	Field Coils—Starting (For Upper Quadrant Mechanisms only) 110-volt 25 cycle A.C. operation, also for 220-volt 50 or 60 cycle A.C. operation. Above coils are cut out after machine is in full operation	MB-48057-110V	Mazda Lamp 110-volt 25 watt Mill Type Edison Base
MB-48054-110-25	Field Coils (For Lower Quadrant Mechanisms only) 110-volt 25 cycle A.C. operation, also for 220-volt 50 or 60 cycle A.C. operation. All coils on above operation are identical	UMB-48154-110-25	Field Coils—Operating (For Upper Quadrant Mechanisms only) 110-volt 50 or 60 cycle A.C. operation, also for 55-volt 25 cycle A.C. operation. Above coils are energized continuously while machine is in operation	MB-48062-A	Contact Guide—Short
MB-48054-110-60	Field Coils—Starting (For Upper Quadrant Mechanisms only) 110-volt 25 cycle A.C. operation, also for 220-volt 50 or 60 cycle A.C. operation. Above coils are energized continuously while machine is in operation	UMB-48154-110-60	Field Coils—Operating (For Upper Quadrant Mechanisms only) 110-volt 50 or 60 cycle A.C. operation, also for 55-volt 25 cycle A.C. operation. Above coils are energized continuously while machine is in operation	MB-48189	Field Coil Support (For supporting A.C. Coils to laminated magnet)
MB-48054-110-25	Field Coils—Starting (For Upper Quadrant Mechanisms only) 110-volt 25 cycle A.C. operation, also for 220-volt 50 or 60 cycle A.C. operation. Above coils are energized continuously while machine is in operation				
MB-48054-110-60	Field Coils—Operating (For Upper Quadrant Mechanisms only) 110-volt 50 or 60 cycle A.C. operation, also for 55-volt 25 cycle A.C. operation. Above coils are energized continuously while machine is in operation				

## Coil Cut-Out Parts for All Types A. C. Flagmen

NUMBER	NAME	NUMBER	NAME	NUMBER	NAME
MB-489-55-25	Coil Cut-Out Mechanism Complete (For 55-volt 25 cycle A.C. operation only)	MB-48917	Hex. Nuts (For Ins. Studs)	MB-48925	Fil. Head Machine Screw $\frac{5}{8}$ " x 10/32 (For Magnet Core)
MB-489-110-25	Coil Cut-Out Mechanism Complete (For 110-volt 25 cycle A.C. operation only)	MB-48918	Copper Lock Washer (Stud Nuts)	MB-48926	Screws (See MB-48952)
MB-489-110-60	Coil Cut-Out Mechanism Complete (For 110-volt 50 or 60 cycle A.C. operation only)	MB-48919	Contact Stop	MB-48927	Hex. Nuts (Main Support Screws)
MB-489-220-25	Coil Cut-Out Mechanism Complete (For 220-volt 25 cycle operation only)	MB-48920	Contact Finger Complete	MB-48928	Copper Lock Washer
MB-489-220-60	Coil Cut-Out Mechanism Complete (For 220-volt 60 cycle A.C. operation only)	MB-48921	Contact Pole—Upper	MB-48929	Washer (For Binding Post)
MB-48911	Insulating Base	MB-48922	Contact Pole—Lower	MB-48930	Binding Posts—Round Head Machine Screws, $\frac{7}{8}$ " x 10/32
MB-48912	Laminated Magnet Core	MB-48923-55-25	Cut-Out Magnet Coil (For 55-volt 25 cycle A.C. operation only)	MB-48931	Thin Hex. Nuts for Binding Posts
MB-48913	Laminated Armature complete with casting	MB-48923-110-25	Cut-Out Magnet Coil (For 110-volt 25 cycle A.C. operation only)	MB-48932	Thick Hex. Nuts for Binding Posts
MB-48914	Cotter $\frac{1}{8}$ " x $\frac{5}{8}$ "	MB-48923-110-60	Cut-Out Magnet Coil (For 110-volt 50 or 60 cycle A.C. operation only)	MB-48940	Lead Wires with Terminals 12 $\frac{1}{2}$ " long
MB-48915	Armature Pin	MB-48923-220-25	Cut-Out Magnet Coil (For 220-volt 25-cycle A.C. operation only)	MB-48941	Lead Wires with Terminals 19" long
MB-48916	Insulating Studs	MB-48923-220-60	Cut-Out Magnet Coil (For 220-volt 60 cycle A.C. operation only)	MB-48951	Mounting Tube for Coil Cut-Out
		MB-48924	Contact Closing Lever	MB-48952	Round Head Iron Machine Screw 2" x 10/32 (For mounting Coil Cut-Out)
		MA-48924	Contact Closing Lever — Obsolete Type		

## Type JH-600 Standard 600-Volt Magnetic Flagman

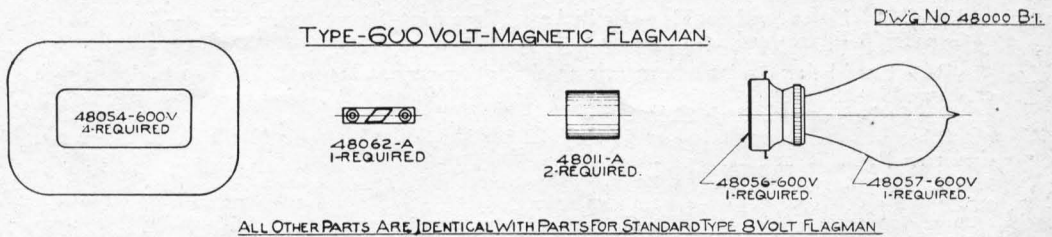

*Drawing 48000 B1*

NUMBER	NAME	NUMBER	NAME
48054-600 V	Coil	48057-600 V	Mazda Edison Base Lamp 110V 25W Mill Type
48062-A	Contact Guide—Short	48157-600 V	Carbon Lamp 220V 16 C.P. Edison Base
48011-A	Rubber Buffer	48165	Stationary Contact for 1200 V.
48056-600 V	Lamp Receptacle	48354	Coil-Insulated for 1200 V.

The 600-volt Magnetic Flagman is standard on many electric and interurban lines, its operation being controlled by trolley or track contacts and Simplex Relays. Its performance is similar in every respect to the 8-volt, and its construction identical, with the exception of the coil winding and a few slightly different parts—illustrated above.

### 1200-Volt Direct Current Magnetic Flagman

We do not furnish a special machine for above purpose; however, our 600-volt machine with resistance to reduce voltage to 600 makes a very reliable installation. Such resistance should be 4200 ohms with continuous current capacity of 140 mil-amps. Contact opening between movable finger contact and stationary contact upon breaking should be adjusted to not less than  $\frac{5}{16}$ " to prevent drawing of arc.

### Proper Reference for Ordering Two Position Lower Quadrant 600-Volt Flagman

NUMBER	NAME	SHIPPING Wt.
JH-600	Magnetic Wigwag Flagman Mechanism (Above for 600-volt direct current operation, no brake, including bell.)	260 lbs.
KC-600	Magnetic Wigwag Flagman Mechanism (Above for 600-volt direct current operation, with brake, including bell.)	265 lbs.

## "Out of Order" Signal

The "Out of Order" Signal is our most recent contribution to the field of adequate crossing protection. It affords the maximum warning to the motorist and the safest insurance to the railroad.

It has been designed and developed to operate in conjunction with the Magnetic Flagman, and will definitely indicate when the Flagman is inoperative. The construction is simple, action positive, and cost reasonable.



*Magnetic Flagman together with "Out of Order" signal in normal operating position.*



*Magnetic Flagman together with "Out of Order" signal indicating either mechanical or electrical failure.*

The "Out of Order" blade, red with white letters, is normally suspended under a metallic hood. Should the Flagman become inoperative from failure of electric energy, or from any mechanical cause, after a period of approximately three seconds this blade will drop to a conspicuous position immediately below the flagman banner.

You can procure no better crossing protection than that provided by the combination of Magnetic Flagman and "Out of Order." It is the only device on the market rendering this important service.

"Out of Order" may be specified with new Magnetic Flagman installations or may be installed at present locations with no mechanical change to the Flagman. See wiring diagrams on Page 44.

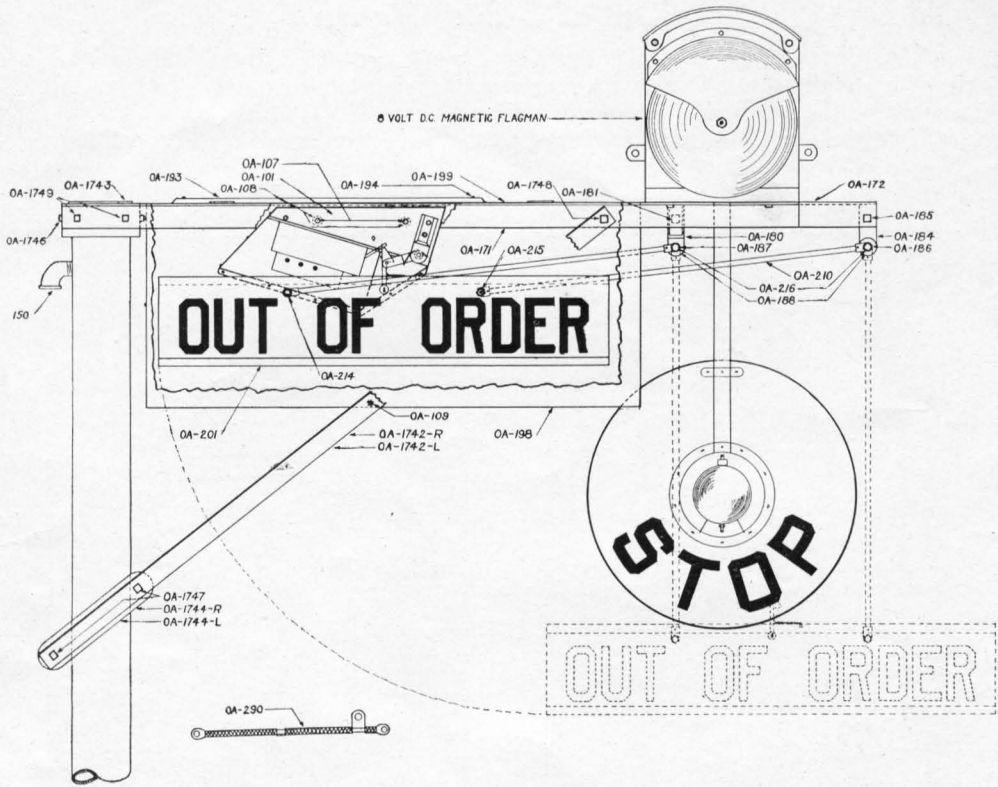

Drawing No. OA-100. Assembly Type KC-8 Magnetic Flagman with Type OA-8 Auxiliary "Out-of-Order" Signal.

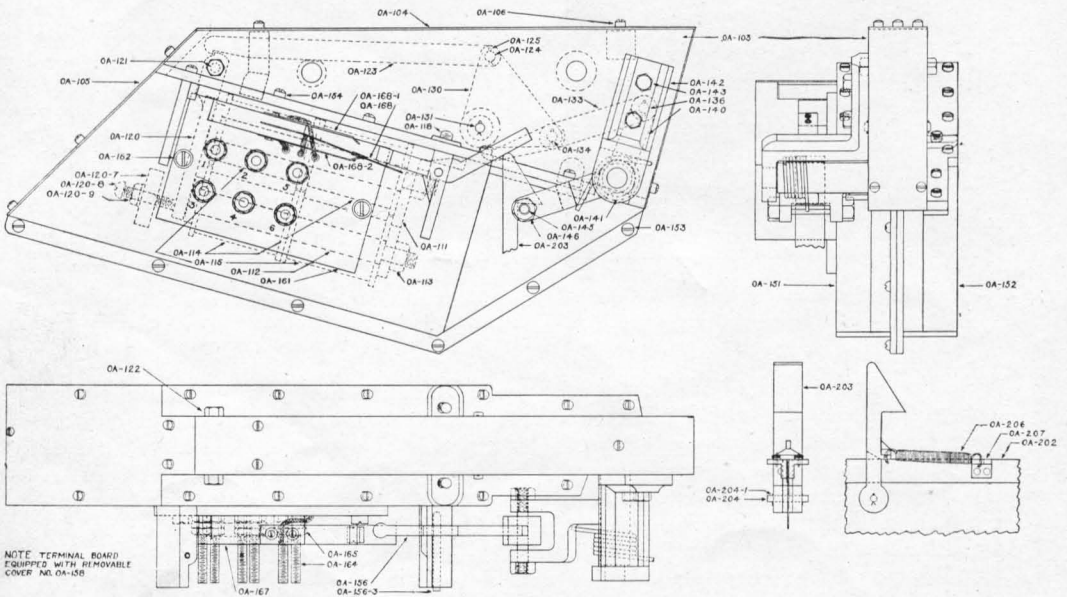

Drawing No. OA-101, Type OA-8 Auxiliary "Out-of-Order" Signal. (Mechanism Assembly)

## Parts for Type OA-8 Auxiliary "Out-of-Order" Signal

PART No.	NAME	PART No.	NAME
OA-101	Mechanism Assembly (Does not include banner, bracket or hood parts)	OA-170-5	Offset Bracket complete (For attaching to 5" standard pipe 5 $\frac{1}{8}$ " O. D.)
OA-103	Cast Iron Frame	OA-171	Upper Angle Iron—Right (To fit OA-1743 Pole Cap)
OA-104	Frame Cover Plate	OA-172	Upper Angle Iron—Left (To fit OA-1743 Pole Cap)
OA-105	Cover Plate (Armature End)	OA-1742-R	Lower Angle Iron—Right
OA-106	Machine Screws $\frac{1}{2}$ "x10/32 Fil. Hd. (For fastening cover piece)	OA-1742-L	Lower Angle Iron—Left
OA-107	Cap Screws $\frac{1}{2}$ "x3 $\frac{1}{2}$ " Hex. Hd. (Attaching mechanism to offset bracket)	OA-1743-4	Pole Cap Casting (To fit 4" standard pipe 4 $\frac{1}{2}$ " O. D.)
OA-108	Mechanism Pipe Spacer with Wood Bushing	OA-1743-45	Pole Cap Casting (To fit 4 $\frac{1}{2}$ " standard pipe 5" O. D.)
OA-109	Hood Spacer	OA-1743-5	Pole Cap Casting (To fit 5" standard pipe 5 $\frac{1}{8}$ " O. D.)
OA-110	Coil Assembly (includes Coils, Cores and Back Strap)	OA-1744-4	Pole Clamp—Right (To fit 4" standard pipe 4 $\frac{1}{2}$ " O. D.)
OA-111	Back Strap	OA-1744-45	Pole Clamp—Right (To fit 4 $\frac{1}{2}$ " standard pipe 5" O. D.)
OA-112	Magnet Cores with brass studs	OA-1744-5	Pole Clamp—Right (To fit 5" standard pipe 5 $\frac{1}{8}$ " O. D.)
OA-113	Hex. Nuts $\frac{3}{8}$ "x16	OA-1745-4	Pole Clamp—Left (To fit 4" standard pipe 4 $\frac{1}{2}$ " O. D.)
OA-114	Holding Coils (With lead wires)	OA-1745-45	Pole Clamp—Left (To fit 4 $\frac{1}{2}$ " standard pipe 5" O. D.)
OA-115	Release Coils (With lead wires)	OA-1745-5	Pole Clamp—Left (To fit 5" standard pipe 5 $\frac{1}{8}$ " O. D.)
OA-118	Cap Screws $\frac{1}{8}$ "x $\frac{3}{4}$ " Hex. Head	OA-1746	Machine Bolt $\frac{1}{2}$ "x6 $\frac{1}{2}$ "
OA-120	Armature Complete	OA-1747	Machine Bolt $\frac{1}{2}$ "x7 $\frac{1}{2}$ "
OA-121	Armature Pivot Pin	OA-1748	Machine Bolt $\frac{5}{8}$ "x1"
OA-122	Armature Trunnion	OA-1749	Machine Bolt $\frac{1}{2}$ "x1 $\frac{3}{4}$ "
OA-123	Armature Latch	OA-180	Back Banner Support
OA-124	Pivot Pin (Arm. Latch)	OA-181	Machine Bolts $\frac{5}{8}$ "x1 $\frac{1}{2}$ "
OA-125	Cotter $\frac{1}{16}$ "x $\frac{5}{8}$ " (Pivot Pin)	OA-184	Front Banner Support
OA-130	Bronze Toggle Link	OA-185	Machine Bolt $\frac{5}{8}$ "x1 $\frac{1}{2}$ " (For fastening front banner support)
OA-131	Toggle Link Pivot Pin	OA-186	Cap Screws $\frac{1}{2}$ "x4" (Banner Pivot)
OA-133	Toggle Lever	OA-187	Cap Screws $\frac{1}{2}$ "x4" (Banner Pivot)
OA-134	Pivot Pin (Toggle Lever)	OA-188	Hex. Nuts $\frac{1}{2}$ "x13 Th. (Banner Pivot)
OA-136	Crank Pin (Toggle Lever)	OA-190	Enameled Sheet Iron Hood Complete (For use with No. OA-170 Bracket)
OA-140	Releasing Crank	OA-190-A	Enameled Sheet Iron Hood Complete (For use with Adapter Bracket)
OA-141	Coil Spring (For Releasing Crank)	OA-191	Main Hood Member—Complete with Cover
OA-142	Releasing Crank Support	OA-193	Hood Cover Member only
OA-143	Cap Screws $\frac{5}{16}$ "x $\frac{3}{4}$ " Hex. Hd. (For attaching Releasing Crank Support to Offset Bracket)	OA-194	Machine Screw $\frac{5}{8}$ "x10/32 Round Hd.
OA-144	Lock Washers (Releasing Crank Support)	OA-198	Main Hood Member (Without Cover)
OA-145	Catch Rod	OA-199	Left Side Hood Member
OA-146	Hex. Nut $\frac{5}{16}$ "x18	OA-200	Enameled "Out-of-Order" Banner Complete (including catch and pipe banner rods)
OA-150	Aluminum Case Assembly (including right and left pieces)	OA-201	Enameled "Out-of-Order" Banner with Catch
OA-151	Right Case Piece (Aluminum)	OA-202	Enameled "Out-of-Order" Banner without Catch
OA-152	Left Case Piece (Aluminum)	OA-203	Banner Catch
OA-153	Machine Screws $\frac{3}{8}$ "x10/32 Rd. Hd. (Assembling Aluminum Case Pieces)	OA-204	Pivot Pin (Banner Catch)
OA-154	Machine Screws $\frac{1}{2}$ "x10/32 Fil. Hd. (Assembling Case and Frame)	OA-204-1	Cotter $\frac{1}{16}$ "x $\frac{5}{8}$ " (For Banner Catch Pivot)
OA-156	Contact Spacer Lever	OA-206	Coil Springs (Banner Catch)
OA-156-3	Pivot Pin (For Spacer Lever)	OA-207	Banner Catch Spring Support
OA-158	Terminal Board Cover	OA-210	Banner Rod (Complete with Tees)
OA-160	Terminal Board Assembly	OA-214	Cap Screws $\frac{1}{2}$ "x2 $\frac{1}{2}$ " Hex. Hd.
OA-161	Terminal Insulation Board	OA-215	Hex. Nuts $\frac{1}{2}$ "x13
OA-164	Machine Screws 1 $\frac{1}{2}$ "x14/24 R. H. (Binding Post)	OA-216	Pipe Spacer $\frac{3}{8}$ " long
OA-165	Hex. Nut 14/24	OA-217	Pipe Spacer 1 $\frac{3}{8}$ " long
OA-165-1	Brass Washer (For Binding Post)	OA-218	Cap Screws $\frac{1}{2}$ "x4" Hex. Hd. (Pipe Spacer Pivots)
OA-166	Switch Assembly (includes Insulation Board, Contacts, Bushings and Lead Wires)	OA-290	Terminal Board Adapter Wire (Complete with Terminals) (For adapting Flagman to operate with Auxiliary "Out-of-Order" Signal)
OA-167	Switch Insulation Board		
OA-168	Center Contact with Lead Wire		
OA-168-1	Upper Contact with Lead Wire		
OA-168-2	Lower Contact with Lead Wire		
OA-169-2	Insulating Washer (with two holes)		
OA-169-3	Insulating Bushing $\frac{1}{4}$ "x $\frac{5}{8}$ "		
OA-170-4	Offset Bracket complete (For attaching to 4" standard pipe 4 $\frac{1}{2}$ " O.D.)		
OA-170-45	Offset Bracket complete (For attaching to 4 $\frac{1}{2}$ " standard pipe 5" O. D.)		

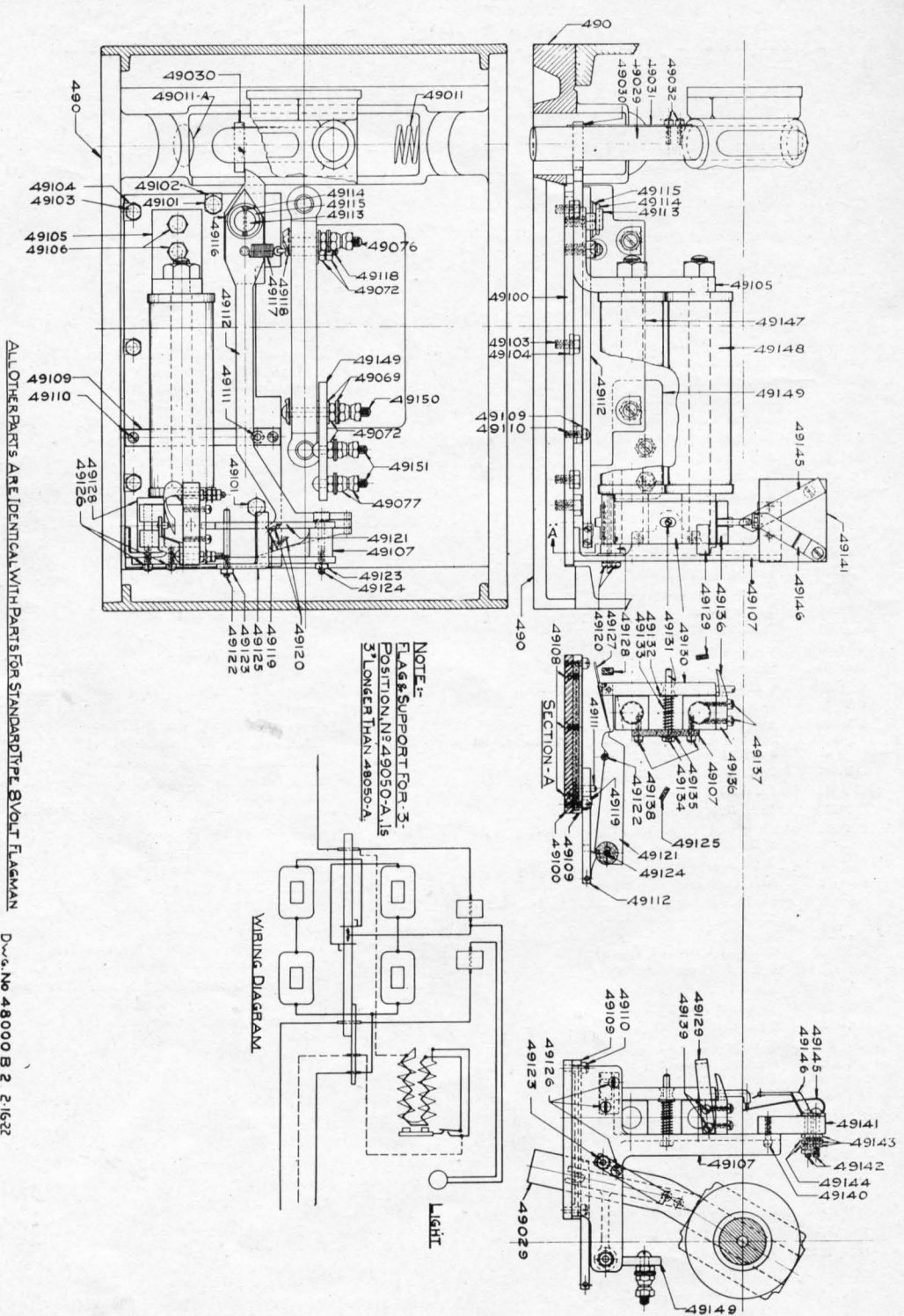

Dwg. No 48000 B 2 2-1632

Type LB Three-Position Magnetic Flagman

### Type LB Three Position Magnetic Flagman

The Magnetic Three-Position, or Hold Clear machine operates similarly to the two-position machine—with the addition of two holding coils and a mechanical latching device. When block is clear, the red flag is entirely concealed behind flag shield, and when train enters block the flag is released from shield—oscillating, at same time ringing gong, until train has passed out of block, when it again returns to position behind shield. Should for any reason hold-clear mechanism fail, flag would drop from shield and continue to oscillate until the latch picks it up, or the trouble located and repaired.

In the event of failure of electrical energy, the flag drops from shield to stationary "Danger" position, remaining in such position until trouble has been eliminated.

*The amount of current consumed and the cost of operation is no greater than that of the two-position machine on busy crossings.*

*The Three-Position Magnetic Flagman, like the Two-Position, is encased in a weather-proof housing, and its construction is both simple and durable—entirely accessible. Only two contacts are required for the complete operation, and because of the few wearing parts and absence of friction the mechanism is entirely reliable.*

Three Position Magnetic Flagmen are furnished as follows:

		WEIGHT CRATED FOR DOMESTIC SHIPMENT
LB-8	MAGNETIC WIGWAG FLAGMAN MECHANISM..... (Above for 8-volt direct current operation, no brake, three position, with bell, including Look-Listen shields)	275 lbs.
LB-600	MAGNETIC WIGWAG FLAGMAN MECHANISM..... (Above for 600-volt direct current operation, no brake, three position, with bell, including Look-Listen shields)	275 lbs.

### Parts for Type LB-8 (8-Volt D. C.) Standard Three Position Magnetic Flagman Drawing No. 48000-B-2

NUMBER	NAME	NUMBER	NAME
LB-49	8-volt D. C. Three Position Holding Mechanism Complete	LB-49031	Wire Spring for Lock Pin (Standard)
LB-50	600-volt D. C. Three Position Holding Mechanism Complete	LB-49032	Cap Screw 1/4"x1/2" Hex. Head
LB-49000	Main Base Casting 8-volt	LB-49042	Flagman Armature Casting
LB-49200	Main Base Casting 600-volt	LB-49100	Holding Mechanism Base
LB-49001	Sheet Iron Cap (Buffer Slot)	LB-49101	Cap Screw 5/8"x3/4" Hex. Head (For attaching holding mechanism to Flagman Base)
LB-49011	Flag Buffer Spring	LB-49102	Lock Washer 5/8" (Mechanism Base)
LB-49011-B	Rubber Flag Buffer (Substitute for LB-49011)	LB-49103	Cap Screw 1/4"x3/4" Hex. Head
LB-49011-A	Rubber Buffer	LB-49104	Lock Washer 1/4" (Mechanism Base)
LB-49029	Buffer Steel Rod (Must be drilled in machine so as to match lever arm and existent hole in armature)	LB-49105	Back Strap and Coil Support
LB-49029-A	Buffer Steel Rod (With Lock Pin and Spring)	LB-49106	Cap Screws 3/8"x3/4" Hex. Head Attaching Back Strap to Mechanism Base)
LA-49030	Lock Pin (Square—Obsolete)	LB-49107	Bronze Pole Piece Support
LB-49030	Round Lock Pin (Standard)	LB-491090	Lever Arm Guide Assembly (including Brass Guide and Stops)
LA-49031	Flat Spring for Lock Pin (Obsolete)	LB-49112	Lever Arm (Complete)
		LB-49H2-2	Lever Arm Detent



## Parts for Type LB-8 (8-Volt D.C.) Standard Three Position Magnetic Flagman—(Continued) Drawing No. 48000-B-2

NUMBER	NAME	NUMBER	NAME
LB-49112-4	Lever Arm Spring Hook	LB-49247	Lower Coil Only (With Lead Wires) (New type removable from core)
LB-49113	Lever Arm Pivot Stud	LB-49147-1	Lower Magnet Core and Pole Piece (For Removable Coils)
LB-49114	Cotter $\frac{1}{8}$ "x1" (Pivot Stud)	LB-49147-2	Hex. Iron Nut $\frac{1}{2}$ "x13 Th.
LB-49115	Iron Washer (Pivot Stud)	LB-49148	Upper Coil Assembly (including Coil, Core and Pole Piece)
LB-49116	Bronze Bearing Washer (Lever Arm)	LB-49248	Upper Coil Only (With Lead Wires) (New type removable from core)
LB-49117	Coil Spring (Lever Arm)	LB-49148-1	Upper Magnet Core and Pole Piece (For Removable Coils)
LA-49118-1	Adjusting Screw Support (Obsolete)	LB-49149	Insulation Terminal Board Extension
LA-49118	Lever Arm Spring Adjusting Screw (Obsolete)	LB-49150	Machine Screw 2"x14/24 Rd. Head
LB-49118	Lever Arm Spring Adjusting Screw (Standard)	LB-49151	Machine Screw 1 $\frac{1}{2}$ "x14/24 Rd. Head
LB-49119	Lever Arm Shoulder	LB-49152	Upper Spring Knuckle Casting
LB-49120	Machine Screws $\frac{1}{4}$ "x6/32 Round Head (Lever Arm Shoulder)	LB-491520	Upper Spring Knuckle Complete (Including Casting, Pipe and Cap)
LB-49121	Intermediate Lever	LB-49153	Lower Spring Knuckle Casting
LB-49122	Stop Pin (Intermediate Lever)	LB-49154	Aluminum Hood Complete (Including two pieces with screws)
LB-49123	Hex. Nut 10/32 (For Stop Pin)	LB-49155	Upper Coil Spring (Flag)
LB-49124	Intermediate Lever Pivot Screw	LB-49156	Lower Coil Spring (Flag)
LB-49124-1	Bronze Washer (Int. Lever Screw)	LB-49157	Upper Fibre Insulation
LB-49125	Intermediate Lever Stop	LB-49158	Middle Fibre Spool
LB-49126	Machine Screws $\frac{1}{2}$ "x10/32 Fil. Head	LB-49159	Lower Fibre Insulation
LB-49127	Armature Lever Catch	LB-49160	Knuckle Pin
LB-49128	Bronze Armature Bracket	LB-49161	Machine Bolt and Nut $\frac{3}{8}$ "x5" (For Springs)
LB-49129	Brass Armature Stop	LB-49162	Iron Washer (For Springs)
LB-49130	Armature Complete (including Armature Iron, Contact Spacer, Lever, Spring, Catch and Pivot Pin)	LB-49163	Cotter $\frac{3}{32}$ "x $\frac{3}{4}$ "
LB-49130-7	Armature Pivot Pin	LB-49164	Hex. Hd. Terminal Screws
LB-49131	Armature Spring Guide with Nut	LB-49165	Light Wires from Machine to Top Fibre (Without Terminal)
LB-49132	Brass Washer (Armature Spring)	LB-49165-1	Light Wire Terminals
LB-49133	Coil Spring (Armature)	LB-49166	Flag Light Wires (From Lamp to Fibre Bushing) (Without Terminals)
LB-49135	Lock Washer (Armature Spring Guide)	LB-49170	Enameled Flag (Including Lower Spring Knuckle Flag Pipe and Flag for hinged type light shields)
LB-49136	Magnet Pole Piece Extension	LB-49171	Enameled Flag Assembly (Including all parts; complete upper spring knuckle assembly, aluminum hoods, lower part flag assembly, springs, fibres, wiring, light shields, lenses and 5-watt Mazda lamp)
LB-49137	Machine Screws $\frac{3}{4}$ "x10/32 Fil. Hd.	LB-49180	Look Listen Shield Assembly, Complete (Including Side Pieces, braces and brackets)
LB-49138	Machine Screws $\frac{1}{2}$ "x10/32 Fil. Hd.	LB-49181-R	Right Side Look Listen Shield
LB-49139	Machine Screws $\frac{1}{2}$ "x10/32 Fil. Head	LB-49181-L	Left Side Look Listen Shield
LB-49140	Machine Screws $\frac{1}{2}$ "x10/32 Fil. Hd.	LB-49183	Upper Brace Look Listen Shield
LB-491410	Contact Insulation Board Complete (includes insulation Board, Flexible and Rigid Contacts, and Guide Pin)	LB-49184	Lower Brace Look Listen Shield
LB-49141	Contact Insulation Board Only	LB-49185	Angle Brackets Look Listen Shield
LB-49141-1	Contact Guide Pin and Nut		
LB-49143	Hex. Brass Nut 10/32		
LB-49144	Brass Washer		
LB-49145	Flexible Contact with Binding Post		
LB-49146	Rigid Contact with Binding Post		
LB-49147	Lower Coil Assembly (including Coil, Core and Pole Piece)		

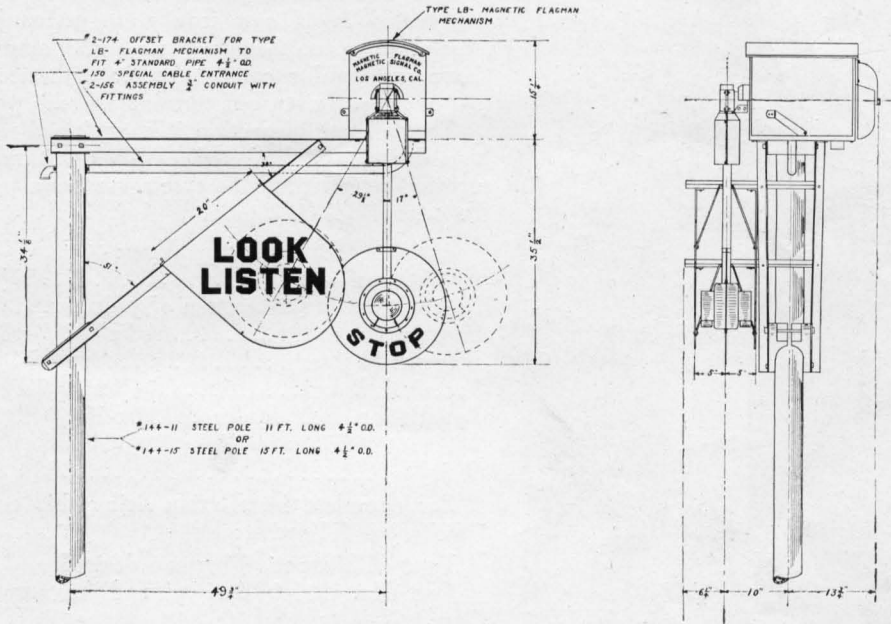

Drawing No. LB-101, Assembly Type LB Three Position Magnetic Flagman.

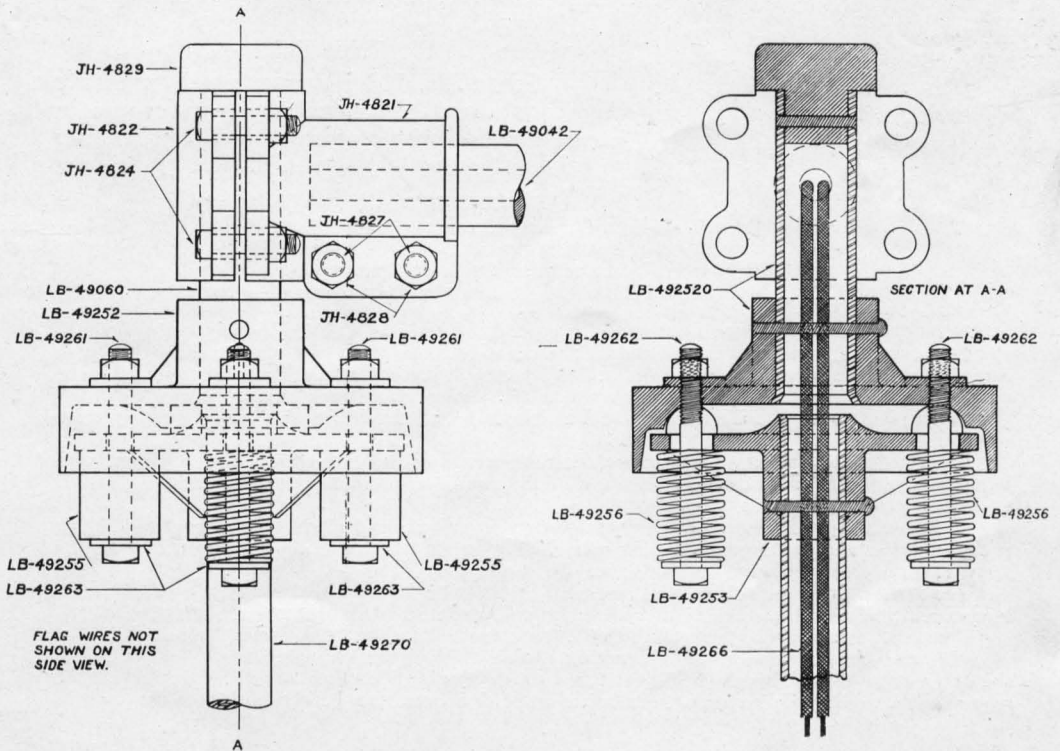

Drawing No. LB-1002, Improved Flag Spring Knuckle Assembly for Type LB Three Position Magnetic Flagman

## Style No. 104-4 Battery and Instrument Case

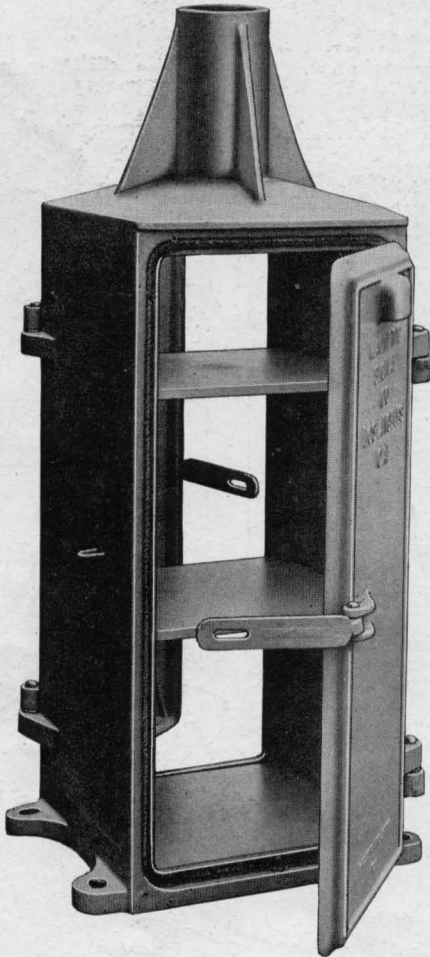

No. 104-4 Battery and Instrument Case illustrated is of cast iron construction designed to accommodate twelve 500 ampere hour rectangular cells, together with necessary relays, resistances, terminals, etc.

To facilitate inspection it is equipped with two doors, well gasketed, also ventilators to prevent sweating. This case serves as a pole base for 4½" O.D. pole.

### Dimensions follow:

Height over all.....55¼"  
 Base of housing to bottom of pole.....44"  
 Shelves (three) .....5/8" x 147/8" x 17"  
 Between Shelves .....14¼"  
 Terminal Board .....3/4" x 8½" x 15"  
 Foundation Bolt Holes...13" x 20½" C to C  
 (1" bolts)

Weight .....500 lbs.

For complete installation using this case, specify the following:

Type of Magnetic Flagman desired.

One No. 104-4 Battery and Instrument Case.

One No. 144-11 Steel Pole (Base of housing to bottom of flag 12')

One No. 174-4 Offset Bracket.

Three No. 180-4 Double Pole Steps.

One No. 156 Assembly ¾" conduit and fittings.

One No. 150 Cable Entrance.

STYLE NO. 103 BATTERY AND INSTRUMENT CASE should be specified when for use in connection with storage, or primary batteries other than rectangular in shape.

## Track Instruments

"FUSTICLO" RAIL CONTACT CIRCUIT CONTROLLER  
 ORDER REFERENCE

MODEL C-1 "FUSTICLO" DIRECTIONAL CONTACT CIRCUIT CONTROLLER

MODEL C-2 "FUSTICLO" NON-DIRECTIONAL RAIL CONTACT CIRCUIT CONTROLLER

NOTE: Above materials carried in stock at Los Angeles, or may be shipped from factory at Louisville.

"Fusticlo" track instruments are used for controlling highway crossing signals, train annunciators, etc., on steam and electric railroads. The use of Fusticlo track instruments eliminates track batteries with housing, bond wires, insulated rail joints, switch-rod insulations, wire connections to rails with housing, and interlocking relays which are required with track circuit control.

In AUTOMATIC SIGNAL TERRITORY the Fusticlo is installed without disturbing existing track circuits.

The Fusticlo track instruments are operated by means of rail deflection, being equipped with Vanadium Spring Steel Plates, which assure a deflection of approximately three-eighths inch when the train passes over it.

The MODEL C-1 is directional and used for starting operation of signal, the arrangement being such that trains approaching the crossing will make or break contacts as desired, but trains passing away from the crossing do not operate them.

The MODEL C-2 is non-directional and used for stopping operation of signal, the arrangement being such that trains passing in either direction will make or break contacts as desired.

CIRCUITS. Number 451 illustrating single track operation using track instruments is shown on page 48, and circuit number 455 illustrating double track operation using track instruments is shown on page 48. We would be pleased to furnish circuits for other situations than above on request; also, additional literature, installation instructions, etc., can be obtained from us.

Cut at right illustrates center of highway installation of Upper Quadrant Magnetic Wigwag Flagman. Flag plainly visible in either direction.

Assembly complete, as shown at right, consists of the following:

- 1 UPPER QUADRANT MAGNETIC WIGWAG FLAGMAN MECHANISM.  
(Specify type desired.)
- 1 No. 108-4 CAST IRON POLE BASE, to fit 4½" O. D. Pole.
- 1 No. 144-15 STEEL POLE, 4½" O. D. 15' long—or length desired.
- 4 No. 180-4 CAST IRON POLE STEPS, (Double Pattern)—or number desired.
- 1 No. 114-4 UPPER QUADRANT MECHANISM SUPPORT CASTING.  
(To fit 4½" O. D. Pole.)
- 1 No. 150 SPECIAL CABLE ENTRANCE.

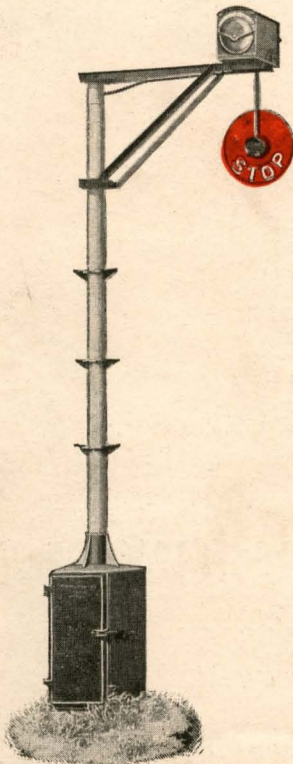
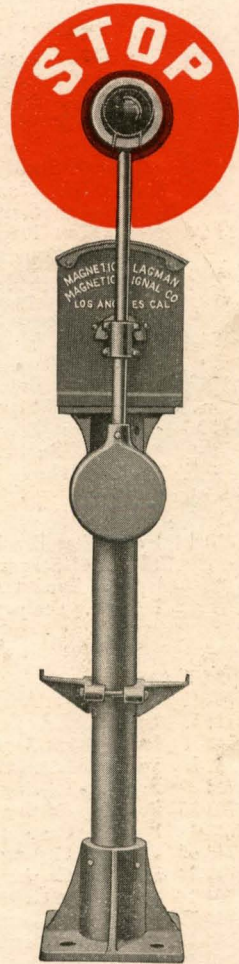

Cut at left illustrates standard installation of lower quadrant Magnetic Wigwag Flagman at side of highway.

Assembly complete, as shown at left, consists of the following:

- 1 MAGNETIC WIGWAG FLAGMAN MECHANISM.  
(Specify type desired)
- 1 No. 104-4 BATTERY AND INSTRUMENT CASE.
- 1 No. 144-11 STEEL POLE, 11' long 4½" O. D.
- 1 No. 174-4 OFFSET BRACKET COMPLETE.
- 3 No. 180-4 CAST IRON POLE STEPS—DOUBLE PATTERN.
- 1 No. 156 ASSEMBLY ¾" IRON CONDUIT, with fittings for bringing wires from signal mast to mechanism.
- 1 No. 150 SPECIAL CABLE ENTRANCE.

*Flags of special design manufactured to meet individual requirements.*

### Angle Iron Offset Brackets

(For Attaching Flagman Mechanism to Pole)

PART NO.	NAME	NET WEIGHT—POUNDS
174-3	Iron Offset Bracket..... (To fit 3" Standard Pipe 3½" O. D.)	75
174-35	Iron Offset Bracket..... (To fit 3½" Standard Pipe 4" O. D.)	73
174-4	Iron Offset Bracket..... (To fit 4" Standard Pipe 4½" O. D.)	70
174-45	Iron Offset Bracket..... (To fit 4½" Standard Pipe 5" O. D.)	70
174-5	Iron Offset Bracket..... (To fit 5" Standard Pipe 5-9/16" O. D.)	72
174-10	Iron Offset Bracket..... (To fit wood pole at 10½" diameter section)	45
<b>Note: Above brackets No. 174 used with two position Flagman only.</b>		
2-174-45	Iron Offset Bracket..... (To fit 4" Standard Pipe 4½" O. D.)	70
2-174-45	Iron Offset Bracket..... (To fit 4½" Standard Pipe 5" O. D.)	70
2-174-5	Iron Offset Bracket..... (To fit 5" Standard Pipe 5-9/16" O. D.)	72
<b>Note: Above brackets No. 2-174 used with three position Flagman only.</b>		

### Special Offset Brackets

1710-4	Iron Offset Bracket 10' long..... (To fit 4" Standard Pipe 4½" O. D.)	295
<b>NOTE: Type OA-8 Auxiliary "Out of Order" signal includes Special Offset Bracket. See parts listed on page 29.</b>		

### Parts for Standard Offset Brackets

PART NO.	NAME
1741-R	Upper Right Angle Iron 3/16"x2"
1741-L	Upper Left Angle Iron 3/16"x2"
1742-R	Lower Right Angle Iron 1/8"x1½"
1742-L	Lower Left Angle Iron 1/8"x1½"
1743-3	Pole Cap Casting (For 3" Standard Pipe 3½" O. D.)
1743-35	Pole Cap Casting (For 3½" Standard Pipe 4" O. D.)
1743-4	Pole Cap Casting (For 4" Standard Pipe 4½" O. D.)
1743-45	Pole Cap Casting (For 4½" Standard Pipe 5" O. D.)
1743-5	Pole Cap Casting (For 5" Standard Pipe 5-9/16" O. D.)
1744-3	Pole Clamp Casting, Right (For 3" Standard Pipe 3½" O. D.)
1744-35	Pole Clamp Casting, Right (For 3½" Standard Pipe 4" O. D.)
1744-4	Pole Clamp Casting, Right (For 4" Standard Pipe 4½" O. D.)
1744-45	Pole Clamp Casting, Right (For 4½" Standard Pipe 5" O. D.)
1744-5	Pole Clamp Casting, Right (For 5" Standard Pipe 5-9/16" O. D.)
1745-3	Pole Clamp Casting, Left (For 3" Standard Pipe 3½" O. D.)
1745-35	Pole Clamp Casting, Left (For 3½" Standard Pipe 4" O. D.)
1745-4	Pole Clamp Casting, Left (For 4" Standard Pipe 4½" O. D.)
1745-45	Pole Clamp Casting, Left (For 4½" Standard Pipe 5" O. D.)
1745-5	Pole Clamp Casting, Left (For 5" Standard Pipe 5-9/16" O. D.)
1746	Machine Bolt ½"x6½"
1747	Machine Bolt ½"x7½"
1748	Machine Bolt 5/8"x1"
1749	Machine Bolt ½"x1¾"

### Parts for No. 174-10 Bracket to Fit Wood Pole at 10½-Inch Diameter Section

PART NO.	NAME	PART NO.	NAME
17481-R	Upper Right Angle Iron 3/16"x2"	17485	Stud Bolt 5/8"x13"
17481-L	Upper Left Angle Iron 3/16"x2"	17486	Hex. Nut 5/8"x11Th.
17482-R	Lower Right Angle Iron 1/8"x1½"	17487	Lag Bolt ½"x4"
17482-L	Lower Left Angle Iron 1/8"x1½"		

### Parts for No. 2-174 Bracket for Three Position Flagman Only

PART NO.	NAME	PART NO.	NAME
2-1741-R	Upper Right Angle Iron 3/16"x2"	2-1742-R	Lower Right Angle Iron 1/8"x1½"
2-1741-L	Upper Left Angle Iron 3/16"x2"	2-1742-L	Lower Left Angle Iron 1/8"x1½"

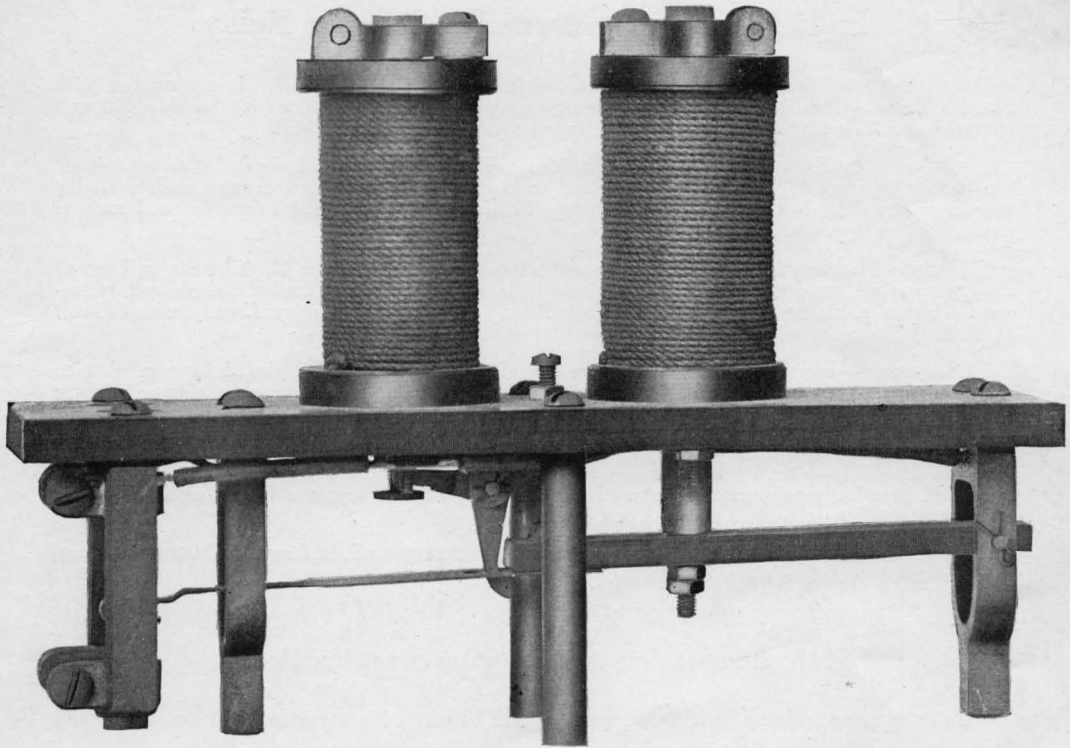

### No. 502 Simplex Relay

WIDTH	LENGTH	HEIGHT	SHIPPING WEIGHT
3 $\frac{1}{4}$ "	8 $\frac{5}{8}$ "	6 $\frac{1}{2}$ "	8 lbs.

The No. 502 improved Simplex Relay is the result of much experimental and development work, and is now highly recommended as a thoroughly reliable and substantial device for use in connection with high voltage D.C. signals.

Many large electric lines are using the improved Simplex at locations where there is frequent service coupled with varying speed and voltage—it is found highly satisfactory under all conditions.

#### Operation

The Simplex Relay is of solenoid type and designed primarily for the control of crossing signals on Electric Lines utilizing available trolley current for operation together with trolley brush or other impulse type contacts. Relay is normally de-energized and in normal position, armature contact bar is held in neutral position between upper and lower stationary contacts. The passing of trolley wheel over starting contacts, momentarily energizes starting coil, unlatching armature and closing circuit to crossing signal across lower carbon contacts. As trolley wheel passes stop contact, stop coil is momentarily energized relatching armature to normal position. In event of a shorted trolley contact, crossing signal operates, giving danger indication either across upper or lower contacts of relay. The rugged construction of the Simplex Relay, together with its rigid mounting, eliminates jar and vibration.

*See Page 38 for maintenance instructions*

## Installation Instructions for Simplex Relay

We recommend the use of our No. 340 Wood Instrument Case (Page 40) in conjunction with Simplex Relay. This case is completely equipped with necessary fixtures for reliable 600 volt operation. Wiring of case may be arranged to meet particular specifications.

**MOUNTING OF RELAY**—No. 340 Case provides a  $\frac{3}{8}$ -inch ebony board shelf, drilled to support one to four relays, using No. 50275 base board terminal pins (furnished with each relay). Relay may be removed by loosening wing nuts (Page 39), allowing convenient inspection and maintenance.

**WIRING**—Diagrams for Instrument Case and relays are shown on Page 42. Circuits on Page 47 show general wiring diagrams for installation of Magnetic Flagman, Simplex Relays and Instrument Case on single and double track electric lines. *Do not connect relay directly with 600-volt D. C. line, but use specified resistances.*

**CONDENSERS**—We recommend condensers for all installations, to be placed in parallel with relay contacts. This is particularly important where relay is used to operate extra side or advance lights or where more than one flagman is operated in parallel.

**VOLTAGE**—The normal line voltage for operation of Simplex Relay is 600-V D.C. Relay will operate reliably, however, on line voltage as low as 175. Minimum voltage across relay coil terminals is 60 volts, maximum 200 volts. Resistors with variable taps are furnished to allow for adjustment for lowest voltage at any given location.

**LIGHTNING ARRESTORS** should be used on all wires except ground, leading into Instrument Case, in districts subjected to electrical storms.

## Maintenance Instructions for Simplex Relay

An extra relay and supply of repair parts should be carried in stock to facilitate repairs and part renewals when necessary.

The following is of great importance as regards inspection and maintenance of relay:

Attach relay securely to baseboard by tightening wing nuts.

Parts should be kept clean. Use no oil or grease. Keep all adjustments locked and screws and nuts well tightened.

Cotter key points should be well spread.

**CONTACTS**—Keep brass and carbon contacts Nos. 50216 and 50216-A filed clean and level. Readjust when necessary, tightening clamp screws. Keep contact bar No. 50217 cleaned and straight, maintaining free and easy end and side movement to allow self centering when making contact with carbons. In normal position contact bar should be centered to allow a minimum of  $\frac{3}{8}$  inch distance between contact bar and upper as well as lower contacts. Replace contacts immediately if in poor condition.

**COUNTERWEIGHT** must be rigidly clamped in such position as to allow insulating arm and contact to freely drop on release of latch.

**PLUNGERS** No. 50207 and 50208—Maintain free and easy movement. Remove for cleaning if rust or dirt appears. Lock nuts on stopping solenoid plunger should be kept properly adjusted and tight to allow free movement of Insulating Arm No. 50225.

**STATIONARY CORES** No. 50206—Must be rigidly held in place by Threaded Core Clamps No. 50203. Adjust Stationary Cores only when absolutely necessary by loosening Clamp Jam Nut. Tighten Jam Nut after adjustment is made. Stopping Coil Stationary Cores are adjusted to allow only enough tension of Armature Contact Bar No. 50217 against upper brass contacts to assure positive contact while coil is energized. Starting Coil Stationary Core is adjusted to allow Latch No. 50228 to clear, and maintain quick and positive action.

Latch Stop Adjusting Screw No. 50210 should be adjusted and locked with lock nut to allow free clearance between Insulating Arm No. 50225 and side of Latch No. 50228. Undue friction should not be allowed between these parts at any time.

Relay coils may be readily removed by loosening Coil Nuts No. 50232 beneath relay base. In replacing coils, nuts should be tight and locked, though unreasonable tightening will break the supporting screws.

## No. 502 Simplex Relay

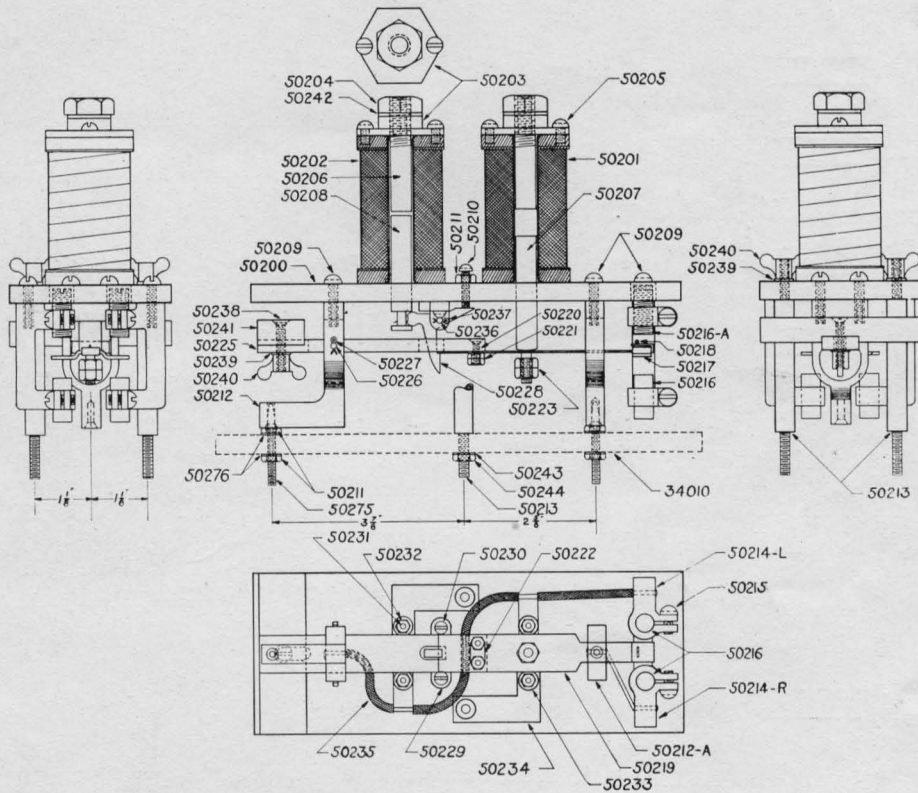

### Parts for Type No. 502 D. C. Simplex Relay

*50200	Base	50222	Copper Lock (Cont. Finger)
*50201	Stop Coil	50223	Hex Iron Nuts 10-32 (Stop Coil Plunger)
*50202	Start Coil	*50225	Insulating Arm
*50203	Stationary Core Support	50226	Ins. Arm Pivot Pin
*50204	Hex Jam Nut $\frac{7}{16}$ " x 14 Th.	50227	Cotter $\frac{1}{16}$ " x $\frac{1}{2}$ " (Pivot Pin)
*50205	Machine Screw $\frac{3}{8}$ " x 10-32 R.H.	50228	Latch
*50206	Stationary Core	50229	Latch Bracket
50207	Stop Coil Plunger	50230	Mach. Screws $\frac{1}{2}$ " x 8-32 R. H. (Latch Bracket)
50208	Start Coil Plunger	50231	Mach. Screws 1" x 6-32 Fl. Hd. (Coils)
50209	Machine Screw $\frac{7}{8}$ " x 10-32 R.H.	50232	Hex Brass Nuts 6-32 (Coils)
50210	Machine Screw $\frac{3}{4}$ " x 10-32 R.H. (Latch Adj.)	50233	Brass Washer No. 6 (Coils)
50211	Hex Brass Nut 8-32	50234	Flat Copper Connection
*50212	Offset Bracket Leg—Back	50235	Connection Wire
*50212-A	Cast Bracket Leg—Front	50236	Latch Pivot Pin
50213	Round Bracket Post (For shelf attachment)	50237	Cotter $\frac{1}{16}$ " x $\frac{1}{2}$ " (Pivot Pin)
50214-R	Cast Contact Support—Right	50238	Mach. Screw 1" x 10-32 Fl. Hd. (Counterweight)
50214-L	Cast Contact Support—Left	50239	Spring Lock Washer $\frac{1}{16}$ "
50215	Mach. Screws $\frac{3}{8}$ " x 10-32 R.H.	50240	Brass Wing Nut 10-32
50216	Lower Carbon Contacts	50241	Counterweight
*50216-A	Upper Brass Contacts $\frac{1}{16}$ " x 14 Th.	50242	Spring Lock Washer $\frac{1}{16}$ "
50217	Flat Contact Bar	50243	Brass Washer No. 10
50218	Cotter $\frac{1}{16}$ " x $\frac{1}{2}$ " (Contact Bar)	50244	Hex Brass Nuts 10-32
50219	Contact Finger	50275	Base Board Terminal Pins
50220	Mach. Screw $\frac{1}{2}$ " x 6-32 Fl. Hd. (Cont. Finger)	50276	Brass Washer No. 8
50221	Hex Brass Nuts 6-32 (Cont. Finger)		

\*—Parts not interchangeable with obsolete type No. 501. Relay: Order as follows:

50100	Base	50103	Core Clamp
50101	Stop Coil	50104	Core Clamp Screw
50102	Start Coil	50106	Stationary Core
	(Order new coils complete with Threaded Stationary Core)	50112	Cast Armature Support Leg
		50116-A	Brass Contacts—Not Threaded
		50125	Insulating Arm



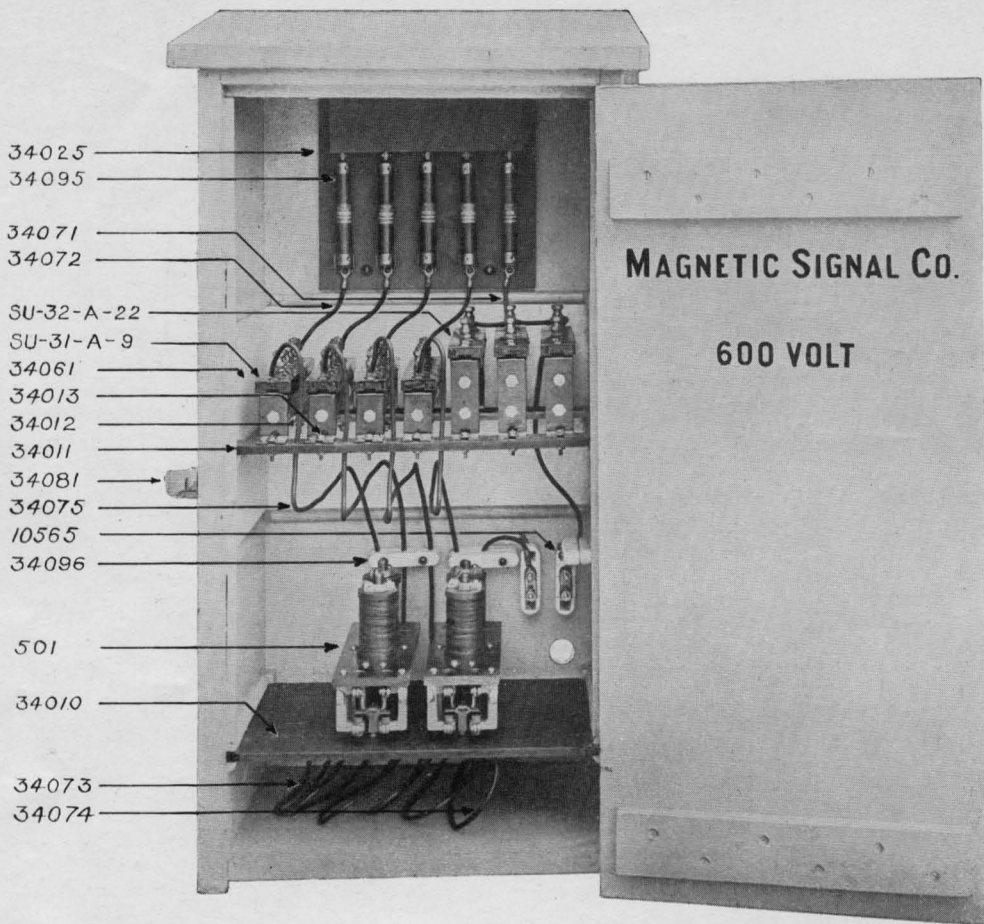

No. 340 Wood Instrument Case, Complete with Relays.

**Parts for No. 340 Wood Instrument Case**

PART NUMBER	NAME	PART NUMBER	NAME
34000	Case Only, Galvanized covered (Asbestos lined. Does not include inside fixtures or pole fittings)	34051-45	Pole Support (To fit 4½" steel pipe 5" O. D.)
34010	Insulation Terminal Board (For mounting relays) (Does not include Terminal Pins)	34051-5	Pole Support (To fit 5" steel pipe 5-9/16" O. D.)
34011	Front Insulation Resistor Support	34052-9	Top Pole Support (To fit wood pole at 9" diameter section)
34012	Back Insulation Resistor Support	34052-12	Top Pole Support (To fit wood pole at 12" diameter section)
34013	8/32" Brass Studs (For attaching Resistors to Supports)	34053-9	Bottom Pole Support (To fit wood pole at 9" diameter section)
34016	Terminal Board Pins	34053-12	Bottom Pole Support (To fit wood pole at 12" diameter section)
34021	Strap Iron Brackets (For attaching case to pole supports for wood poles)	34054-4	Cast Iron Pole Clamp (To fit 4" steel pipe 4½" O. D.)
34025	5 Point Single Throw Switch Complete (With fibre guard. Does not include fuses)	34054-45	Cast Iron Pole Clamp (To fit 4½" steel pipe 5" O. D.)
34028	Fibre Switch Guard only	34054-5	Cast Iron Pole Clamp (To fit 5" steel pipe 5-9/16" O. D.)
34051-4	Pole Support (To fit 4" steel pipe 4½" O. D.)	34061	Asbestos lining 37½"x11"

**Parts for No. 340 Wood Instrument Case (Continued)**

34071	Connection Wire 3½" long, complete with terminals	34084	Wood Screw ¾"x 8 Flat Head
34072	Connection Wire 5½" long, complete with terminals	34085	Wood Screw 1½"x10 Flat Head
34073	Connection Wire 14½" long, complete with terminals	34086	Wood Screw 1½"x12 Flat Head
34074	Connection Wire 32" long, complete with terminals	34087	Wood Screw 2½"x14 Flat Head
34075	Connection Wire 48" long, complete with terminals	34093	Wood Screw 1¼"x 9 Round Head
34077	Bee Wire Terminals	34094	Wood Screw 2 "x10 Round Head
34078	Special Copper Terminals	34095	10 amp, 600-volt Enclosed Cartridge Fuses (Non-Indicating)
34081	4½" Hasp and Staple	34096	Unglazed Porcelain Cleats
34082	4" Heavy T Hinge	SU-31-A-9	Resistor (See Schedule below)
34083	Wood Screw ¾"x7 Flat Head	SU-32-A-24	Resistor (See Schedule below)
		10565	Terminal Block (See Schedule A.R.A. Terminals below)

**CR-9153 Type SU Enamelled Signal Resistors  
Complete Resistor Units**

SU-31-A-7	Signal Resistor 8000 ohms total (With four taps making four sections of 500 ohms each and one section of 6000 ohms)	SU-31-A-13	Signal Resistor 1000 ohms total (With three taps making four sections of 250 ohms each)
SU-31-A-9	Signal Resistor 3250 ohms total (With four taps making four sections of 250 ohms each and one section of 2250 ohms)	SU-32-A-22	Signal Resistor 2000 ohms total
SU-31-A-12	Signal Resistor 6000 ohms total (With four taps making four sections of 500 ohms each and one section of 4000 ohms)	SU-32-A-24	Signal Resistor 4000 ohms total
		SU-32-A-25	Signal Resistor 1000 ohms total (One 80-watt tube only mounted on SU-32-A Bracket)

**Resistor Tubes Only for Above Units (Without Frames)**

SU-31-A-7	Signal Resistor Tube only, 8000 ohms total (With four taps making four sections of 500 ohms each and one section of 6000 ohms)	SU-31-A-13	Signal Resistor Tube only, 1000 ohms total (With three taps making four sections of 250 ohms each)
SU-31-A-9	Signal Resistor Tube only, 3250 ohms total (With four taps making four sections of 250 ohms each and one section of 2250 ohms)	SU-31-A	Signal Resistor Tube only, 1000 ohms total (Used on units SU-32-A-22 and SU-32-A-25)
SU-31-A-12	Signal Resistor Tube only, 6000 ohms total	SU-32-A-24	Signal Resistor Tube only, 2000 ohms total

**Resistor Frames Only for Type SU Resistor Units (Without Resistor Tubes or Binding Posts)**

SU-31	Resistor Frame (For one tube)	SU-34	Resistor Frame (For four tubes)
SU-32	Resistor Frame (For two tubes)	SU-36	Resistor Frame (For six tubes)
SU-33	Resistor Frame (For three tubes)		

**Binding Post for Type SU Resistor Unit (A.R.A. Signal Section Standard)**

107010	Binding Post Complete, 1½" long (Consists of bolt, two binding nuts, two clamp nuts and three washers)	10709	Bolt only, 1½" long (Square Head)
--------	---	-------	-----------------------------------

**Terminal Blocks (Porcelain) (A.R.A. Signal Section Standard)**

10563	A.R.A. Terminal Block Assembly (1" distance between binding posts center to center)	10566	Binding Post 14/24 complete, 1½" long
10565	A.R.A. Terminal Block Assembly (2¾" distance between binding posts center to center)	10567	Binding Post only, 14/24, 1½" long
10562	Connector (For No. 10563)	10706	Binding Nut
10564	Connector (For No. 10565)	10707	Clamp Nut
		10708	Washer

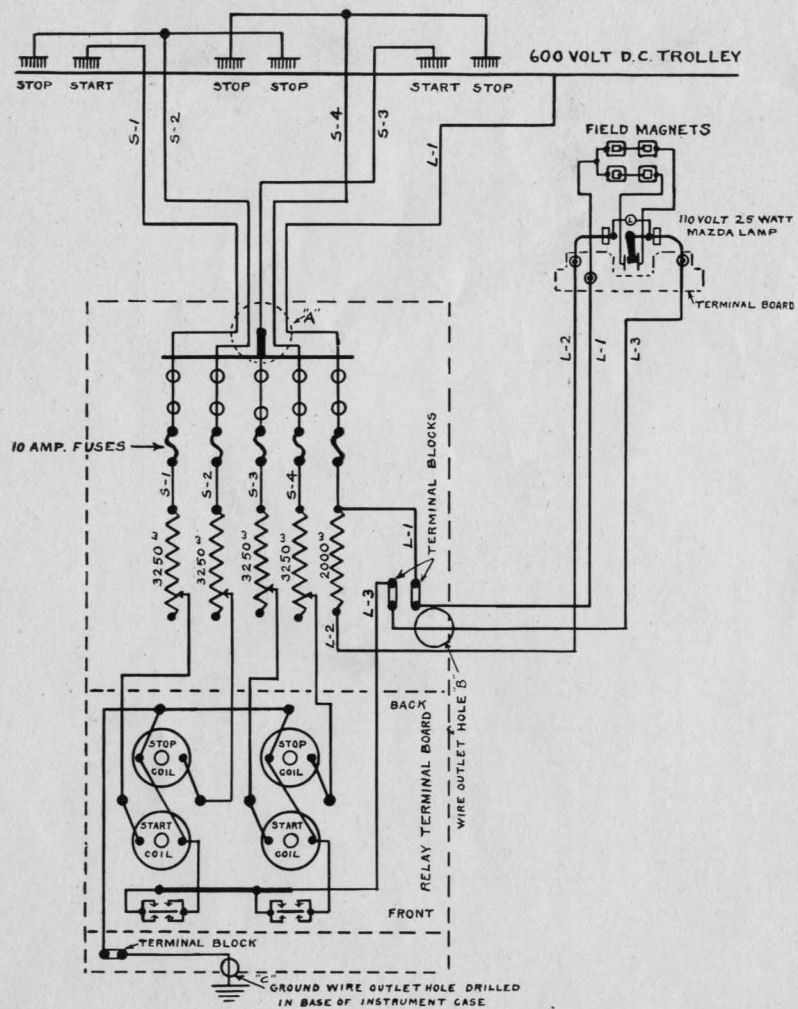

Circuit No. 340-102, For No. 340 Instrument Case, 600-Volt D.C. Trolley Operation of Magnetic Flagman. Trolley Brush Control.

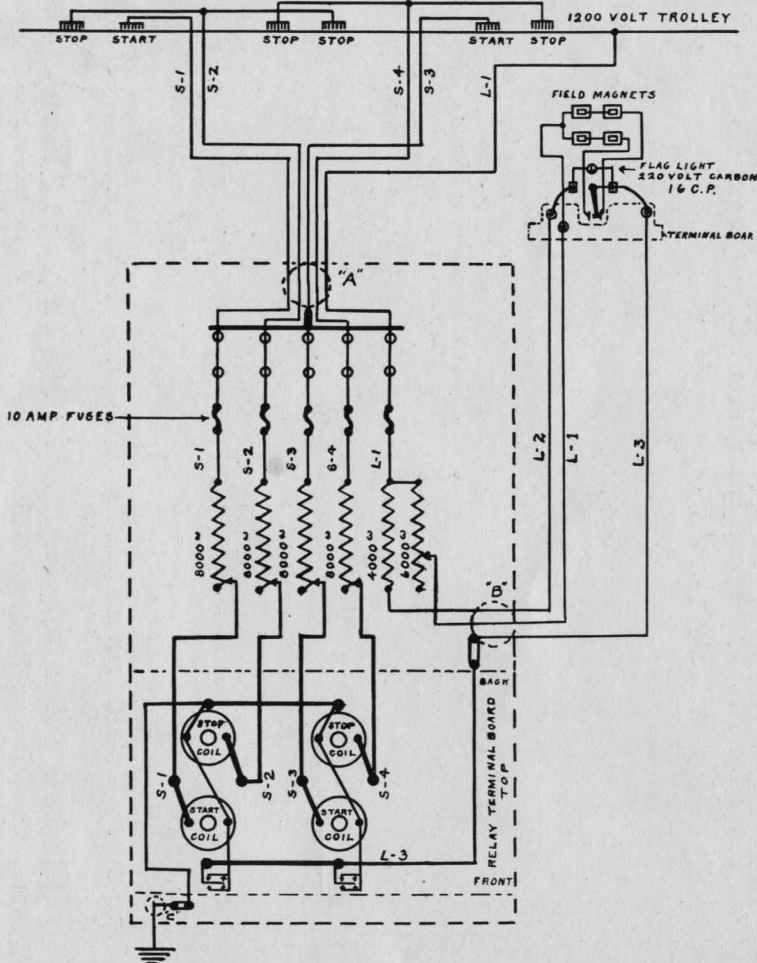

Circuit No. 350-101, For No. 350 Instrument Case, 1200-Volt D.C. Trolley Operation of Magnetic Flagman. Trolley Brush Control.

### Magnetic Flagman Circuits

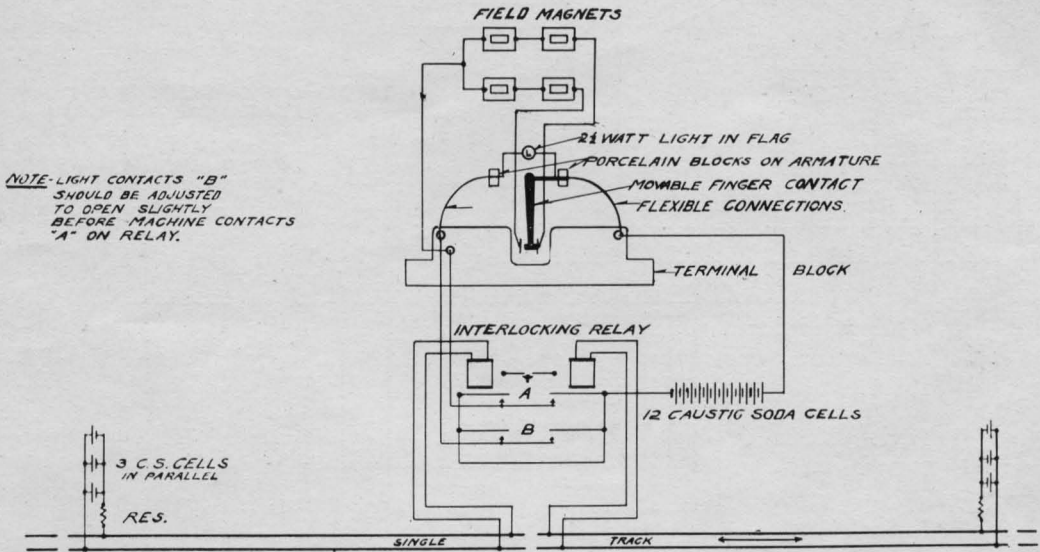

Circuit No. 411. 8-volt D.C. (Caustic Soda Battery) installation of Magnetic Flagman on single track steam line. Traffic in both directions. Signal controlled by D.C. track circuits.

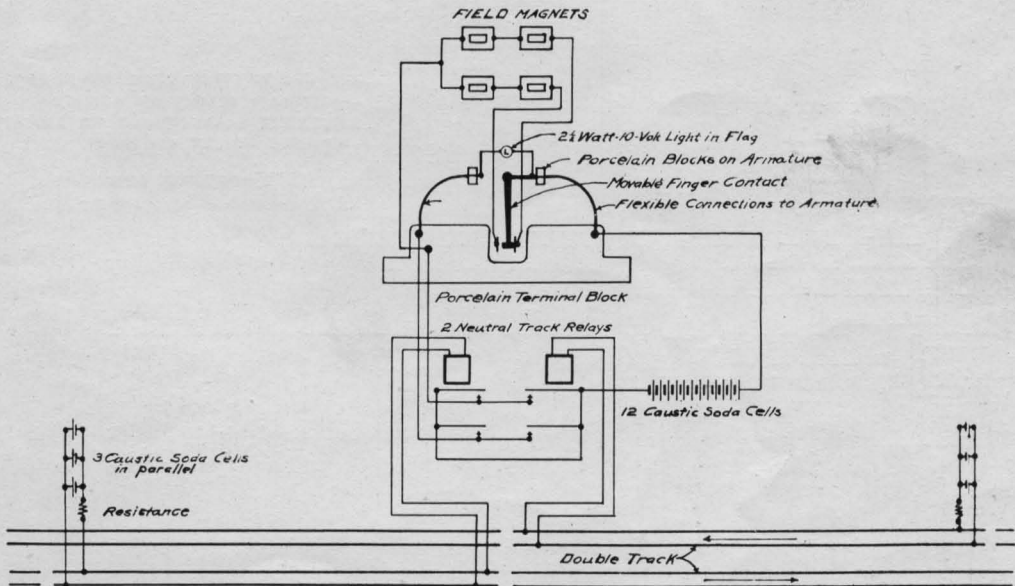

Circuit No. 410. 8-volt D.C. (Caustic Soda Battery) installation of Magnetic Flagman on double track steam line. Signal controlled by D.C. track circuits.

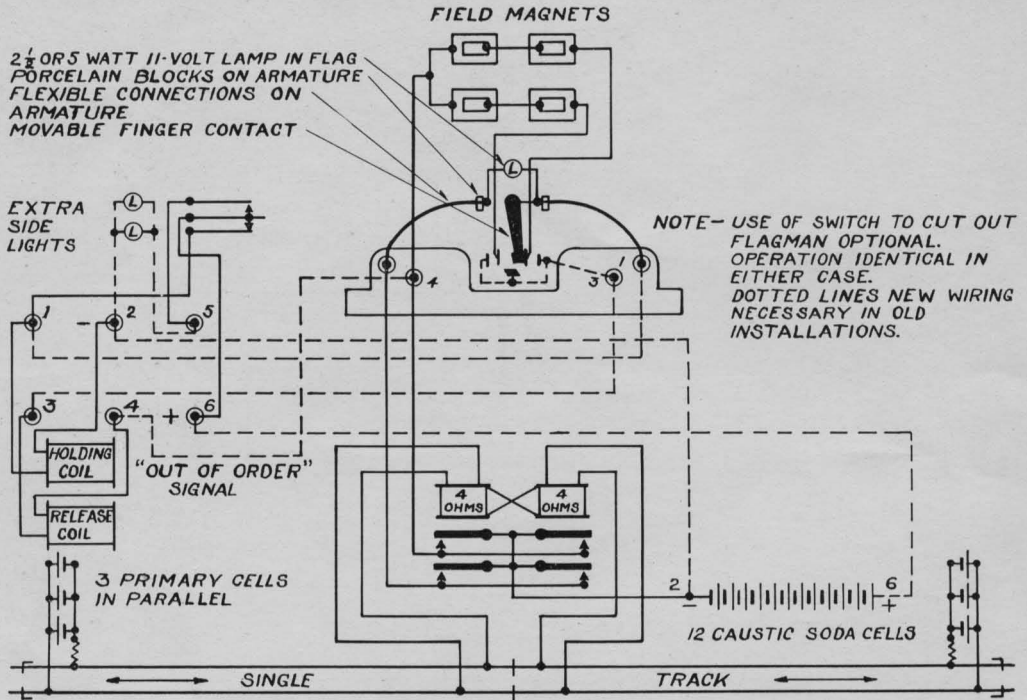

Circuit No. 462. Single Track Steam Line Operation of Magnetic Flagman and Auxiliary "Out of Order" Installation. D.C. Track Circuit Control.

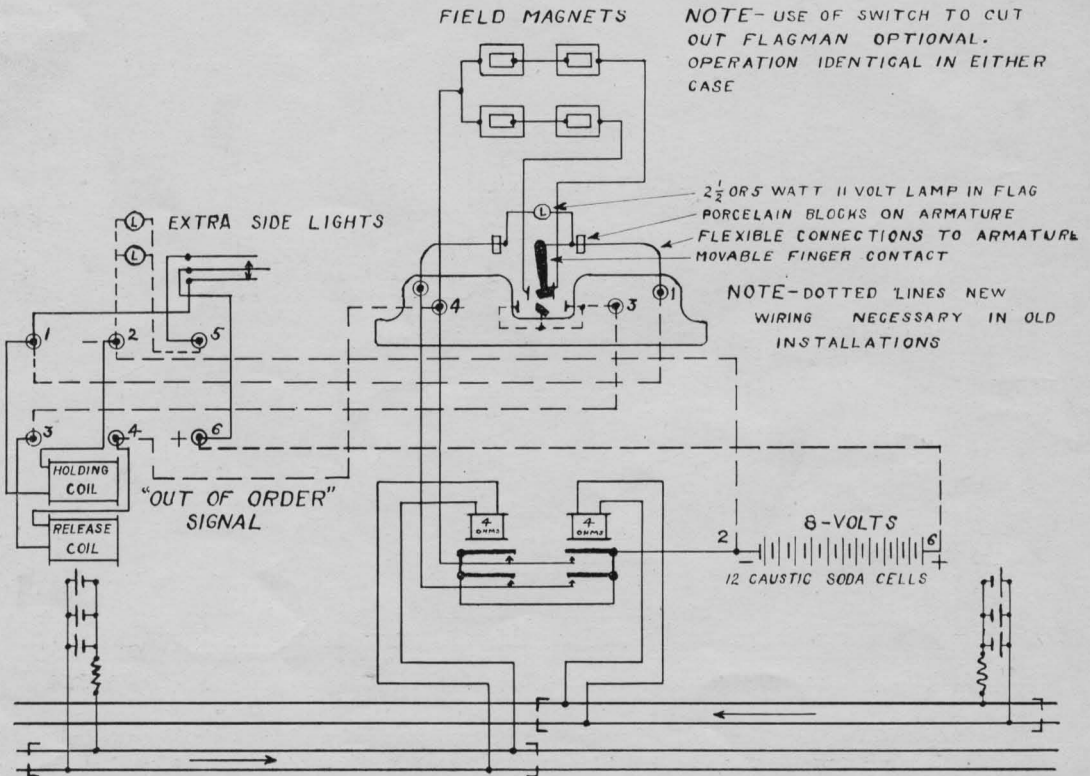

Circuit No. 461. Double Track Steam Line Operation of Magnetic Flagman and Auxiliary "Out of Order" Installation. D.C. Track Circuit Control.

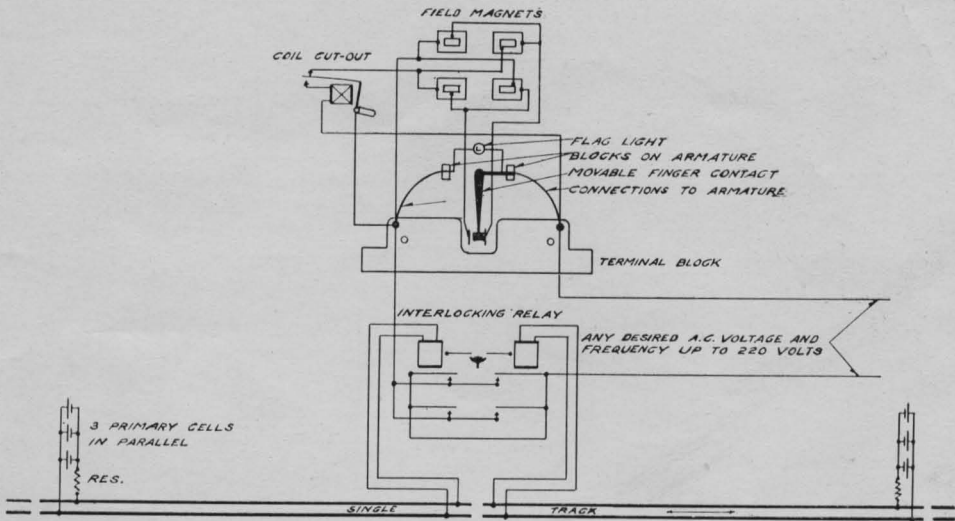

Circuit No. 417. Alternating Current installation of Magnetic Flagman on single track steam line. Traffic in both directions. Signal controlled by D.C. track circuits.

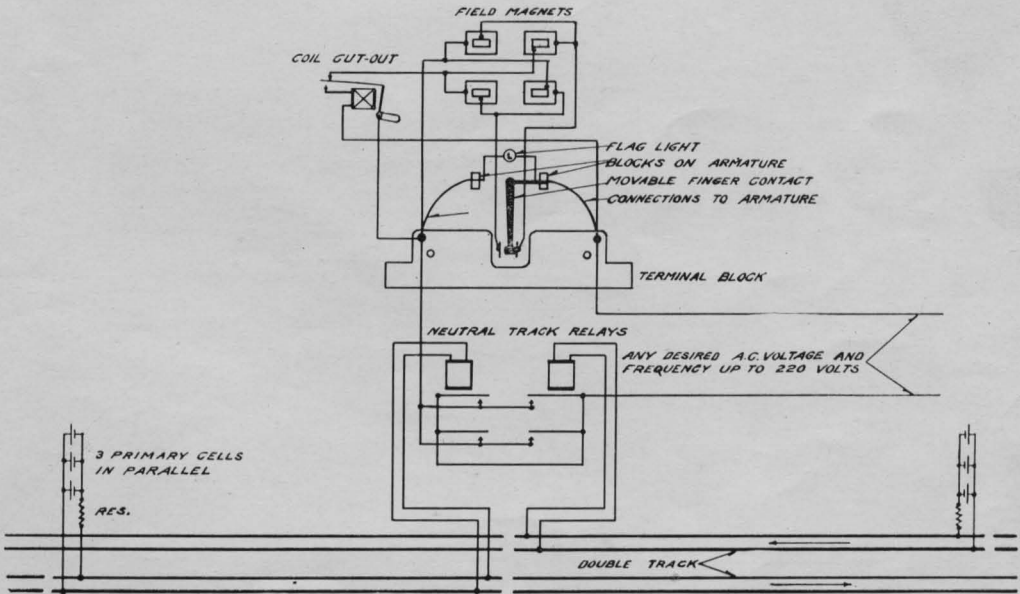

Circuit No. 418. Alternating Current installation of Magnetic Flagman on double track steam line. Signal controlled by D.C. track circuits.

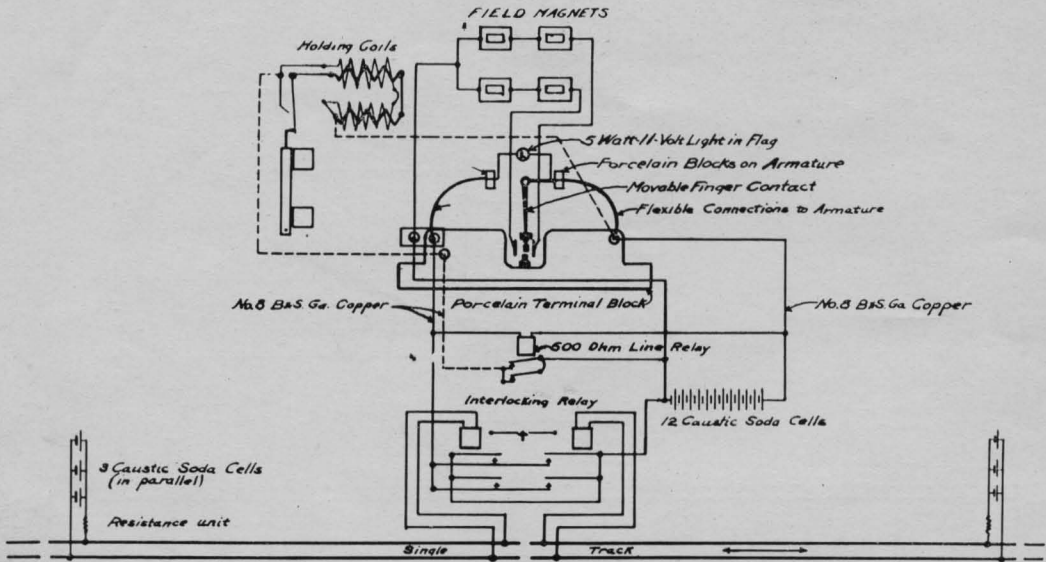

Circuit No. 414. 8-volt D.C. (Caustic Soda Battery) installation of "Three Position" Magnetic Flagman on single track steam line. Traffic in both directions. Signal controlled by D.C. track circuits.

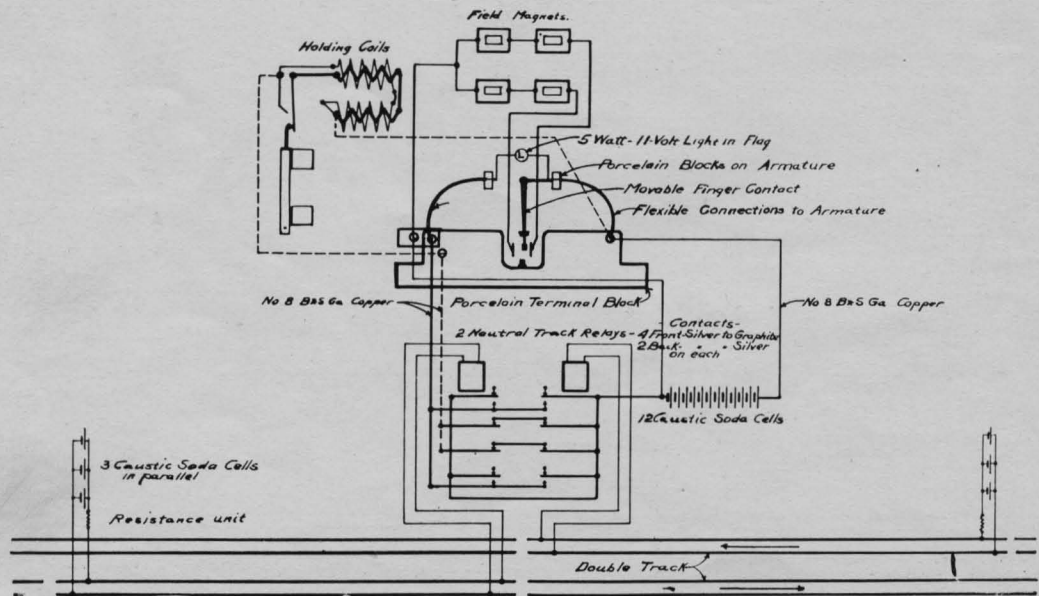

Circuit No. 413. 8-volt D.C. (Caustic Soda Battery) installation of "Three Position" Magnetic Flagman on double track steam line. Signal controlled by D.C. track circuits.

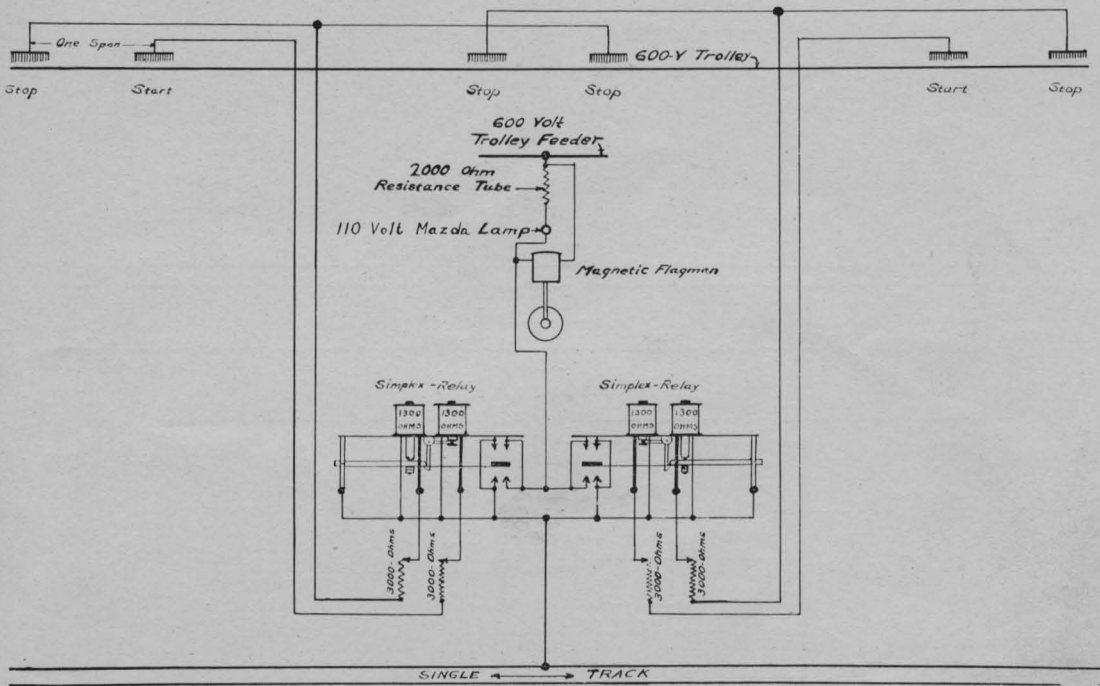

Circuit No. 409. 600-Volt D.C. Trolley Operation of Magnetic Flagman. Trolley Brush Contact Control. For Single Track Electric Road.

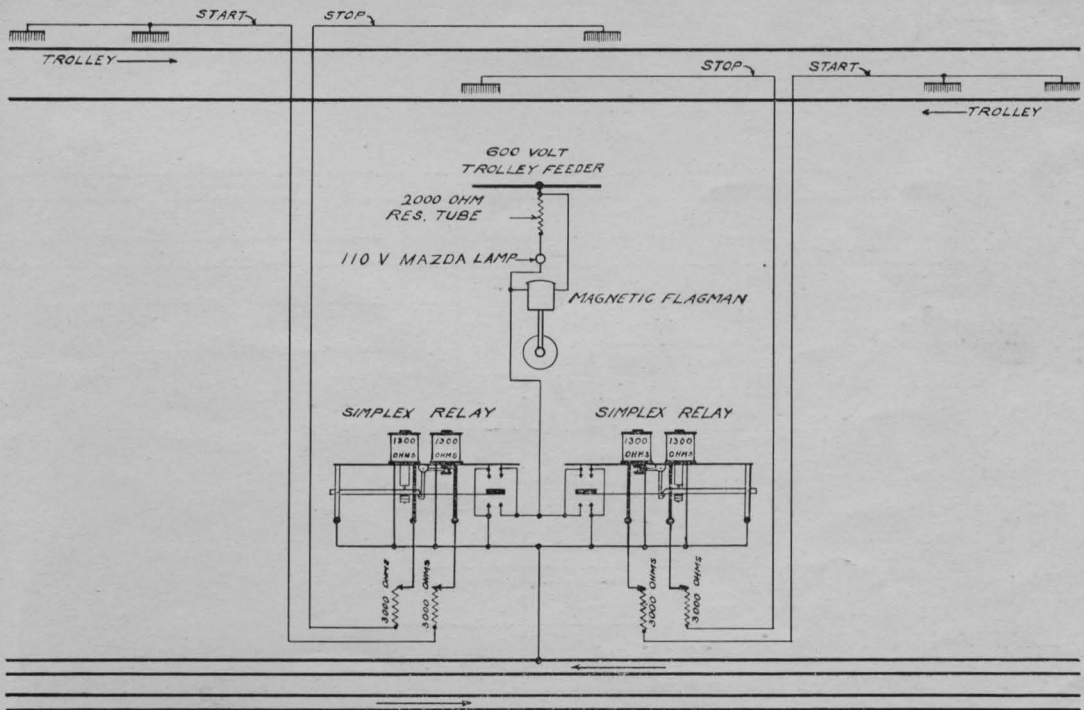

Circuit No. 415. 600-Volt D.C. Trolley Operation of Magnetic Flagman. Trolley Brush Control. For Double Track Electric Road.



**NORMALLY CLOSED**

**A' AND A<sup>2</sup> DIRECTIONAL TRACK INSTRUMENTS**  
**B NON-DIRECTIONAL TRACK INSTRUMENT**

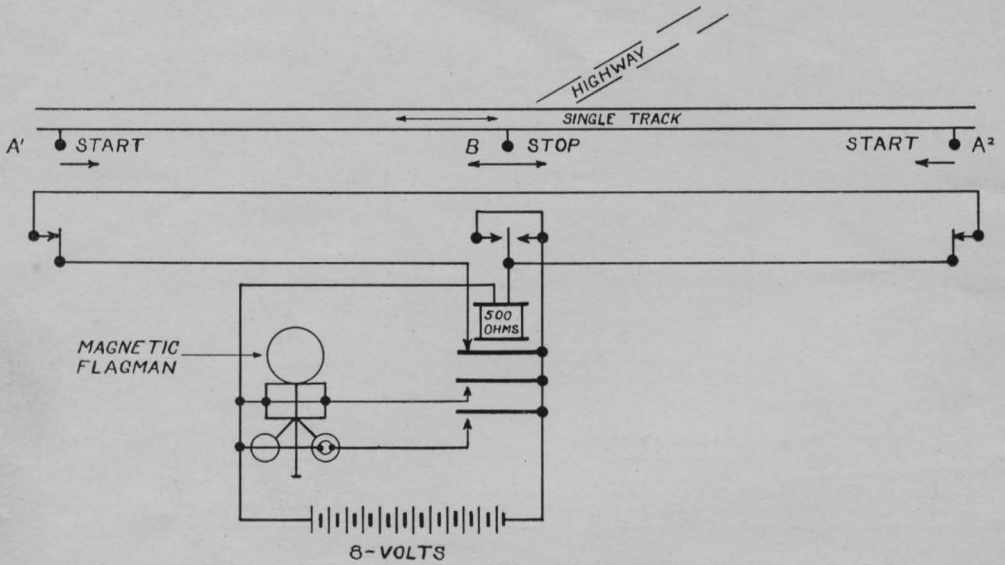

*Circuit No. 451. 8-Volt D.C. Battery Operation of Magnetic Flagman. Directional Track Instrument Control. Single Track Steam or Electric Railroad.*

**NORMALLY CLOSED CIRCUIT**

**A AND B NON-DIRECTIONAL TRACK INSTRUMENTS**

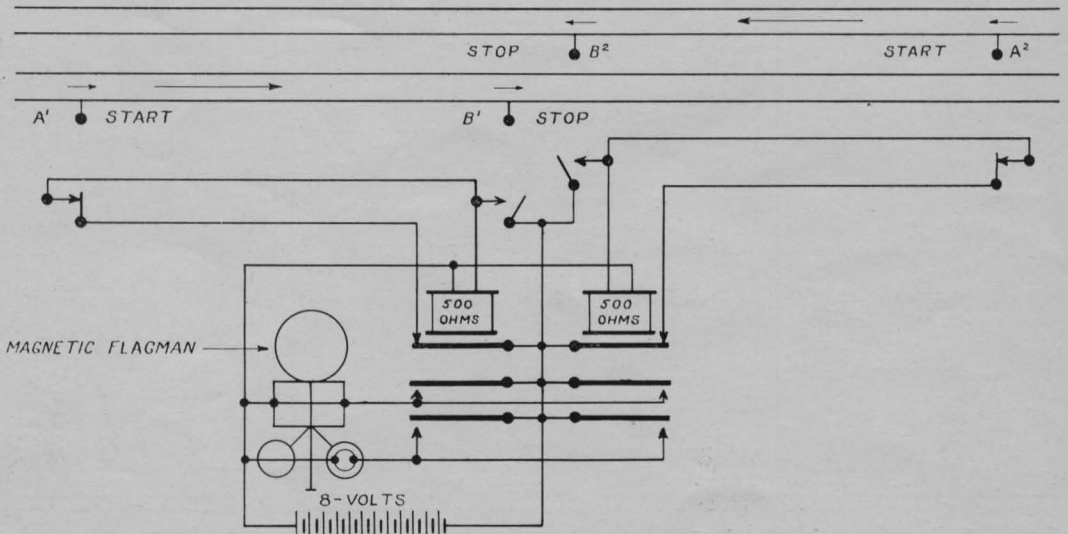

*Circuit No. 455. 8-Volt D.C. Battery Operation of Magnetic Flagman. Non-Directional Track Instrument Control. Double Track Steam or Electric Railroad.*

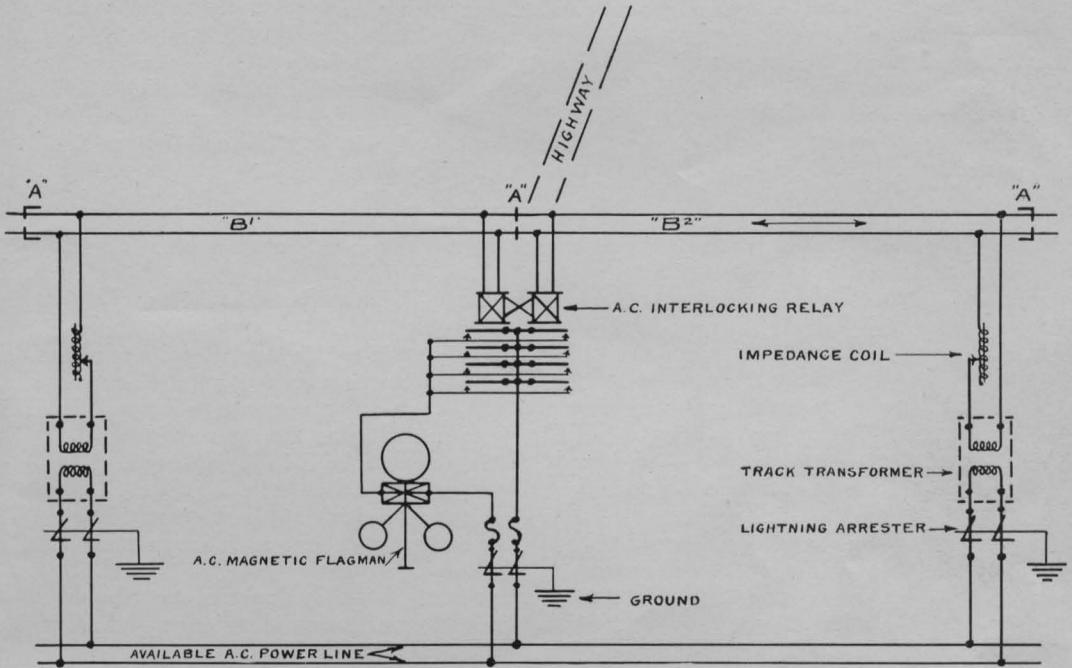

"A" INSULATED RAIL JOINTS  
 "B1" "B2" BONDED TRACK SECTIONS - APPROX. 1000' EA.

Circuit No. 465. Alternating Current Operation of Magnetic Flagman. A.C. Track Circuit Control. Single Track Steam Road—Traffic in Either Direction.

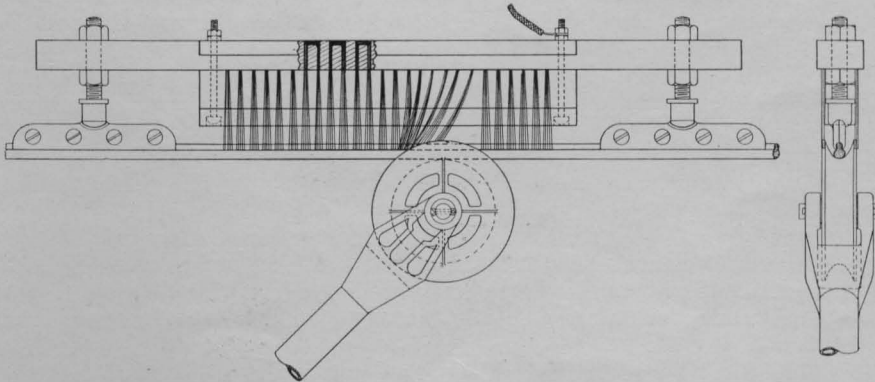

No. 320 Trolley Brush Contact.

## Installation and Maintenance Instructions for All Types of Magnetic Flagmen

1. *Wiring.* See Wiring Diagrams in our Catalog C.
2. *Position of Flagman Mechanism.* Set machine on bracket so that movable finger contact diamond rests equally on either side of stationary diamond mounted on porcelain terminal board. If necessary use set screws in base to level machine if bracket is not horizontal. This adjustment to be made bearing in mind additional weight of workman on bracket. *DO NOT set by bending or changing position of movable finger contact.* Further test adjustment to see that at minimum voltage the armature will pull over and Flagman start on both sets of magnets.

### Maintenance

1. No. 48014-B-3 MOVABLE FINGER CONTACT. This is interchangeable. Do not bend or otherwise adjust.
  2. No. 48012-B. MOVABLE FINGER SPRING. The tension of each leg of this spring against movable finger contact should be equal.
  3. No. 48065-A. STATIONARY CONTACTS. Maintain sufficient tension by adjustment screw on stationary contact bracket No. 48063 to provide for good electrical contact between movable and stationary contacts. Too much pressure will result in unnecessary friction and wear. On all Flagmen operating on less than 220-volt the openings between movable and stationary contacts should be  $3/32''$ . On above 220-volt the openings between movable and stationary contacts should be  $3/16''$ .
  4. When renewing contacts after life of same has passed replace both stationary and movable contacts. Do not use old movable contact with new stationary contacts, as undue wear on the latter will result.
  5. No. 48012-A MOVABLE FINGER CONTACT PIN. Movable finger contact should pivot freely. Its pin must be kept free of corrosion or accumulated dirt and oil. Cotter holding pin in movable finger should be spread to avoid pin falling out.
  6. No. 48062 CONTACT DIAMOND GUIDE AND DIAMOND GUIDE at bottom of movable finger contact are case hardened, and must not be allowed to get chipped on their sharp edges. If properly maintained there should be no reason for any such trouble.
  7. No. 48007-B-2 MOVABLE FINGER STOP. These stops must be kept parallel to path of diamond on movable finger contact No. 48014-B-3. Where "Out of Order" Mechanism is installed movable finger diamond should make contact with both stops.
  8. No. 48010-R AND L. FLEXIBLE RIBBONS. Keep straight and free of kinks. After long wear check for frizzling and replace when any considerable breakage of strands occurs.
  9. No. 48001-C PORCELAIN TERMINAL BOARD. Two supporting machine screws are slightly loosened when Flagman leaves plant to avoid possible breakage of porcelain in transit. These screws should be tightened (not rigidly) when Flagman is placed in operation. Should this porcelain or Porcelain Bracket Support No. 48001-C-1 become broken replace at once.
  10. No. 488 MAGNETS. Pole pieces of magnets are milled to a radius to fit No. 482 Armature. The clearance between pole pieces and armature must be maintained to  $.010''$ . On all two position direct current Flagmen the distance between edge of armature, when flag is hanging vertical, to edge of pole pieces should be  $5/16''$ . The accuracy of these adjustments materially affects the reliability and efficiency of the Flagman.
  11. No. 48057  $2\frac{1}{2}$ -WATT 8-VOLT EDISON SCREW BASE LAMP. No. 48057-A 5-WATT 8-VOLT EDISON SCREW BASE LAMP. For 8-volt D. C. Flagman. Where No. 48057 is used install with third wire to relay as shown in wiring diagram to avoid possibility of burning out filament of  $2\frac{1}{2}$ -watt lamp. This is not necessary with 5-watt lamp.
- No. 48057-600. We recommend 110-volt 25-watt mill type Mazda for 600-volt Flagman. Light to be in series with 2000-ohm resistance of 160-watt capacity.
- No. 48057-110-VOLT. No. 48057-220-VOLT. For alternating current Flagman.

Recommend 25-watt mill type lamp of suitable voltage. Inspection of lamps is highly important.

12. **GONG MECHANISM.** Bell cover should be removed at least every three months for inspection. Bell Strikers No. 48016 should strike with equal force to obtain maximum volume of sound. No. 48021 Striker Lugs should be inspected as to wearing surface of lugs, which are case hardened. When worn a new wearing surface can be obtained by turning lug quarter turn. Each lug has four wearing faces. No. 48022 Striker Lug Tripper is a case hardened part and should be kept free of dirt or gummed oil. This tripper should be free in its movement. In cold countries oil will gum and we recommend either a small amount of flake graphite or no lubrication at all. No. 48026 Striker Hub Pivot Pin; bell striker assembly must pivot freely. Keep these parts free of gummed oil and dirt. No. 4813 Cap Screw (Bell Gong and Cover); keep gong tight to cover to obtain a clear, audible warning.

### Lubrication

1. No. 48012-A MOVABLE FINGER CONTACT PIN. A small quantity of semaphore oil should be applied occasionally. On new type keep oil in well provided at top of Movable Finger Contact No. 48014-B-3.

2. No. 48014-B-3. MOVABLE FINGER CONTACT. Keep small amount of grease on diamond. Also see No. 1 under lubrication.

3. No. 48065-A STATIONARY CONTACTS. It is not customary to apply any oil. Some users, however, find it advantageous to wipe cold rolled steel contact with cloth having small amount of 3 in 1 oil, leaving a slight film of oil on contact.

4. No. 48062-A CONTACT GUIDE. Keep diamond greased or oiled.

5. No. 48021 STRIKER LUGS. Keep grease on wearing surface of lug.

6. No. 48022 STRIKER TRIPPER. In warm climate a few drops of semaphore oil may be used. Do not oil in cold climates. If necessary use dry flake graphite.

7. No. 48008-R AND L STRIKER HUB. Apply few drops of semaphore oil to bell striker hub bearing every three months.

8. No. 4871 AND No. 4872 BALL BEARINGS. These are packed in grease, and should give two years service before other lubrication is required. After that period a few drops of oil every three months will be sufficient.

### Additional Instructions

If Flagman is equipped with brake use no oil on Brake Assembly except a very slight amount on both studs of Brake Band KC-212. The parts which receive wear are these two studs and the edge of Brake Arms KC-230 R and L. These surfaces should be occasionally inspected and if rough should be smoothed with emery. These wearing surfaces are case hardened.

At no time should the Brake Arms KC-230 R and L be allowed to drag on smooth surface of Brake Band KC-212.

### Alternating Current Flagman

Additional equipment consists of coil cut-out. On this do not use oil. Keep Armature Pin No. 48915 clean and clear of dirt, thus allowing Armature No. 48913 to pivot freely.

Check, that when Flagman is not operating, good electrical contact exists between Contact Finger No. 48920 and Upper Contact Pole No. 48921 so that starting coils will receive current when relay contact is closed. Coil cut-out armature should be free to move so on opening of relay contact, armature will drop away from its pole piece. During operation current for coil cut-out flows through Lower Contact Pole No. 48922 to Contact Finger No. 48920.

The clearance between pole pieces and armature should be .010". The distances between edges of armature and pole pieces are  $\frac{1}{16}$ " at starting coil poles and  $\frac{1}{16}$ " at operating coil poles.

### Three Position Flagman

Due to the increased number of parts in the three position locking mechanism a more careful inspection of wearing surfaces, catches and springs should be given.

Use oil judiciously on wearing surfaces but do not allow oil to gum.

Tension on Lever Arm Spring No. 49117 should be just sufficient to allow Lever Arm No. 49112 to be locked by Intermediate Lever No. 49131.

Occasionally check condition of silver contacts No. 49145 and No. 49146. These should be smooth and in position to afford a good electrical contact when engaged by opening of armature, and should absolutely break circuit when armature is against pole pieces.

Keep Lever Arm Guide No. 49109 on which Lever Arm No. 49112 slides, clean and smooth and with a film of light oil.

### "Out of Order" Mechanism

Indicating Electrical or Mechanical Failure of Flagman.

**INSTALLATION.** This mechanism is shipped mounted to its bracket. In a new installation the bracket should first be attached to pole, and then Flagman be later mounted. In old installations where Flagman is already in place and "OUT OF ORDER" is equipped with auxiliary bracket the latter may be slipped under Flagman by raising same  $\frac{1}{4}$ " to  $\frac{1}{2}$ ", thus avoiding necessity of lowering Flagman from pole or of replacing old bracket of our manufacture.

Follow wiring diagram, noting positive and negative leads as shown. Care should be taken that mechanism be level in two planes, and that auxiliary switch closes contact when "OUT OF ORDER" banner is in concealed position. This is important as this contact allows current to pass through holding coils as well as Flagman. Holding mechanism and armature should function freely without binding. Banner should freely rotate.

Mounted on Armature No. OA-120 is an Adjustable Counterweight No. OA-120-7. This has been set and locked at factory, but is furnished to provide method of applying greater holding power in case there is a tendency of the "OUT OF ORDER" banner to drop when Flagman starts on low voltage. The further the counterweight is from the armature the greater the holding power. If this adjustment is changed be certain to lock with Lock Nut No. OA-120-9.

**MAINTENANCE.** Keep Armature Pivot Pin No. OA-121 clean and polished, as well as Armature Trunnion No. OA-122. Lower armature core pins are .017" long and upper core pin length is .014". Armature should rest evenly on pole surfaces. Silver Contact No. OA-168, OA-168-1, and OA-168-2 should be maintained smooth and with sufficient pressure to allow good electrical contact.

**INSPECTION AND LUBRICATION.** Regularly test "OUT OF ORDER" for mechanical and electrical failure of Flagman. Inspect armature by removing Cover Plate No. OA-105. Inspect and clean toggle mechanism by removing Cover Plate No. OA-104. Apply light semaphore oil to armature trunnion and pin, Releasing Crank No. OA-140 (both bearings), to bearing of Contact Spacer Lever No. OA-156, to four banner support bearings at Nos. OA-185, OA-186, OA-187 and OA-188. Every six months apply few drops of semaphore oil to all toggle mechanism pivots and bearings, and to bearing of Banner Catch No. OA-203 at No. OA-204. Do not attempt to replace "OUT OF ORDER" banner to concealed position while relay contact is closed.

### General

The degree of service obtained from the Magnetic Flagman is proportional to the care of inspection and upkeep. Therefore we recommend that the Flagman be kept free of dirt or accumulated dust and gummed oil, that the machine doors be kept locked except during inspection, which should unquestionably be regular and frequent. In ordering we suggest that repair parts be specified by name and part number, giving the type and serial number of the Flagman for which they are required.

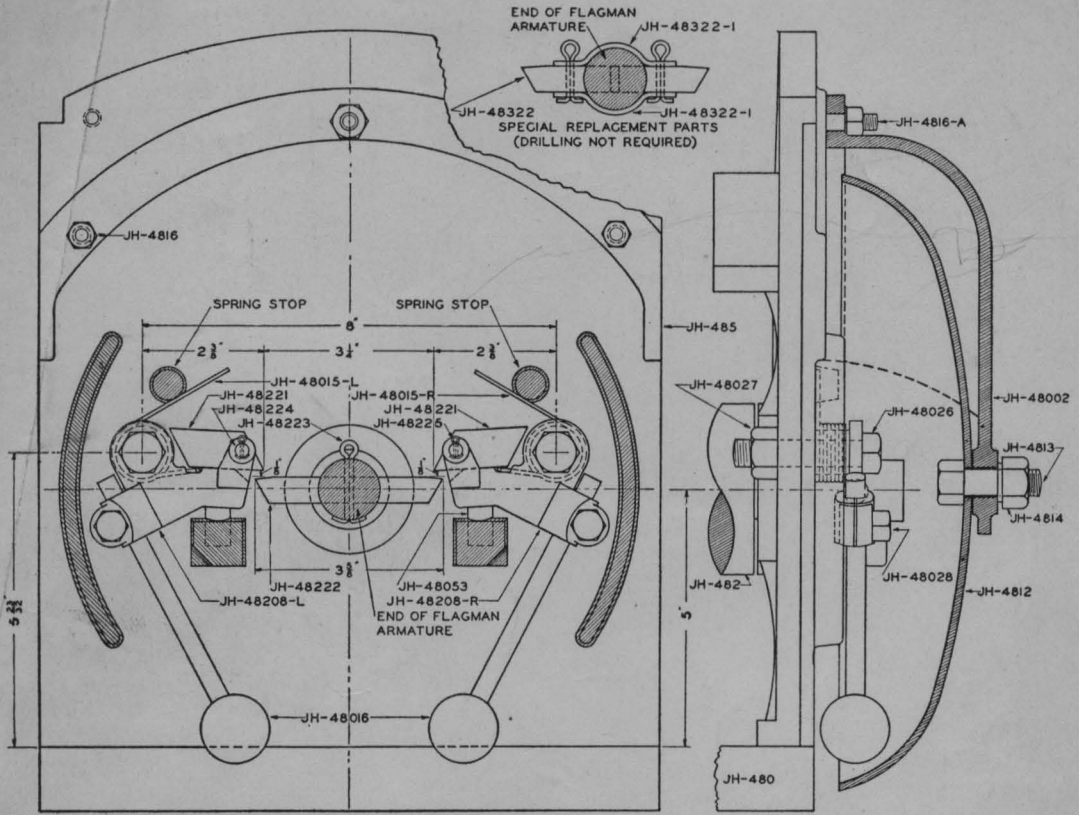

**Type JB Bell Mechanism for Magnetic Wigwag Flagman—Detail Parts**

Order by Piece Number and Description Given in Heavy Face Type Only

Piece	Description	Piece	Description
<b>JH-208</b>	<b>Bell Ringer Parts</b> Consisting of the following: 1 JH-482080-R Striker Hub Assembly—Right Without Hammer 1 JH-482080-L Striker Hub Assembly—Left Without Hammer 1 JH-48322 Stationary Bell Tripper with Cotter Pins and Clamps for Attachment to Old Type Undrilled Wigwag Armature Shafts	<b>JH-48016</b>	<b>Bell Striker</b>
<b>JH-485</b>	<b>Bell End Casting</b>	<b>JH-48026</b>	<b>Cap Screw—<math>\frac{1}{2}</math>"x2 <math>\frac{1}{2}</math>"</b> Hex. Hd. (Cadmium Plated)
<b>JH-4812</b>	<b>Gong—12" Dia.</b>	<b>JH-48027</b>	<b>Hex. Nut—<math>\frac{1}{2}</math>"x13 Th.</b> (Cadmium Plated)
<b>JH-4813</b>	<b>Cap Screw—<math>\frac{1}{2}</math>"x1 <math>\frac{1}{4}</math>"</b> Hex. Hd. (Cadmium Plated) for Fastening Gong to Cover	<b>JH-48028</b>	<b>Cap Screw—<math>\frac{3}{8}</math>"x <math>\frac{3}{4}</math>"</b> Hex. Hd. (Cadmium Plated)
<b>JH-4814</b>	<b>Hex. Nut—<math>\frac{1}{2}</math>"x13 Th.</b> (Cadmium Plated)	<b>JH-48053</b>	<b>Rubber Buffer—<math>\frac{1}{2}</math>" Round</b>
<b>JH-4816</b>	<b>Cap Screw—<math>\frac{5}{16}</math>"x <math>\frac{3}{4}</math>"</b> Hex. Hd. (Cadmium Plated) for Fastening Bell Cover to End Casting	<b>JH-48208-R</b>	<b>Striker Hub Only, Right</b>
<b>JH-4816-A</b>	<b>Stud Bolt—<math>\frac{5}{16}</math>"x1 <math>\frac{1}{2}</math>"</b> (Cadmium Plated) for Holding Bell Cover to End Casting	<b>JH-482080-R</b>	<b>Striker Hub Assembly, R.H.</b> Including Striker Hub, Pawl, Pivot Pin and Cotters—Without Bell Hammer
<b>JH-4816-B</b>	<b>Hex. Nut—<math>\frac{5}{16}</math>"x18 Th.</b> (Cadmium Plated)	<b>JH-48208-L</b>	<b>Striker Hub Only, Left</b>
<b>JH-48002</b>	<b>Bell Cover Casting</b>	<b>JH-482080-L</b>	<b>Striker Hub Assembly, L.H.</b> Including Striker Hub, Pawl, Pivot Pin and Cotters—Without Bell Hammer
<b>JH-48015-R</b>	<b>Bell Ringer Spring—Right</b>	<b>JH-48221</b>	<b>Striker Hub Pawl</b>
<b>JH-48015-L</b>	<b>Bell Ringer Spring—Left</b>	<b>JH-48222</b>	<b>Stationary Bell Tripper</b>
		<b>JH-48223</b>	<b>Cotter—<math>\frac{5}{32}</math>"x1 <math>\frac{1}{2}</math>"</b>
		<b>JH-48224</b>	<b>Pivot Pin</b> For Striker Hub Pawl
		<b>JH-48225</b>	<b>Cotter—<math>\frac{1}{16}</math>"x <math>\frac{1}{2}</math>"</b>
		<b>JH-48322</b>	<b>Stationary Bell Tripper</b> With Cotter Pins and Clamps for Use on Old Type Wigwag Armature Shafts
		<b>JH-48322-1</b>	<b>Bell Tripper Clamp</b>

