

UNION SWITCH & SIGNAL CO.

TABLE OF CONTENTS

SECTION B

STYLE "T-2" SMASHBOARD SIGNALS

| | PLATE |
|--|---------------|
| GENERAL INFORMATION FOR STYLE "T-2" SMASHBOARD SIGNALS..... | Pages 3 and 4 |
| ONE ARM, 2-POSITION 0° to 85° L. H. L. Q. STYLE "T-2" SMASHBOARD SIGNAL..... | B-1500 |
| ONE ARM, 2-POSITION 0° to 90° L. H. U. Q. D. C. L. V. STYLE "T-2" SMASHBOARD SIGNAL..... | B-1505 |
| STYLE "T-2" MECHANISM WITH CASE, BEARING (FOR 5" AND 6" PIPE) AND HAND OPERATING MECHANISM.. | B-1510 |
| STYLE "T-2" D.C. L.V. MECHANISM FOR SMASHBOARD SIGNALS..... | B-1515 |
| D.C. L.V. MOTOR (10 VOLTS) WITH SPECIAL SLOT..... | B-1525 |
| FRAME, PLATES, GEARS AND PINS..... | B-1530 |
| CIRCUIT CONTROLLER..... | B-1535 |
| HAND CRANK OPERATING MECHANISM FOR STYLE "T-2" SMASHBOARD SIGNAL..... | B-1540 |

UNION SWITCH & SIGNAL CO.

GENERAL INFORMATION FOR STYLE "T-2"
SMASHBOARD SIGNALS

Union "T-2" Smashboard Signals can be supplied for either upper or lower quadrant operation of the smashboard. The smashboard is motor-driven to both the clear and danger positions, thus insuring that the position of the smashboard is in agreement with its lever or track control.

The same "T-2" Motor and Hand Operating Mechanisms are used for both 0°-90° L.H. U.Q. and 0°-85° L.H.L.Q. smashboard signals.

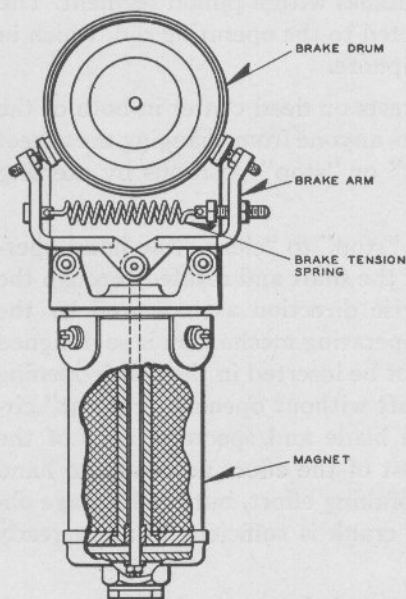
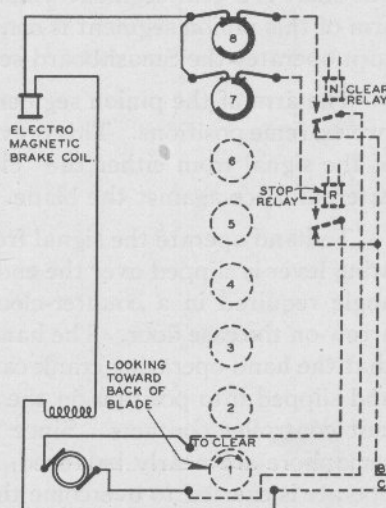

Fig. 1—Electrically Released Friction Brake



NOTE: CIRCUIT CONTROLLER SHAFT MOVES 3 TIMES THE SPEED OF SEMAPHORE IN OPPOSITE DIRECTION. HENCE 90° OF SEMAPHORE IS EQUIVALENT TO 270° OF MOVEMENT OF CIRCUIT CONTROLLER SEGMENT.

Fig. 2—Wiring Diagram of Style "T-2" Smashboard Signal

The difference in quadrant is cared for by locating the stud, to which the "up-and-down" rod connection is made, on the opposite side of the center of the semaphore shaft. The difference in stroke is obtained by proper adjustment of motor control segment on circuit controller.

The "T-2" Motor used in connection with smashboard signals has no ratchet device. Instead of the usual slot, it employs an electromagnet which operates a friction brake. This brake holds the mechan-

ism in any position, in which it may be, when power is off. As shown in Fig. 1, the two cork pads which are fastened to the brake arms are normally held against the brake drum by the brake tension spring. The pressure of these pads upon the brake drum is released when the magnet becomes energized. Since the magnet is in series with the motor, the magnet is energized only as long as the mechanism is being operated. Reference to the wiring diagram, Fig. 2, will show that when the mechanism reaches either the "stop" or "clear" positions, the motor circuit is broken and the brake is automatically applied. Two relays are required for the control of the mechanism, one to be energized for clearing and one for returning to danger.

The "T-2" Mechanism is directly connected to a shaft extending into the case containing the hand operating mechanism. Mounted on this shaft is a gear segment which meshes with a pinion segment. The arm of this pinion segment is connected to the operating rod, which in turn operates the Smashboard semaphore.

The arm of the pinion segment rests on dead center in both of the two extreme positions. This prevents anyone from changing the aspect of the signal from either the "clear" or "stop" positions by exerting external force against the blade.

To hand operate the signal from "stop" to "clear," the hand operating lever is slipped over the end of the shaft and rotated through the angle required in a counter-clockwise direction as indicated by the arrow on the case door. The hand operating mechanism is so designed that the hand operating crank cannot be inserted in the crank opening and slipped into position on the shaft without opening "cut-out" circuit controller contacts. Since the blade and spectacle ends of the semaphore are nearly balanced, most of the effort necessary to hand operate is exerted to overcome the braking effort, but the leverage obtained through the hand operating crank is sufficient to allow ready operation of the smashboard.

As soon as the hand operating crank is removed the "cut-out" contacts automatically close and the mechanism will operate to the position governed by its controlling circuits.