

RIDGELY, ILL.

SD 112 C

INTERLOCKING CIRCUIT PLAN

OFFICE OF ENGINEER-SIGNALS & ELECTRICAL

I.C.G.R.R.

CHICAGO, ILL.

CHECKED:
APPROVED:
ENGINEER-SIGNALS & ELECTRICAL
THIS SUPERSEDES PLAN DATED:
APRIL 4, 1977
SEPT. 16, 1977
FEB. 10, 1981
JULY 5, 1985

95

3

**RIDGELY, ILL. SD 112**  
**RIDGELY INTERLOCKER**  
**TRACK AND LOCATION PLAN**  
 OFFICE OF ENGINEER - SIGNALS & ELECTRICAL  
 I.C.G.R.R. CHICAGO, ILL.

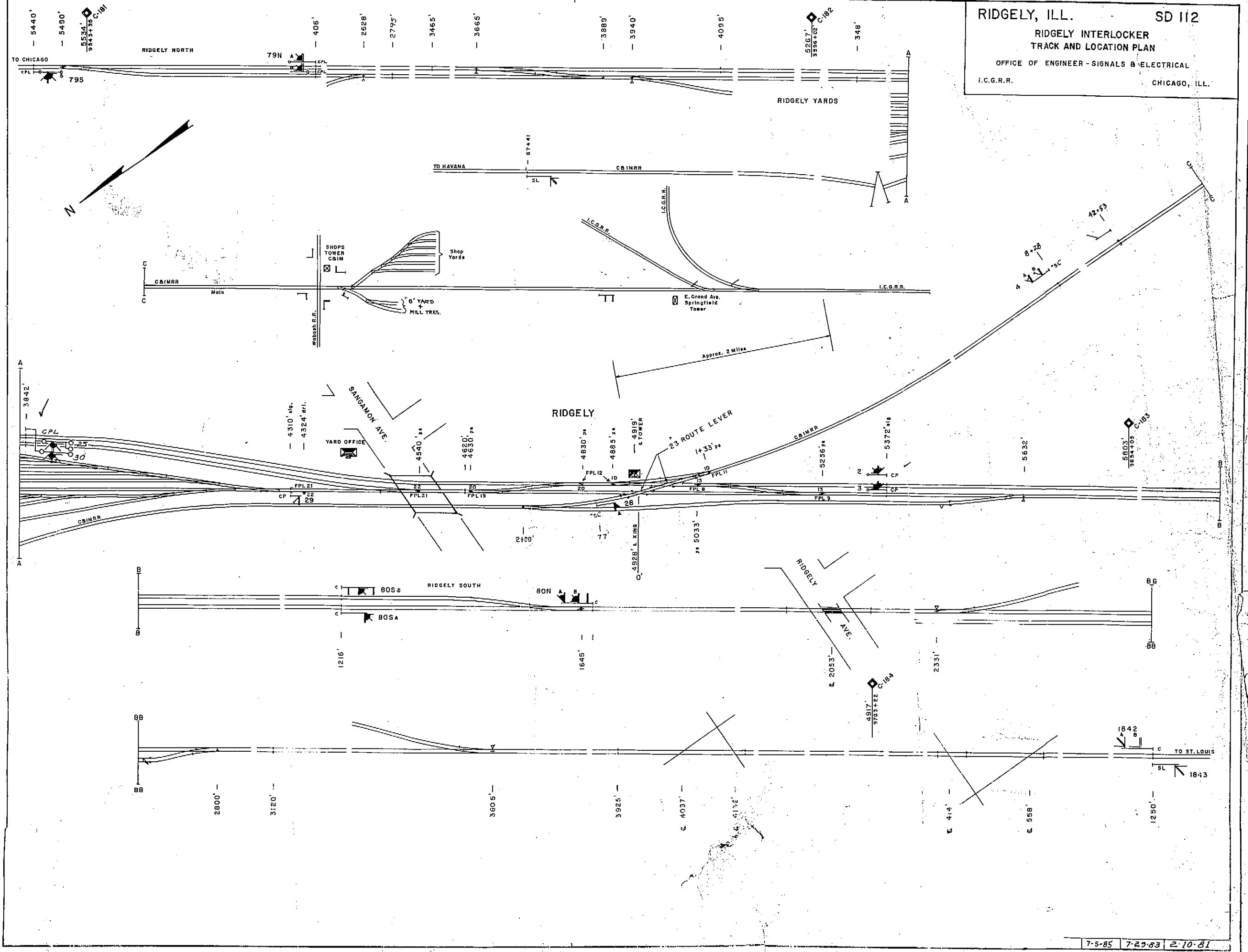

12

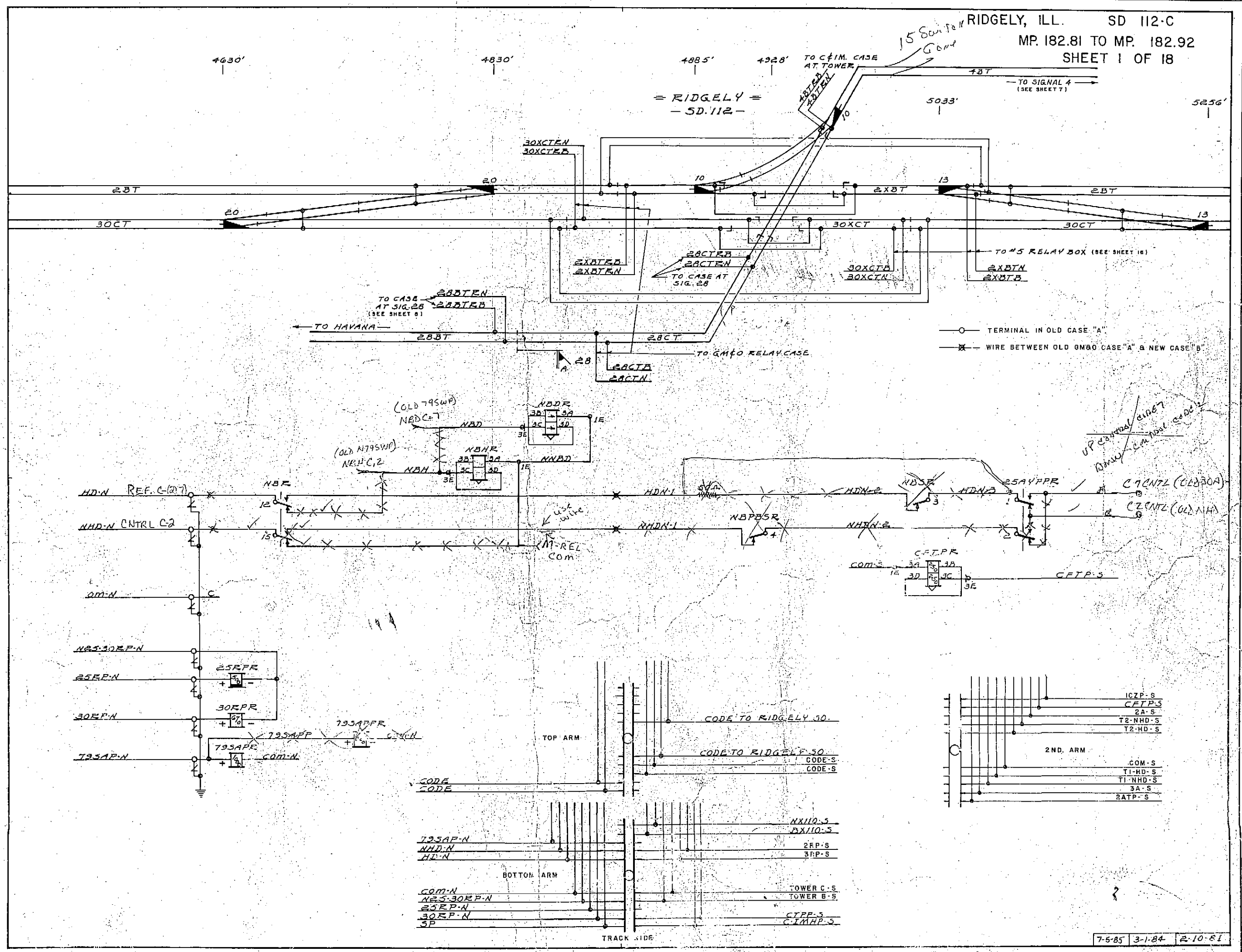

B

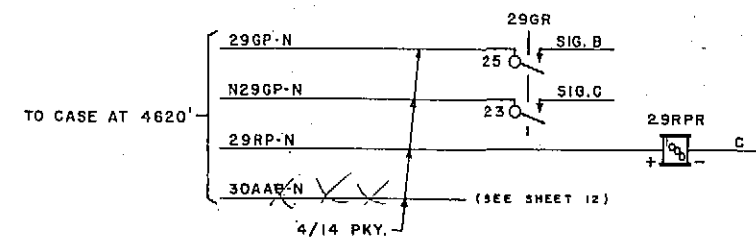
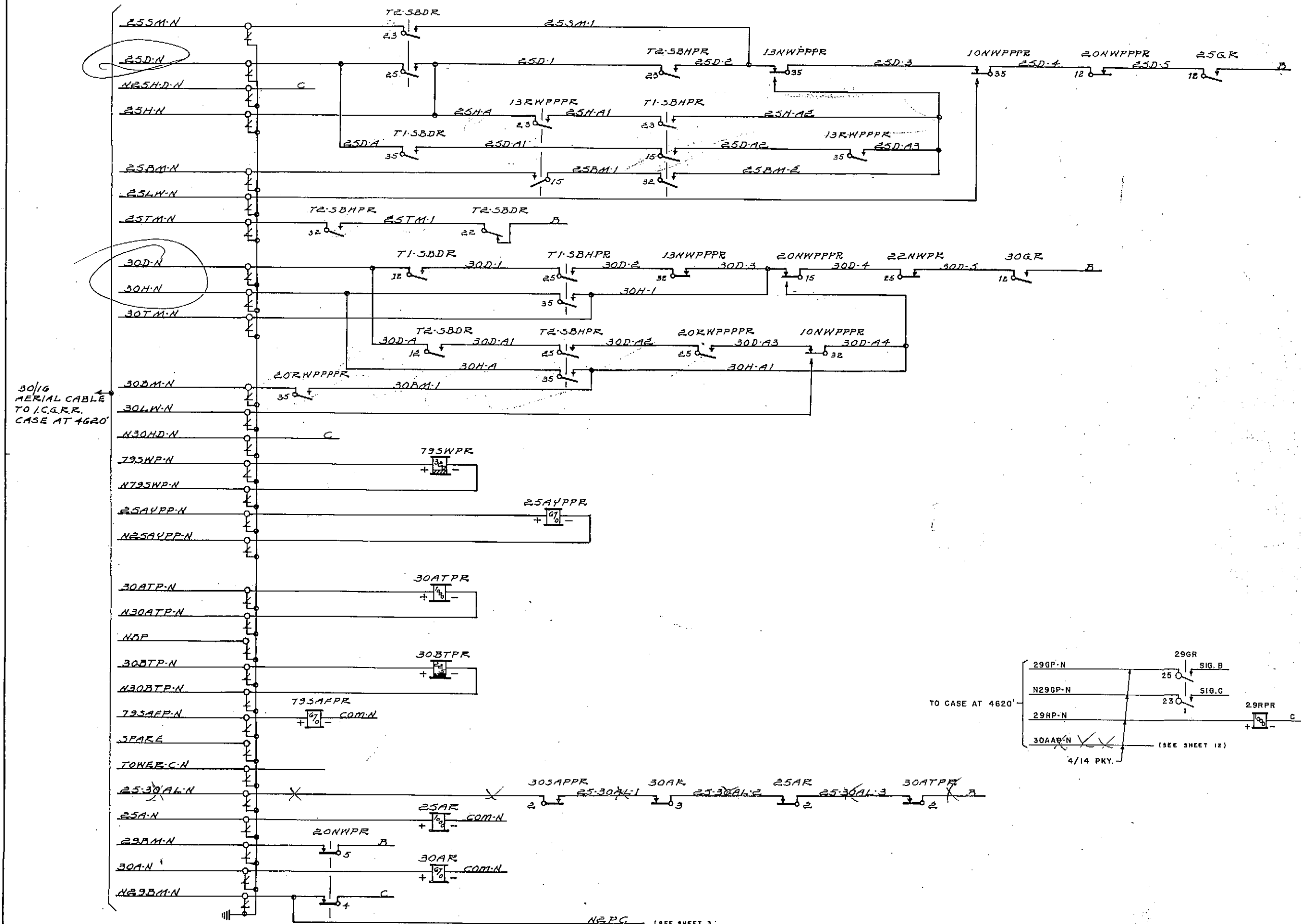

N.E.P.G. (SEE SHEET 3)

14

2515  
DPOW T2 SBR

RIDGELY, ILL SD 112-C  
MP 182.81 TO MP 182.92  
SHEET 3

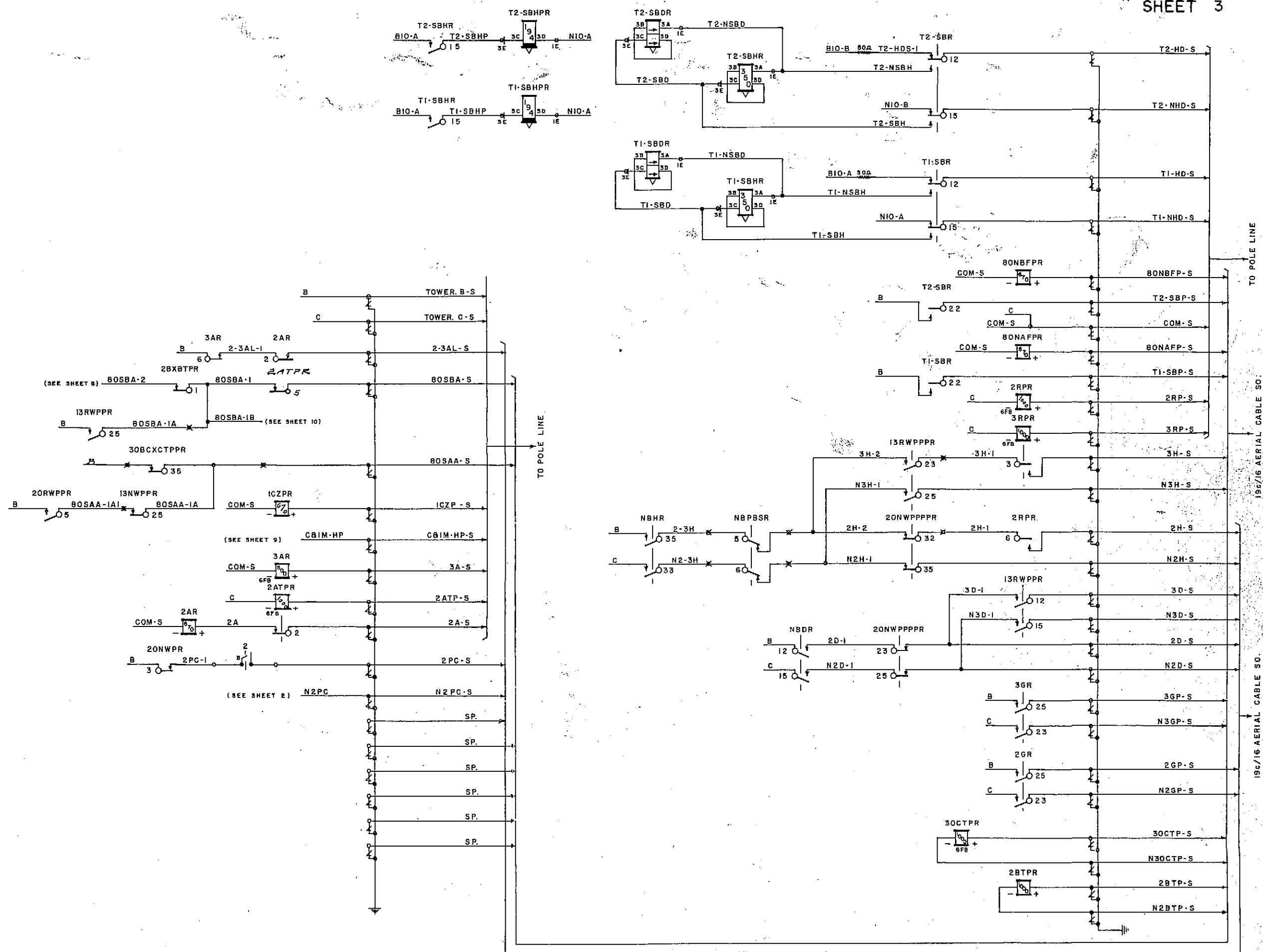



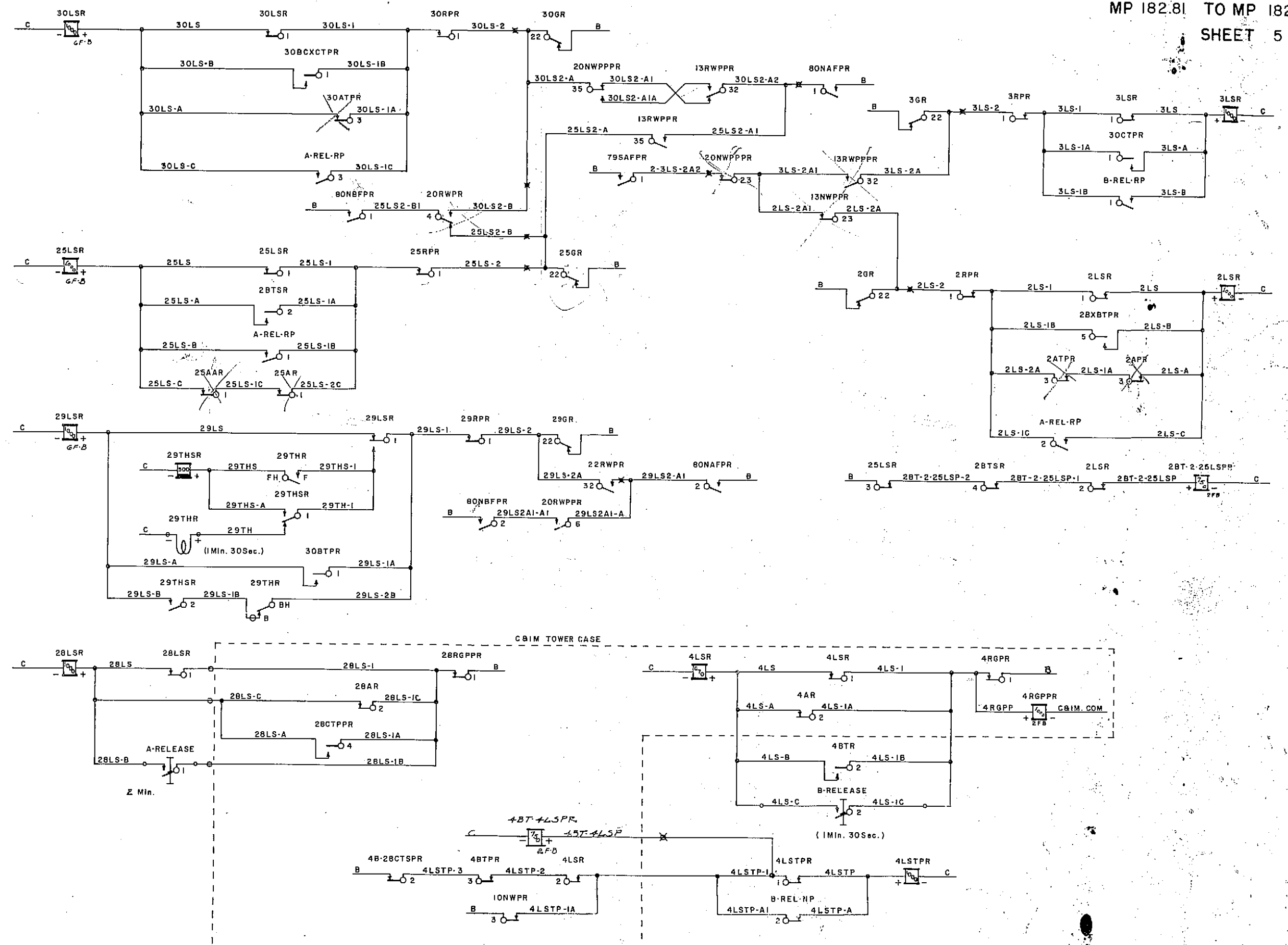

17

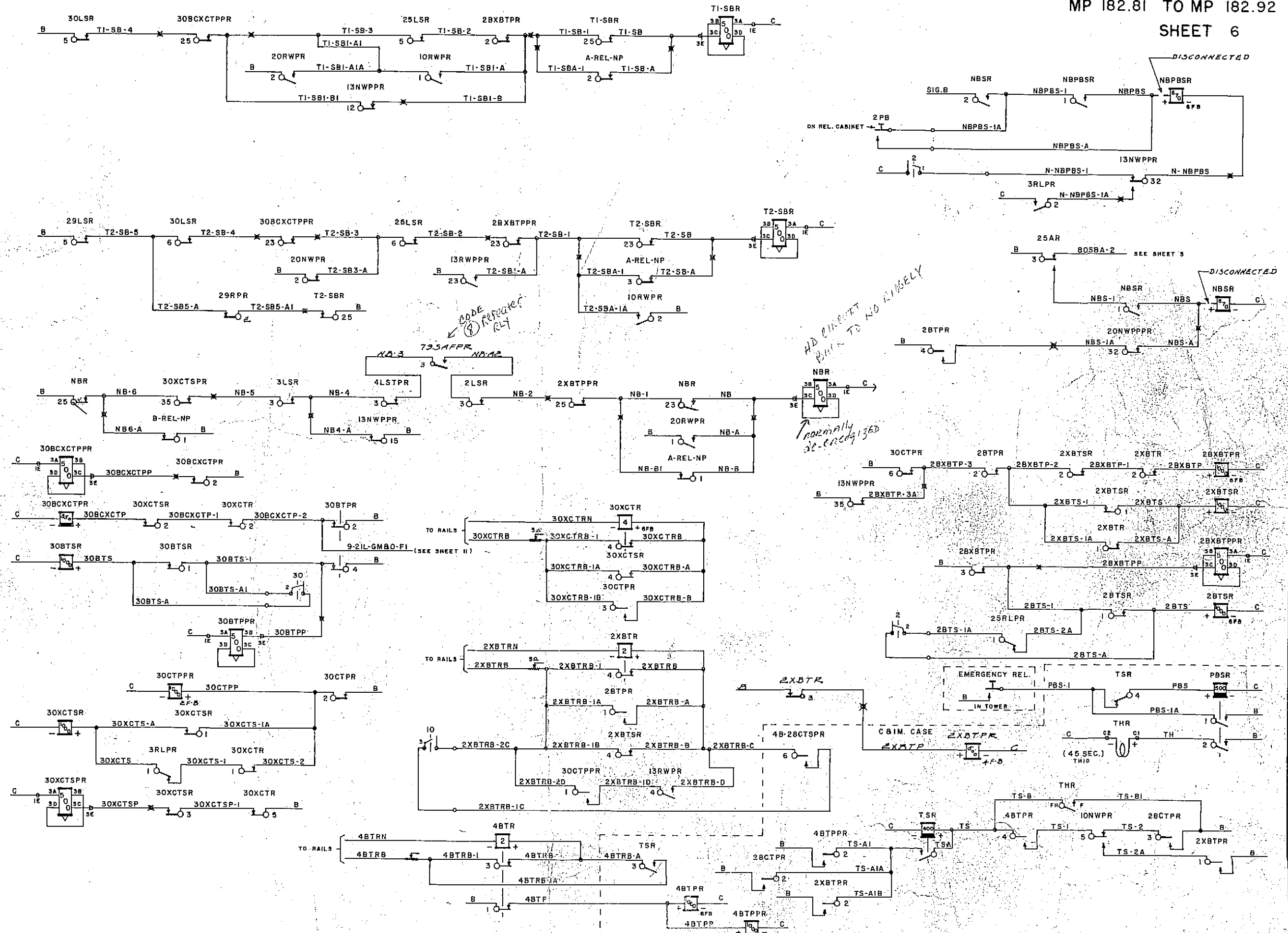



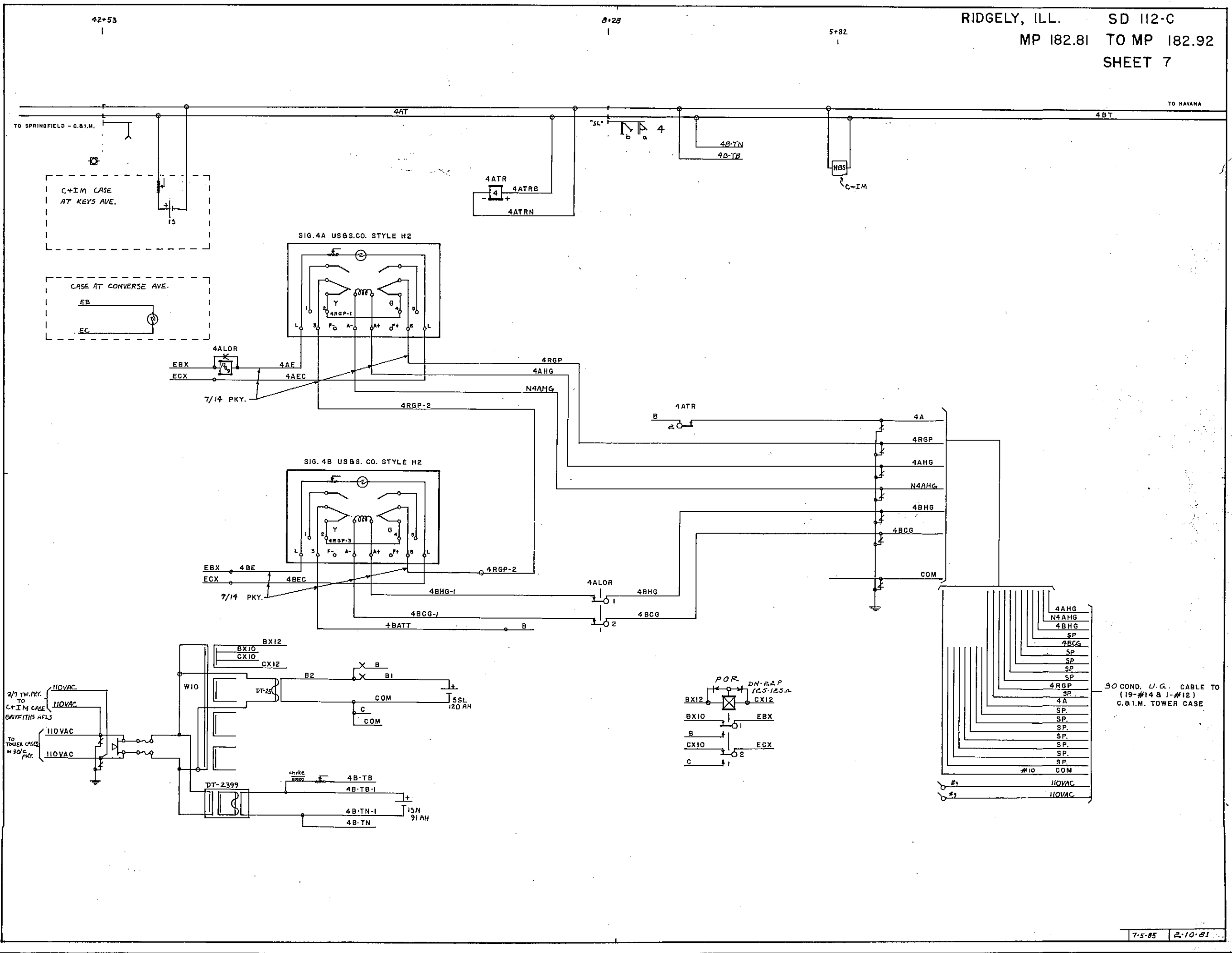

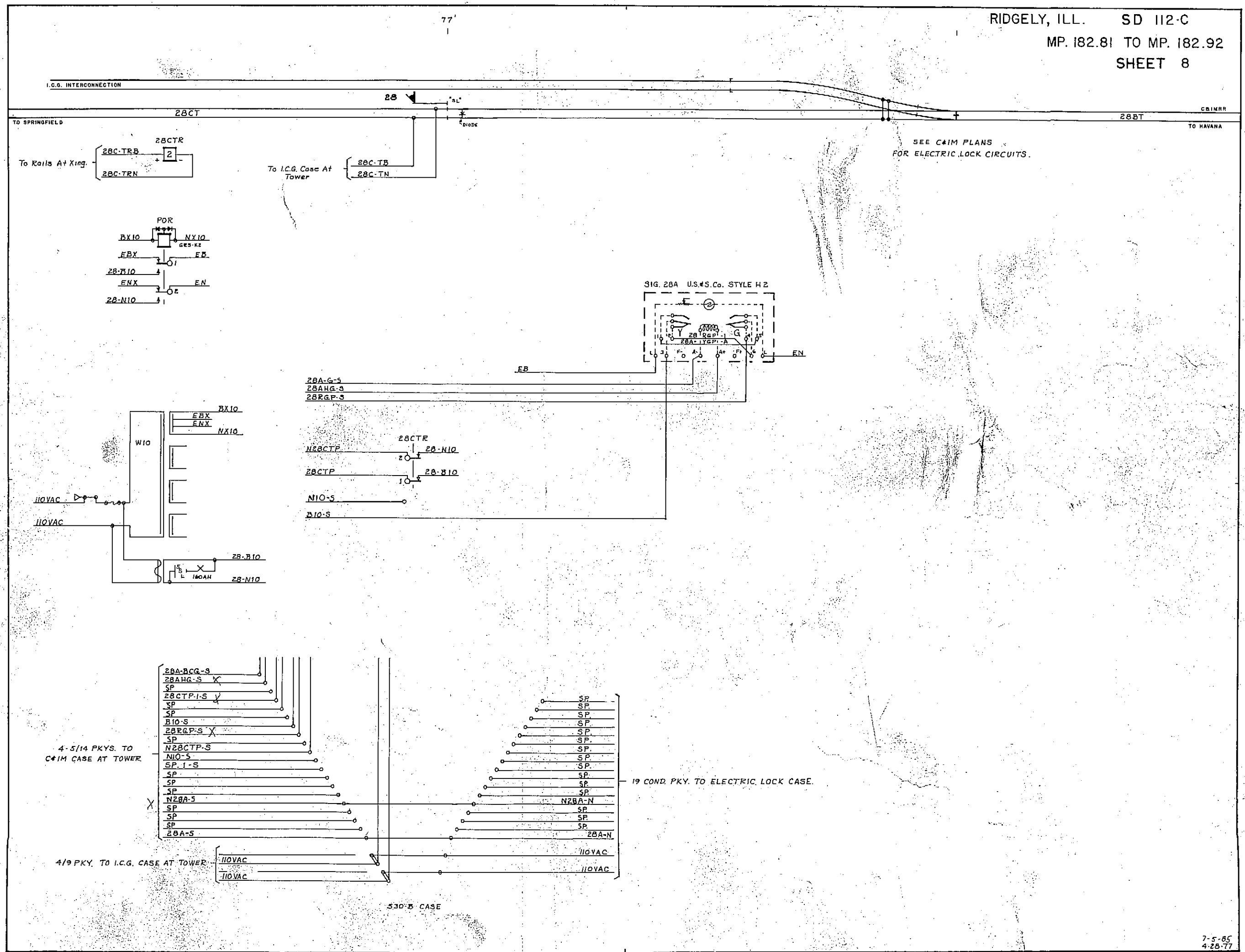

SEE C&IM PLANS  
 FOR ELECTRIC LOCK CIRCUITS.

SIG. 28A U.S.S.Co. STYLE H2

4-5/14 PKYS. TO  
 C&IM CASE AT TOWER

4/9 PKY. TO I.C.G. CASE AT TOWER

19 COND. PKY. TO ELECTRIC LOCK CASE.

530-B CASE



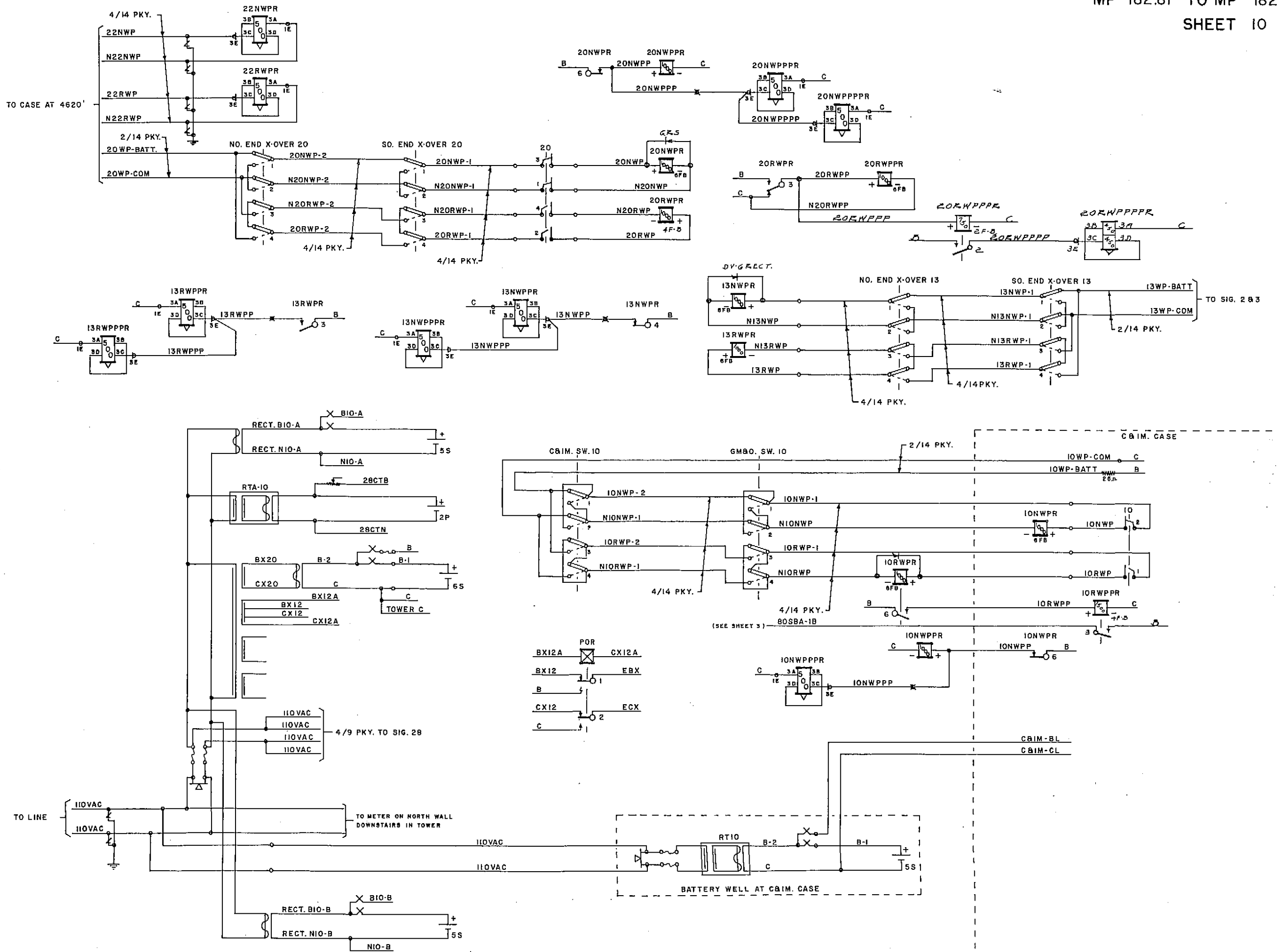

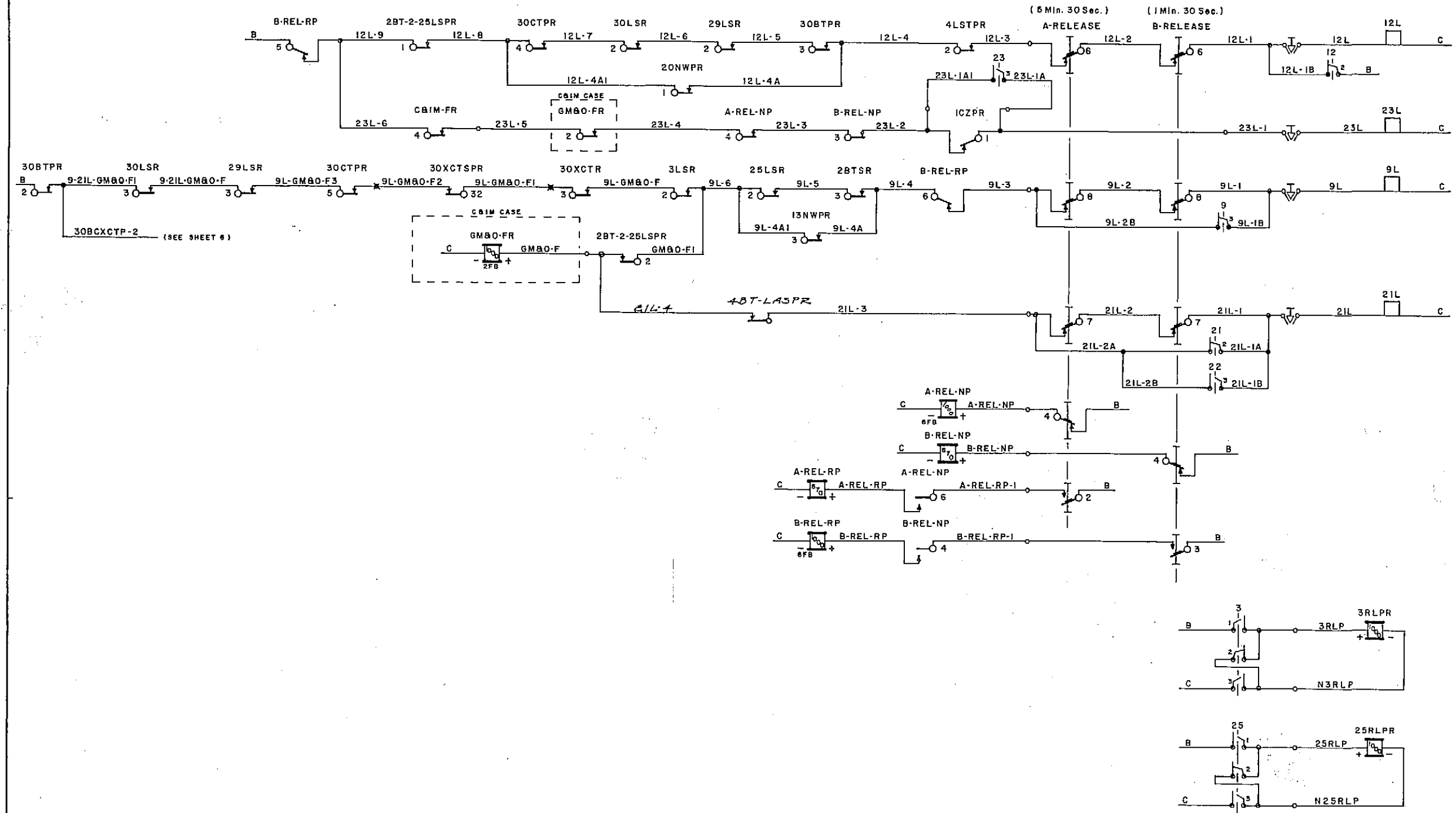

2 Bell  
ECX

INTERLOCKING DIAGRAM LIGHTS

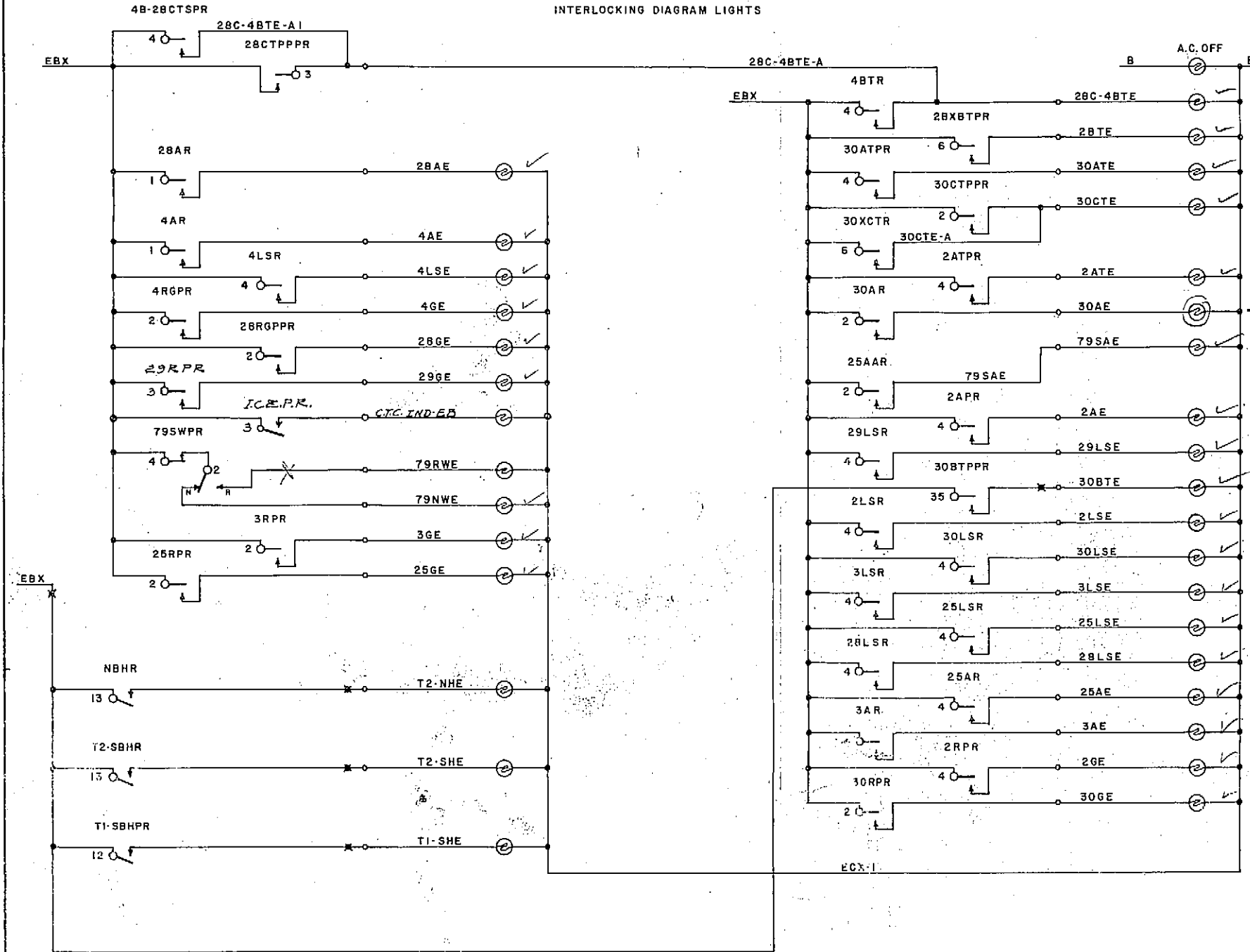

Short app. siding 30 sec

Eq. app. for 20 sec  
East of East Ridgely

Short app. main

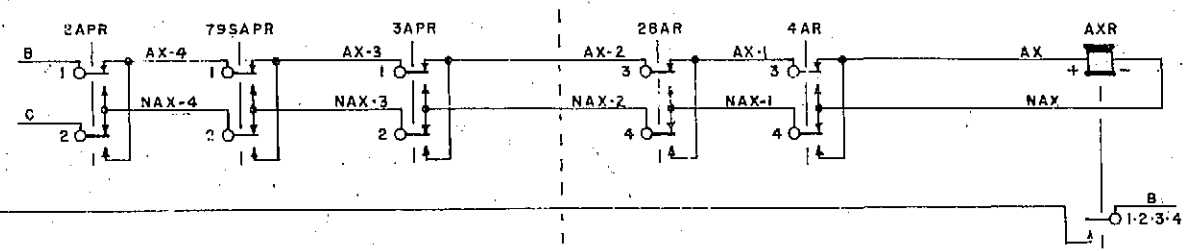
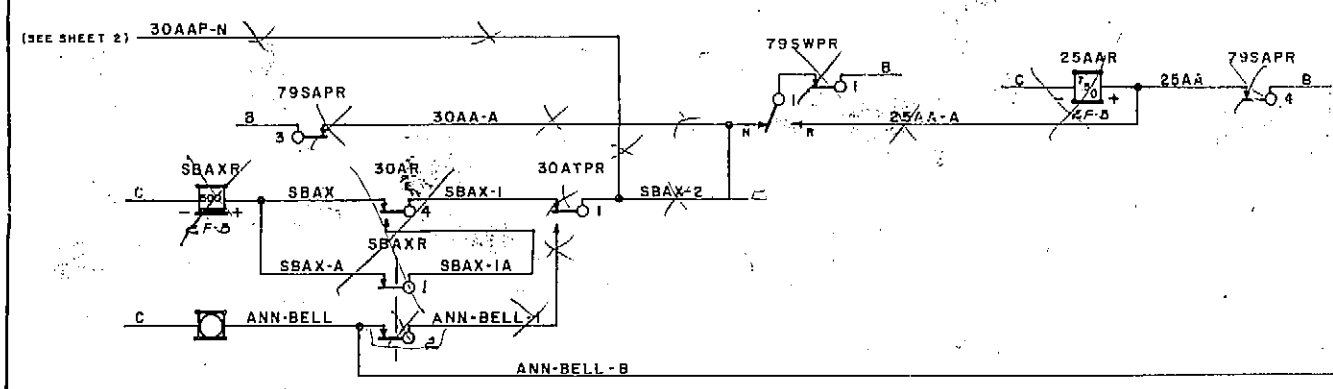
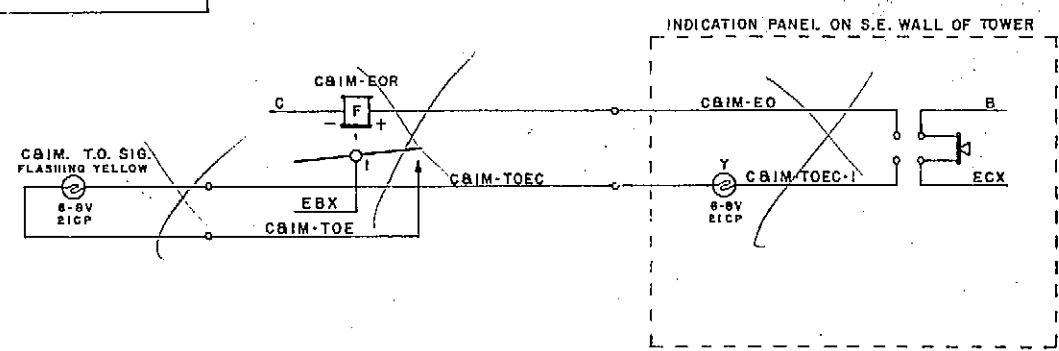

- ⊙ = TERMINAL ON CONVERTER UNIT, PREFIXED WITH C
- ⊕ = TERMINAL ON POWER AND TEST PANEL
- ⊖ = TERMINAL ON CARRIER ASSEMBLY UNIT

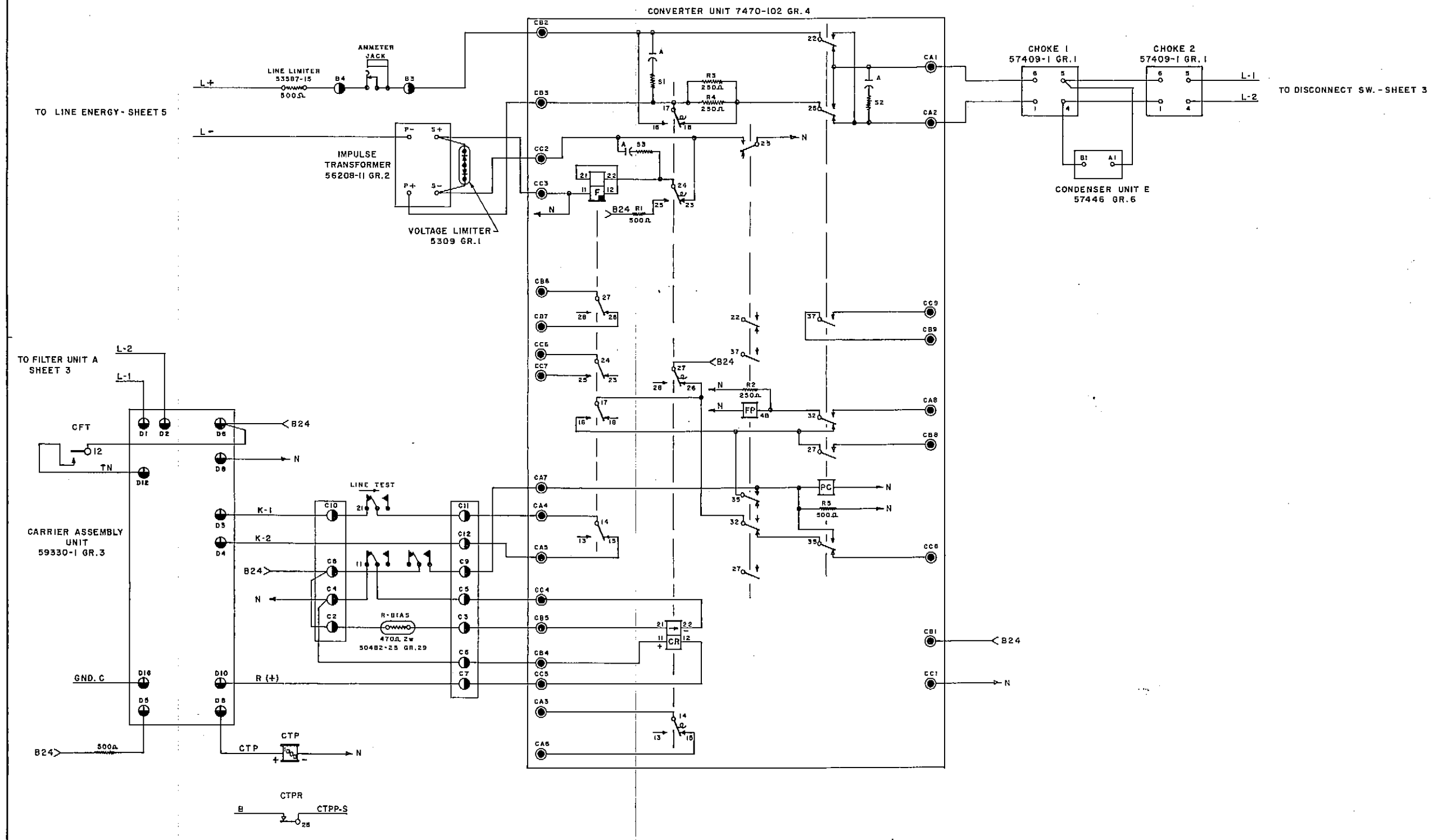

GM&O. TOWER CASE  
RELAY DETAILS

30ATPR		30BTPR		30CTPR		30CTPPR		30XCTR		30BCXCTPR		2ATPR		2BTPR		2BXBTPR		2XBTR		4BTR		<del>4B-20CTSPPR</del>			
1	SBAX-2 30AAP-N	1	29LS-1A 29LS-2B	1	3LS-1A 3LS-1B	1	2XBTRB-2D	1	30XCTS-1	1	30LS-1B 30LS-1A	1		1	2XBTRB-1A 2XBTRB-1B	1	80SBA-1 80SBA-1A	1	2XBTS-1A	1	B	1			
2	B	2	B	2	30CTPP 30XCTS-1A	2	EBX	2	30BCXCTP-2	2	B	2	2A-S	2	2BXBT-3	2	TI-SB-2	2	2BXBT-1	2	4LS-1B 4LS-1C	2	4-25G		
3	30LS-1A 30LS-1B	3	12L-5	3	30XCTRB-1B	3	9L-GM&O-F-1	3	9L-GM&O-F-1	3	3-30G-5	3	2LS-1C 2LS-2A	3	B	3	B	3	2XBTP	3		3			
4	EBX	4	B	4	12L-9 12L-4A1	4	9L-GM&O-F-3	4	30XCTRB-1 30XCTRB-1A	4	N3-30G-5	4	EBX	4	B	4		4	2XBTRB-1 2XBTRB-1A	4	EBX	4			
				5	B	5	B	5	B	5	80SBA	5		5	2LS-1B 2LS-2A	5		5		5		5			
				6	B	6	EBX	6	EBX	6		6		6	EBX	6		6		6		6			
30AR		30BTSR		30XCTSR		25AR		25AAR		2AR		2APR		2BTSR		2XBTSR		3AR		3APR		795APR			
1		1	30BTS-1 30BTS-1A	1	30XCTS-1A 30XCTS-2	1	25LS-2C	1	25LS-1C	1	B	1	B	1	2BTS-1 2BTS-2A	1	2XBTS-A	1	B	1	AX-3	1	AX-4		
2	EBX	2		2	30BCXCTP-1	2	25-30AL-3	2	EBX	2	2-3AL-1	2	C	2	25LS-1A 25LS-1B	2	2XBTP-2	2	80SAA-S	2	NAX-3	2	NAX-4		
3	25-30AL-2	3	3-29-30G-2	3	30XCTSP-1	3	B	3		3		3	2LS-1A	3	9L-5	3		3		3	B	3	B		
4	SBAX-1 SBAX-1A	4	N3-29-30G-2	4	30XCTRB-1A 30XCTRB-1B	4	EBX	4		4		4	EBX	4	2BT-2-25LSP-2	4	2XBTRB-1B 2XBTRB-2C	4	EBX	4		4	B		
														5	2-25G-4	5		5		5		5			
														6	N2-25G-3	6	B	6		6		6			
30LSR		25LSR		29LSR		29LSR		2LSR		3LSR		2BT-2-25LSPR		4LSTPR		NBSR		NBPBSR		SBAXR		CBIM,FR			
1	30LS-1 30LS-1B	1	25LS-1 25LS-1A	1	29LS-1 29LS-2B	1	28LS-1 28LS-1A	1	2LS-1 2LS-1B	1	3LS-1 3LS-1A	1	12L-9	1	4LSTP-1 4LSTP-1A	1	NBS-1	1	NBPBS-1	1	SBAX	1	B		
2	12L-7	2	9L-6 9L-4A1	2	12L-6	2		2	2BT-2-25LSP-1	2	9L-GM&O-F	2	GM&O-F1	2	12L-4	2	SIG-B	2		2	ANN-BELL	2	C		
3	9-21L-GM&O-F1	3	B	3	9-21L-GM&O-F	3	CBIM-F1	3	NB-3	3	NB-5	3		3	NB-4	3	HDN-4	3		3		3			
4	EBX	4	EBX	4	EBX	4	EBX	4	EBX	4	EBX	4		4		4		4	NHDN-2	4		4	23L-6		
5	B	5	TI-SB-3 TI-SB-1A1	5	B	5		5		5		5		5		5		5		5		5			
6	T2-SB-5	6	T2-SB-3 T2-SB-3A	6		6		6		6		6		6		6		6		6		6			
30RPR		29RPR		29RPR		2RPR		3RPR		25RLPR		3RLPR		4RLPPR		A-REL-NP		B-REL-NP		A-REL-RP		B-REL-RP			
1	30LS-2	1	25LS-2	1	29LS-2	1	2LS-2	1	3LS-2	1	2BTS-1A	1	30XCTS 30XCTS-A	1	4-29G-2	1	NB-B	1	NB6-A	1	25LS-1B 25LS-2C	1	3LS-1B		
2	EBX	2	EBX	2	7-2-30	2		2	EBX	2		2	N-NBPBS-1A	2	N4-29G-2	2	TI-SBA-1	2	4LSTP-1A	2	2LS-1C	2			
3		3		3		3		3	3H-1	3	2-25G	3	3-30G-6	3	T2-SBA-1 T2-SBA-1A	3	23L-3	3	30LS-1C	3		3			
4	3G-12	4	2G-10	4	3G-11	4	EBX	4	30G-14	4	N2-25G	4	N3-30G-5	4	23L-4	4	23L-4	4	B-REL-RP-1	4		4			
5		5		5		5	2G-10	5		5		5		5		5		5		5	B	5	B		
6		6		6		6	2H-1	6		6		6		6	A-REL-RP-1	6		6		6		6	9L-4		
795WPR		10RWPPR		10RWPR		10RWPPR		13NWPR		13RWPR		20NWPR		20WPPR		20RWPR		20RWPPR		<del>20RWPPR</del>					
1	B	1		1	TI-SB-A1A	1	B	1	3-30G-3	1	3-30G-3	1	12L-4A1	1	3-30G-1	1	B	1	3-30G-1	1	3-30G-1	1	1-2G	1	
2		2	N4B-CG	2	B	2	BL	2	N3-30G-3	2	N3-30G-3	2	B	2	N3-30G-1	2	B	2	N3-30G-1	2	N3-30G-1	2	2-20RWPPR	2	2-20RWPPR
3		3	2-25G-5	3		3	80SBA-1B	3	9L-4A1	3	B	3	B	3	2-25G-1	3	20RWPP	3	2-25G-1	3	2-25G-1	3		3	
4	EBX	4	N2-25G-4	4	N2-25G-4	4	B	4	B	4	B	4	2XBTRB-ID	4	C	4	N2-25G-1	4		4	N2-25G-1	4		4	
1P	B			5	2-25G-5	5		5	2-25G-7	5	2-25G-7	5	B	5		5		5	80SAA-1A1	5	80SAA-1A1	5		5	
2P	EBX			6	B	6		6	N2-25G-6	6	N2-25G-6	6	B	6		6		6	29LS2A1-A	6	29LS2A1-A	6		6	
				<del>25AYPPR</del>		<del>795APPR</del>		ICZPR		795AFPR		80NAFPR		80NBFP		29THR		29THSR		CBIM-EOR		POR			
				1	HDN	1	23L-1	1	23L-1	1	2-3LS-2A2	1	30LS2-A2	1	25LS2-A1	FH	29THS 29THS-A	1	29TH-1 29THS-1	1	EBX	1	EBX		
				2	NHDN	2	25-30AL	2	4AG-28AG-1	2		2	29LS2-A1 29LS2A1-A	2	29LS2A1-A1	BH	29LS-2B	2	29LS-1B	2	EBX	2	ECX		
				3		3		3	CTC-IND-EB	3	NB	3		3		3		3		3		3			
				4		4		4		4		4		4		4		4		4		4			



26

NEW GM&O TOWER CASE  
RELAY DETAILS

RIDGELY, ILL. SD 112-C  
MP 182.81 TO MP 182.92  
SHEET 15

2		3		4		5		6		7		8		9		10		11		12		13	
T2-SBHPR		T2-SBHR		T2-SBDR				NBDR		NBHR		TI-SBHR		TI-SBDR		TI-SBHPR							
12		12		12	30D			12	B	12		12		12	30D	12	EBX						
15		13	EBX	15				15	C	13	EBX	13		15		15	25D						
22		15	T2-SBHP	22	25TM			22		15	2G	15	TI-SBHP	22		22							
23	25D	32		23	253M			23		32		32		23		23	25H						
25	30D	33		25	25D			25		33	N2-3H	33		25		25	30D						
32	25TM	35		32				32		35	2-3H	35		32		32	250M						
35	30H			35				35						35	25D	35	30H						

CFTPR		T2-SBR		TI-SBR		13RWPPPR		2GR		3GR		4B-CGR		25GR		29GR		NBR		30GR		
12		12	T2-HD-S	12	TI-HD-S		12	25H	12		12		12	N4HG N4HG-A	12	25D	12	HD-N	12	30D		
15		15	T2-NHD-S	15	TI-NHD-S		15	250M	15		15		15		15		15	NHD-N	15			
22		22	T2-SBP-S	22	TI-SBP-S		22		22	2LS-2 2LS-2A	22	3LS-2 3LS-2A	22		22	25LS-2 25LS-2A	22	29LS-2 29LS-2A	22	30LS-2 30LS-2A		
23		23	T2-SB-I T2-SBA-I	23			23	3H-1	23	N2GP-S	23	N3GP-S	23		23		23	N29GP-N	23	NB-I NB-B-I	23	
25		25		25	TI-SB-I TI-SBA-I		25	N3H-S	25	2GP-S	25	3GP-S	25		25		25	29GP-N	25	B	25	
32		32		32			32	3LS-2A	32		32		32		32		32		32		32	
35		35		35			35	25D	35		35		35	4B-G	35		35		35		35	

2BXBTPPR		30BCXCTPPR		30XCTSPR		30BTPPR		13RWPPR		13NWPPR		13NWPPR		10NWPPR		20NWPPR		20NWPPPR		22RWPR		22NWPR	
12		12		12	3-29-30G-3	12		12	3D-S	12	TI-SB1-B1	12		12		12	25D	12		12	3-29-30G	12	3-29-30G
15		15		15	N3-29-30G-2	15		15	N3D-S	15	NB-4A	15		15		15	30D	15		15	N3-29-30G	15	N3-29-30G
22		22		22		22		22		22		22		22		22		22		22		22	
23	T2-SB-2	23	T2-SB-4	23		23		23	B	23	2LS-2A	23		23	N4HG-A	23	2LS-2A1 3LS-2A1	23	2D-I	23		23	
25	NB-2	25	TI-SB-4	25		25		25	80SBA-1A	25	80SAA-1A	25		25		25		25	N2D-I	25		25	30D
32		32		32	9L-GM&O-FI	32		32	30LS2-A2 25LS2-A1	32	N-NBPBS	32	30D	32	30D	32	NBS-1A	32	2H-I	32	29LS-2A	32	
35		35	80SAA-1 80SAA-1A	35	NB-6	35	30BTE	35	25LS2-A 25LS2-B	35	B	35	25D	35	25D	35	30LS-2A 30LS-2B	35	N2H-S	35		35	

10

20NWPPPR  
12  
15  
22  
23  
25  
32  
35 30B1

27

CBIM. TOWER CASE  
RELAY DETAILS

RIDGELY, ILL. SD 112-C  
MP 182.81 TO MP 182.92  
SHEET 16

4BTPR	4BTPPR	28CTPR	28CTPPR	28CTPPPR			
1	1 4B-28CTS-4	1 [ 28CTP-1-N 28CTP-1A	1 CBIM-F1	1			
2	2 [ TS-A1 TS-A1A	2 [ TS-A1A TS-A1B	2	2			
3	3 4LSTP-3	3 TS-2	3 [ 4B-28CTS-3 4B-28CTS-A1	3 [ 28C-4BTE-A 28C-4BTE-A1			
4	4 [ TS-B	4 4PBS-1	4 28LS-1A	4			
5		4 [ 28CTPP 28CTPPP					
6							
4RQPR	4RPR	4LSR	4RLPR	28RQPR	28RQPPR	28RQPPPR	28RLPR
1	1 4LS-2	1 [ 4AG-28AG-2A 4AG-28AG-2A1	1 [ 4LS-1 4LS-2A	1 4AHG	1 [ 28RQPP 28RQPPP	1 B	1 28AHG
2	2 EBX	2	2 4LSTP-2	2 4BHG	2 4AG-28AG-2A1	2 EBX	2
3	3 4RP-1		3	3		3	3
4	4		4 EBX	4 [ 4BG N4AHG.		4	4 28A-G
1P			5 B				
2P			6				
THR	GMBO-FR	IONWPR	IORWPPR	4LSTPR			
1	1 4AG-28AG	1 4ABG-4CH-2	1 B	1 4LSP			
2	2 23L-5	2 28G-2	2	2 12L			
3		3 4LSTP-1A	3	3 NB			
4		4 4ABG	4 B	4			
		5 TS-1					
		6 B					

2XBTPR	4B-28CTSR	4B-28CTSPR	4AR	28AR
1	1 TS-2A	1 4B-28CTS-A1	1 4B-C-1	1 EBX
2	2 TS-A1B	2 28AHG-2	2 4LSTP-3	2 4LS-1A
3	3	3 4ABG-1	3 4B-28CTSPR	3 AX-1
4	4	4 B	4	4 NAX-1
			5	5 29G-13A
			6	6 N29G-13A
4RLPR	28RQPR	28RQPPR	28RQPPPR	28RLPR
1	1 4AHG	1 [ 28RQPP 28RQPPP	1 4AG-1	1 28AHG
2	2 4BHG	2 4AG-28AG-2A1	2 EBX	2
3	3		3	3
4	4 [ 4BG N4AHG.		4	4 28A-G
PBSR	TSR	AXR	4RQPPR	
1	1 PBS-1A	1 TS-A	1 B	
2	2 TH	2 28CTP-A	2 B	
3	3	3 4BTRB-A	3 B	
4	4	4 PBS	4 B	

4BT-4LSPR  
1 21L  
2

12ZPR (COILS DISCONNECTED)  
1 23L  
2 4AG-28AG-4CH-1  
3 CTC Ind.  
4

CIRCUIT BREAKER ADJUSTMENT

CLOSES WITH LEVER REVERSE LATCH HALF DOWN: 2<sup>1</sup>-2<sup>3</sup>-2<sup>5</sup>-2<sup>7</sup>- 3<sup>1</sup>-3<sup>3</sup>- 4<sup>2</sup>-4<sup>4</sup>- 9<sup>1</sup>- 10<sup>1</sup>-10<sup>2</sup>- 12<sup>3</sup>- 15<sup>1</sup>- 20<sup>2</sup>-20<sup>4</sup>- 21<sup>1</sup>- 22<sup>2</sup>- 23<sup>1</sup>-23<sup>3</sup>- 24<sup>1</sup>-24<sup>3</sup>- 25<sup>1</sup>-25<sup>3</sup>-28<sup>2</sup>-28<sup>4</sup>  
 29<sup>1</sup>-29<sup>3</sup>- 30<sup>1</sup>-30<sup>3</sup>-30<sup>7</sup>  
 OPENS WITH LEVER NORMAL LATCH HALF UP: 2<sup>2</sup>-2<sup>4</sup>-2<sup>6</sup>- 4<sup>1</sup>- 9<sup>2</sup>- 10<sup>3</sup>- 12<sup>2</sup>- 15<sup>2</sup>- 20<sup>1</sup>-20<sup>3</sup>- 21<sup>2</sup>- 28<sup>1</sup>- 29<sup>2</sup>-29<sup>4</sup>- 30<sup>2</sup>-30<sup>4</sup>-30<sup>6</sup>  
 OPENS WITH LEVER REVERSE LATCH 1/3 DOWN: 3<sup>2</sup>-4<sup>3</sup>- 24<sup>2</sup>- 25<sup>2</sup>- 28<sup>3</sup>

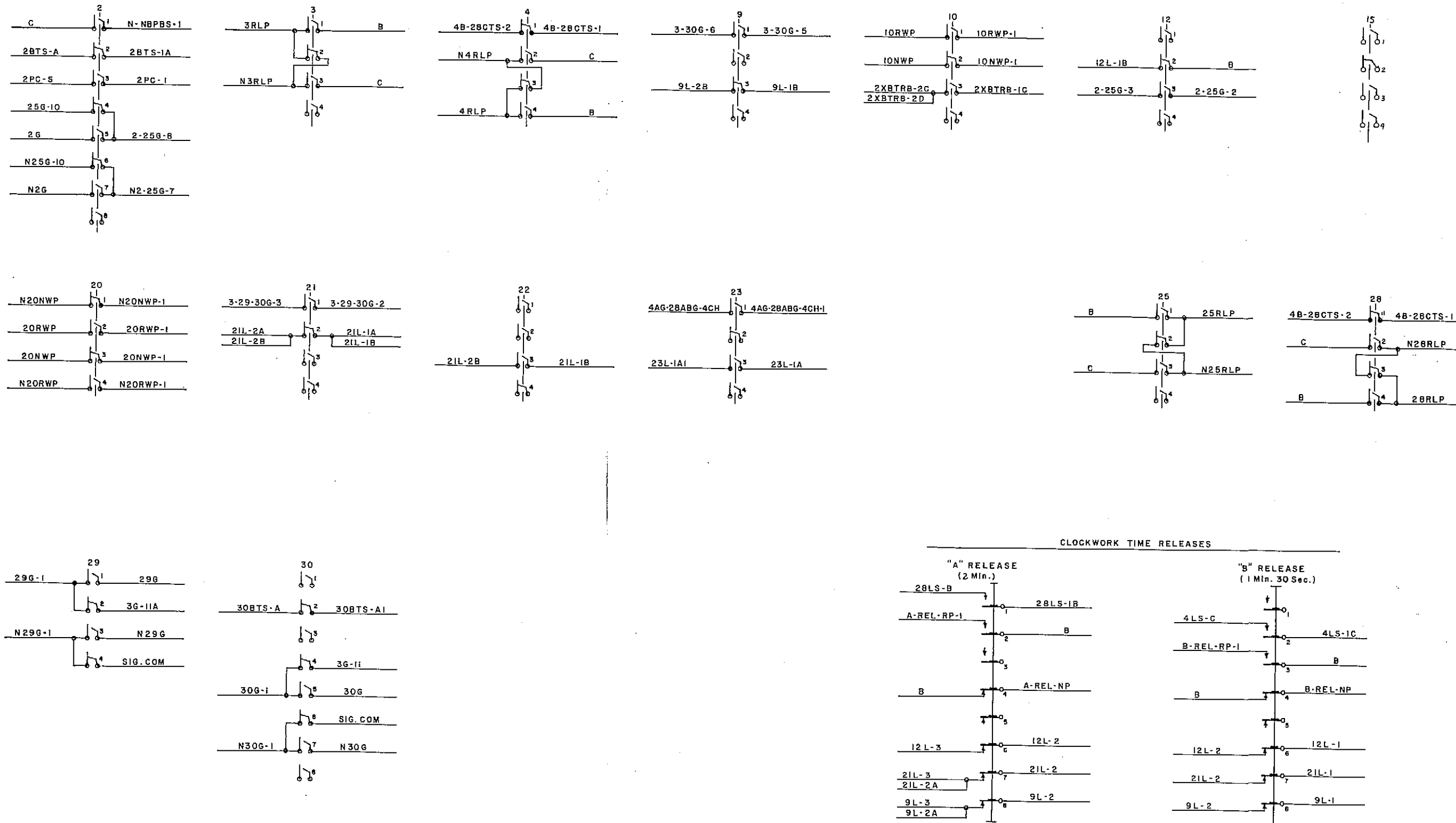

CLOCKWORK TIME RELEASES

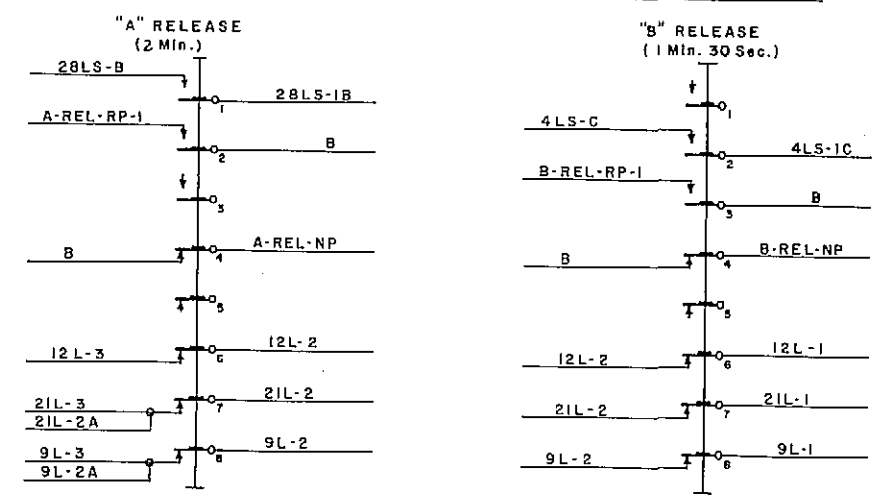

29

# 5 RELAY BOX AT 13 X-OVER

RIDGELY, ILL. SD 112-C  
MP 182.81 TO MP 182.92  
SHEET 18 OF 18

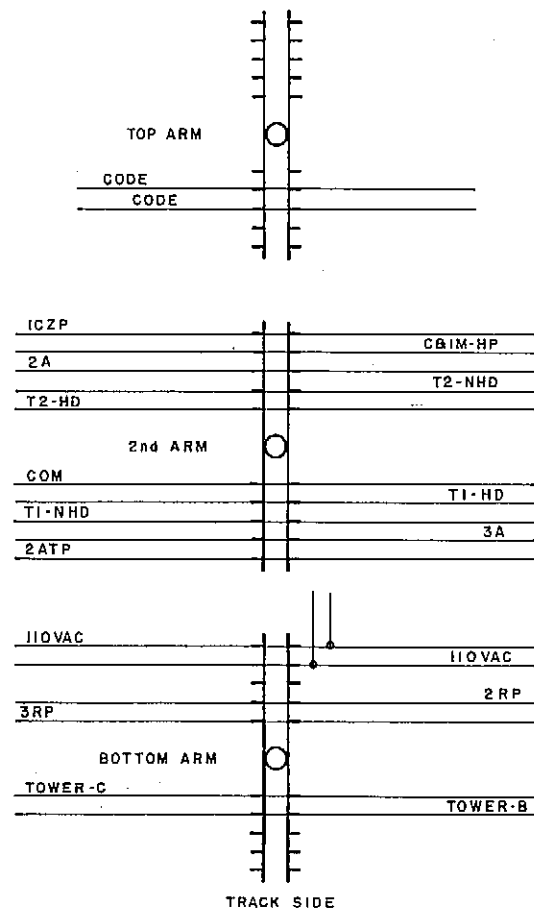
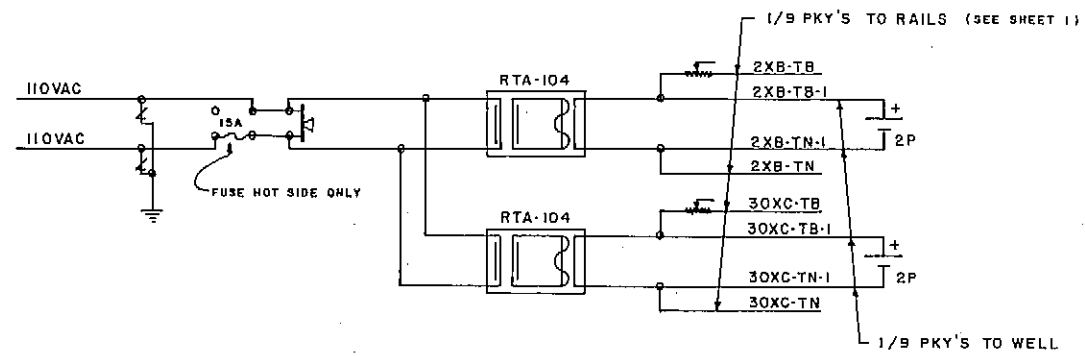

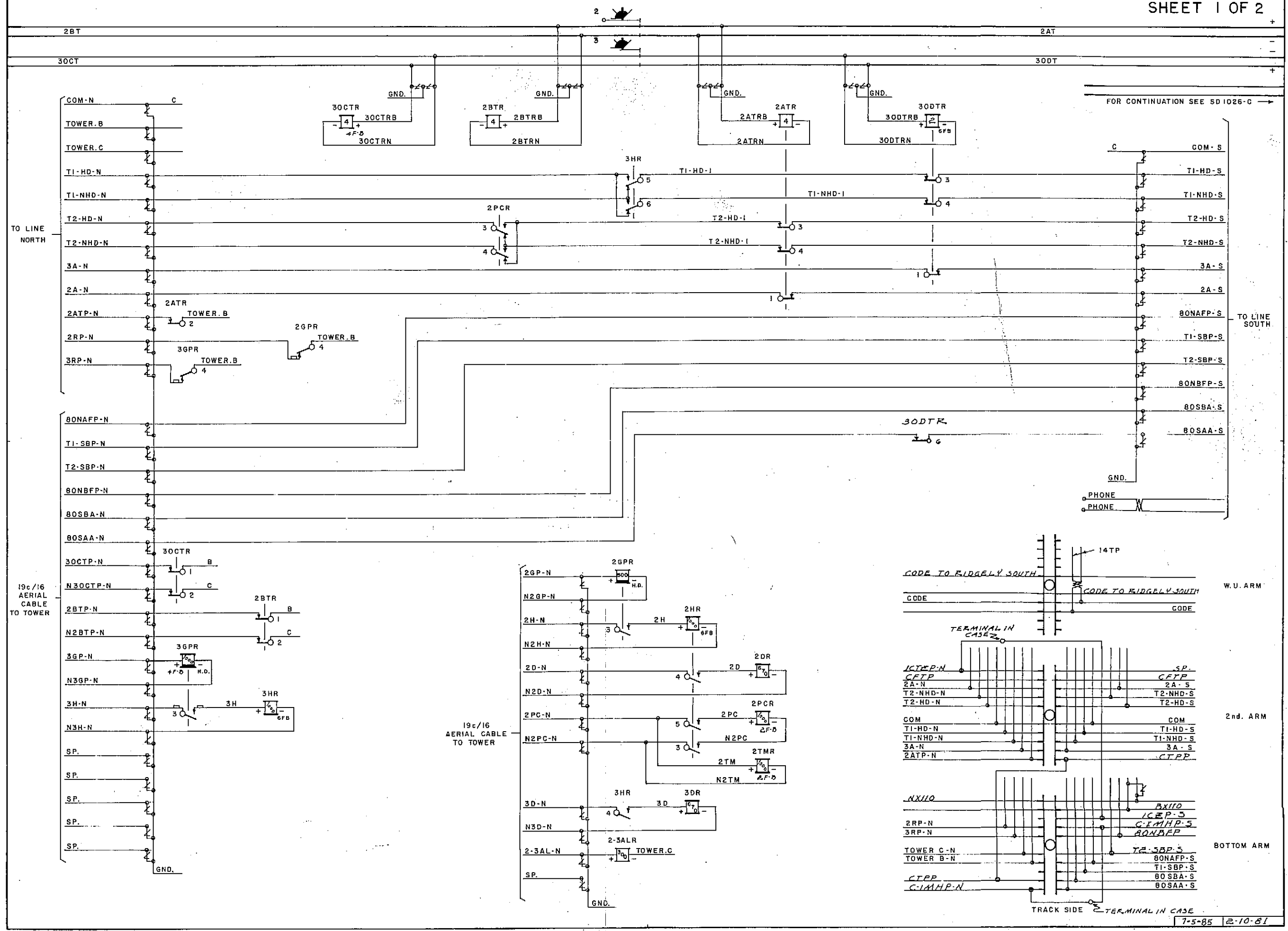

19c/16 AERIAL CABLE TO TOWER

19c/16 AERIAL CABLE TO TOWER

CODE TO RIDGELY SOUTH

TERMINAL IN CASE

1st ARM

2nd ARM

AX110

2RP-N  
3RP-N  
TOWER C-N  
TOWER B-N  
CTPP  
C-1MHP-N

TRACK SIDE

IN AS LS

31

RIDGELY, ILL. SD 112-C  
MP 182.92 TO MP 182.93  
SHEET 2

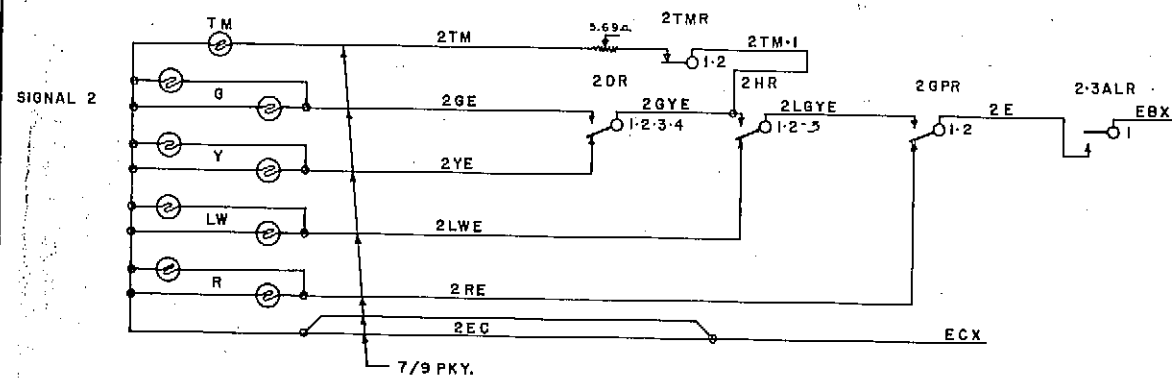

LUNAR  
STILL hooked UP

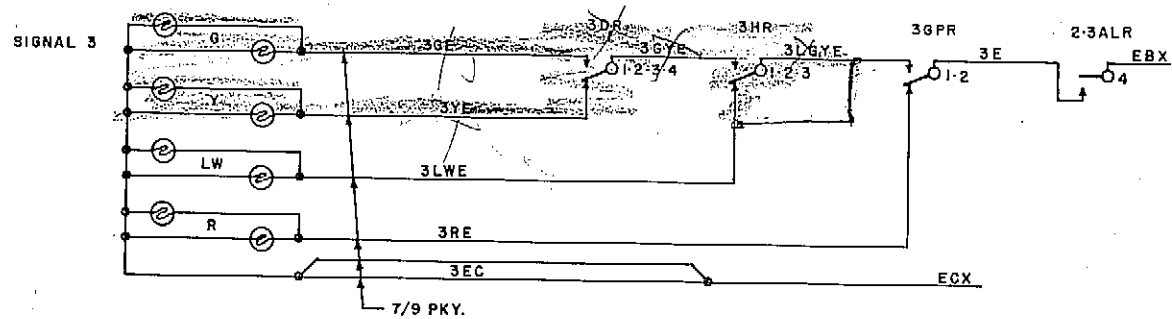

3 GP UP  
LUNAR

Yellow IN

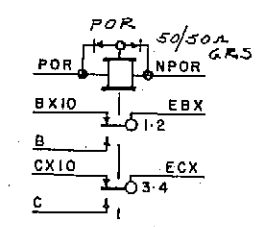
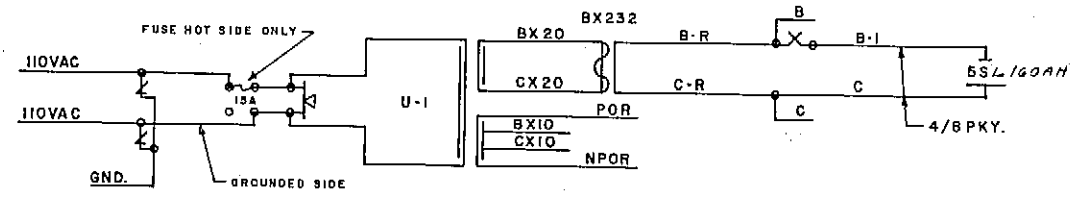
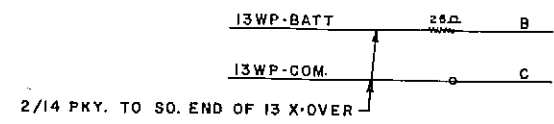

← FOR CONTINUATION SEE SD 1026-C

3842'

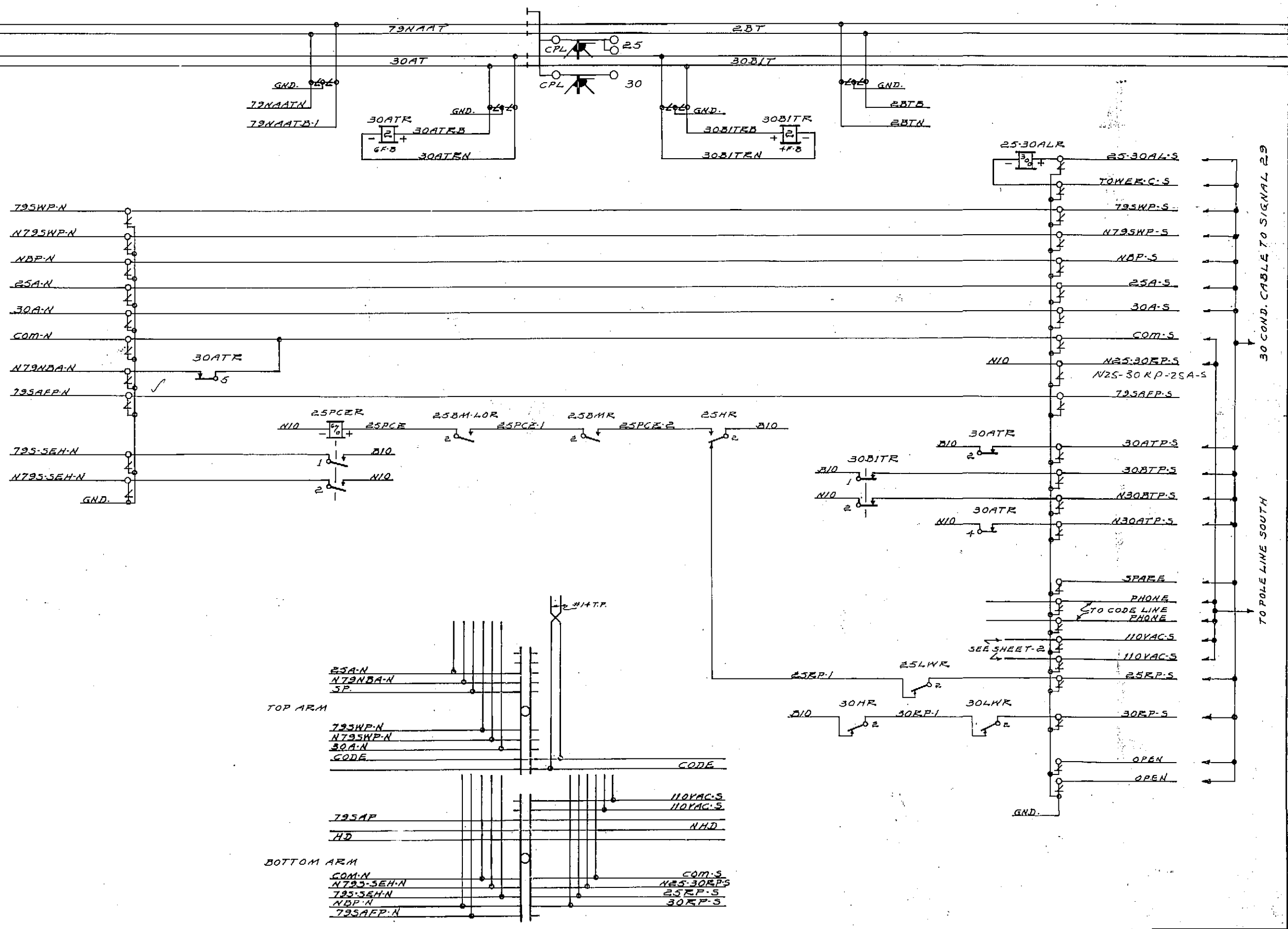

30 COND. CABLE TO SIGNAL 29

TO POLE LINE SOUTH

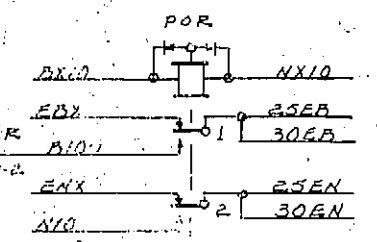
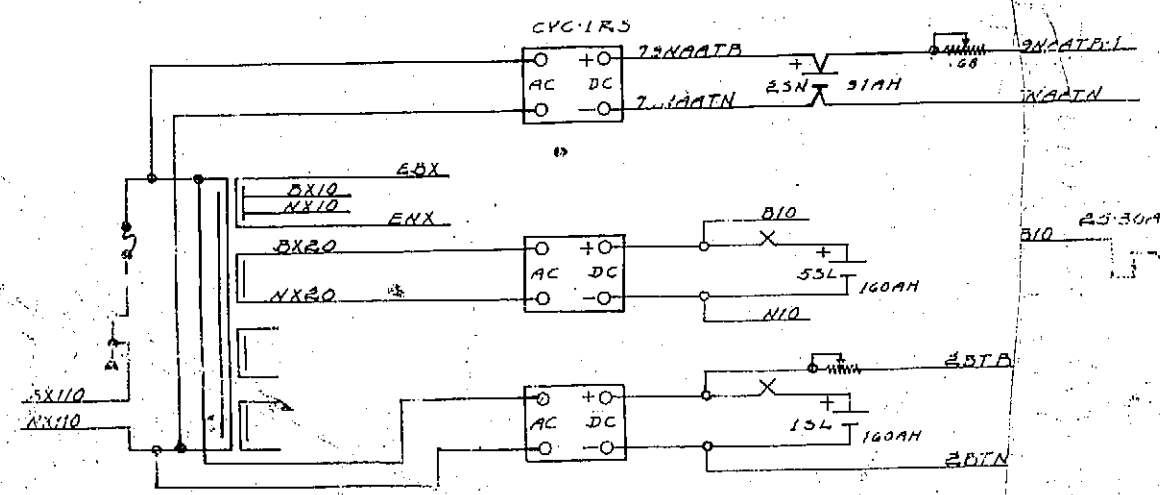
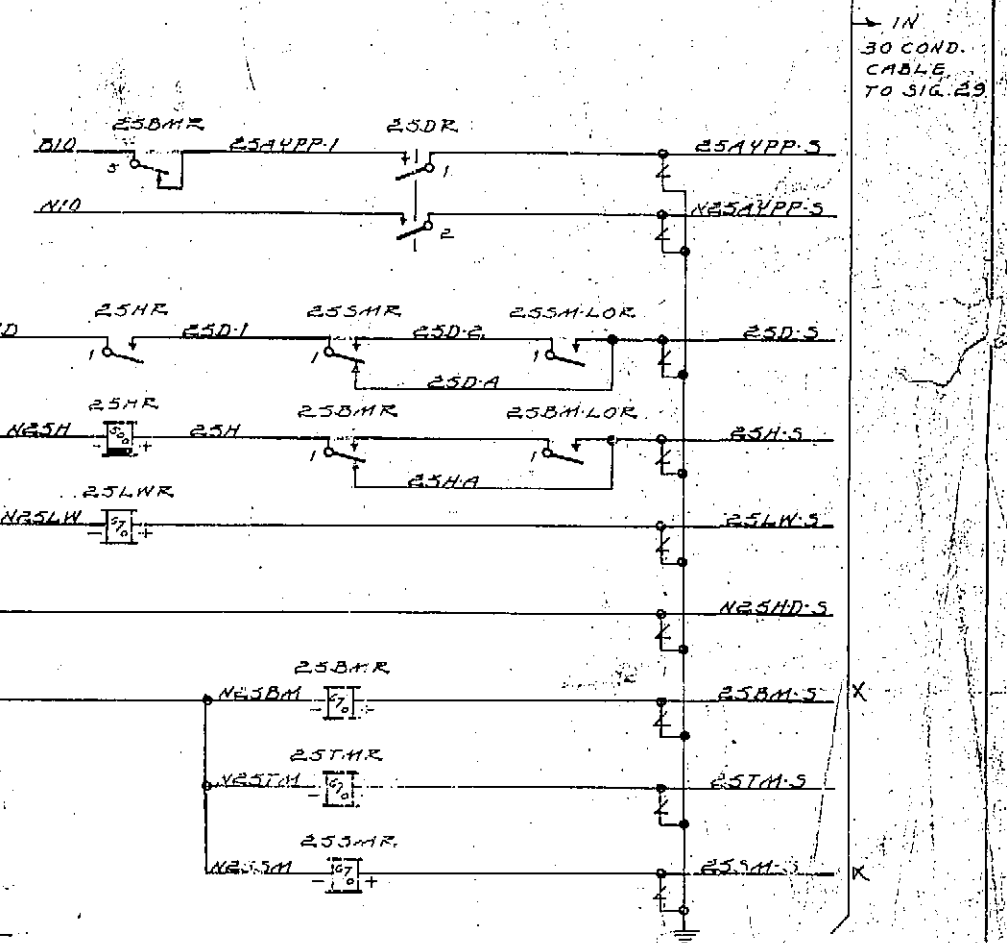
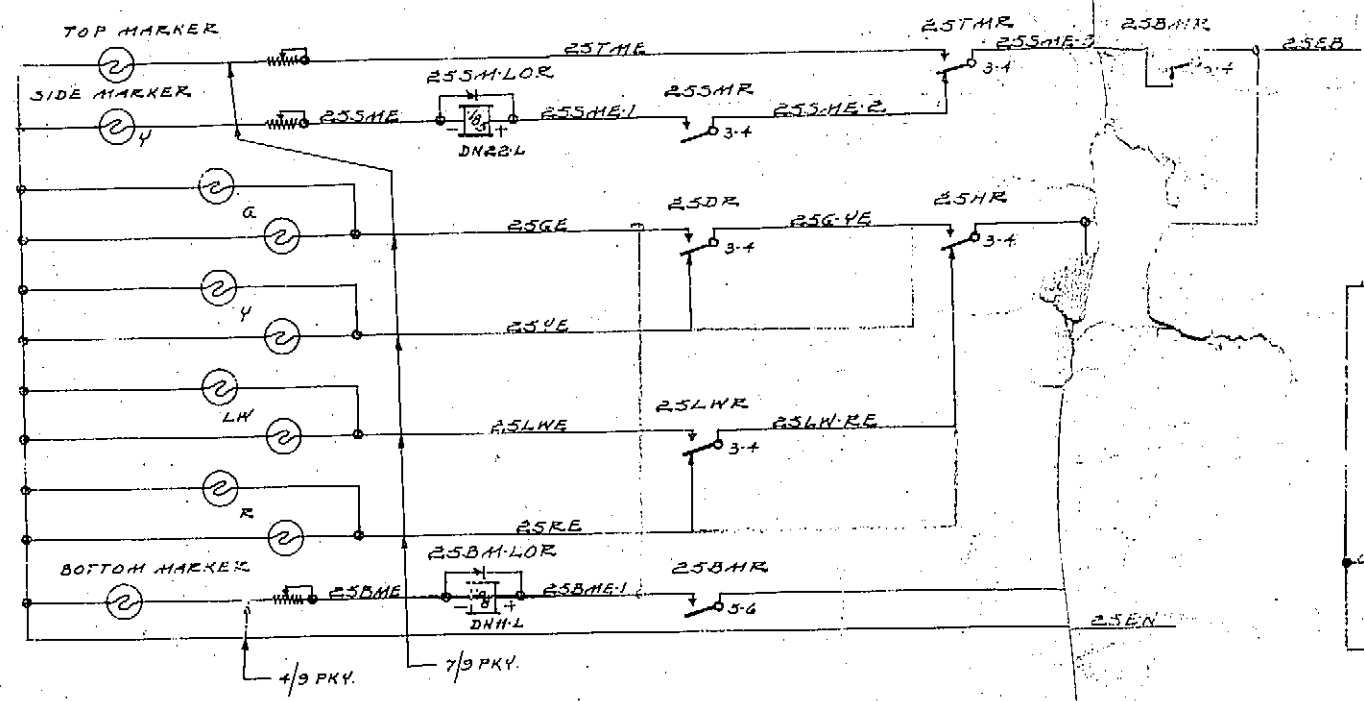
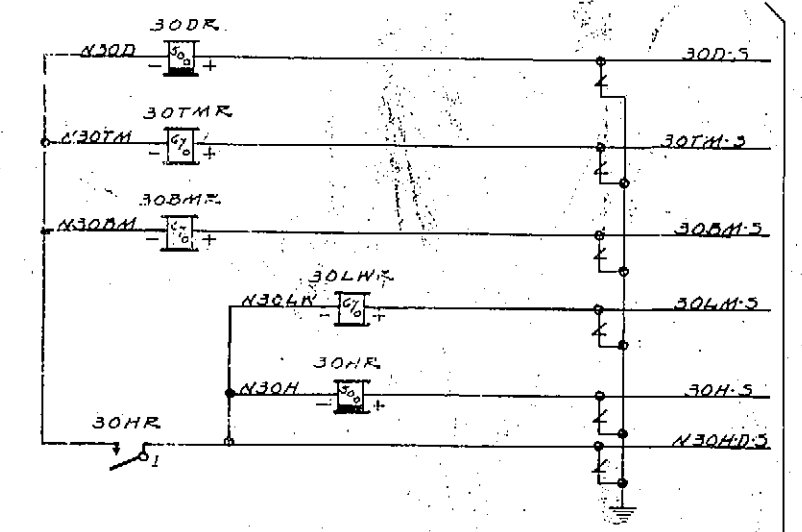
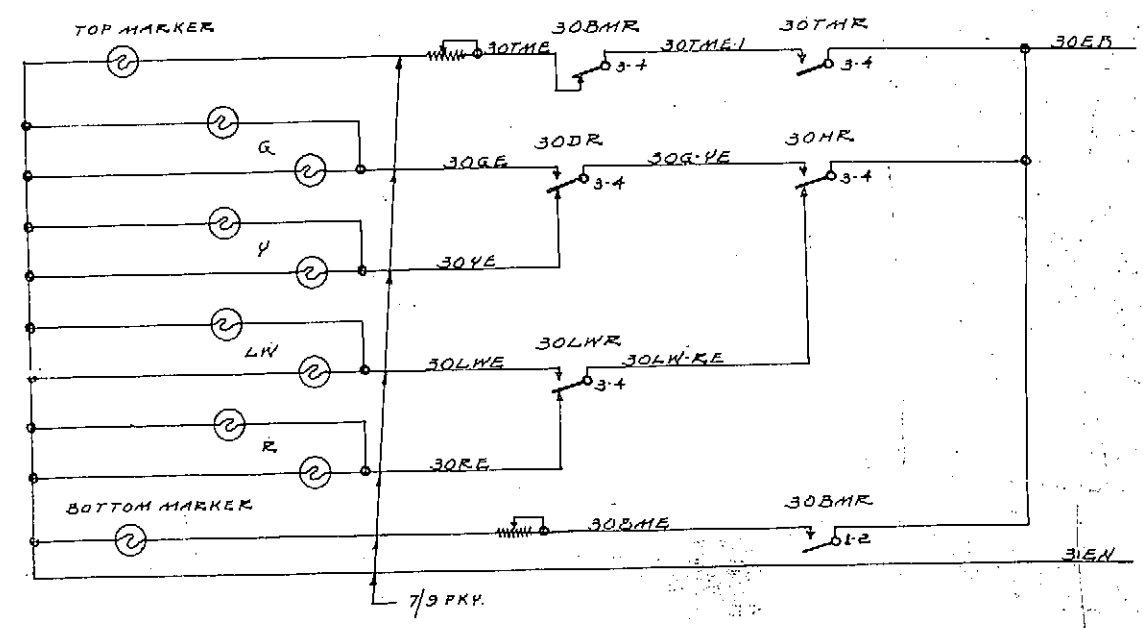

IN  
30 COND.  
CABLE  
TO SIG. 29



