

# CENTRALIZED TRAFFIC CONTROL

CATALOG  
Section "T"

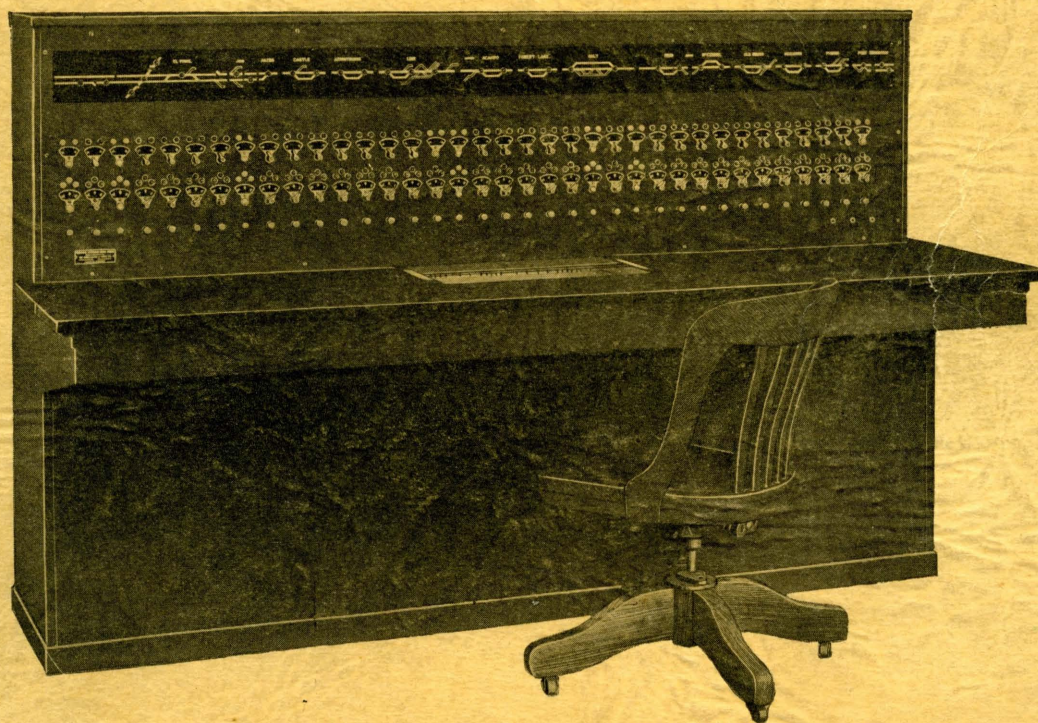

Union Switch & Signal Co.  
Swissvale, Pa.

No. 306

July, 1941



CENTRALIZED TRAFFIC CONTROL

SECTION

T

Before placing orders for C.T.C. equipment, it is important that the following information and instructions be read:-

This catalogue contains ordering references for detailed parts used in Union Centralized Traffic Control and Direct Wire (C.T.C.Type) systems.

The large number of slightly different complete assemblies which are made from a relatively few sub-assemblies makes it advisable, in general, to list sub-assemblies and inadvisable to attempt to list the complete assemblies.

Orders can be filled with the greatest assurance of satisfaction and the minimum amount of correspondence if they are written in accordance with the following instructions.

(a) Orders for complete assemblies for replacements should state the nomenclature of the assembly being replaced and the installation on which it is to be used (See ordering instructions at top of plate lists).

(b) Orders for complete assemblies not for replacement should describe the make up of the complete assembly in terms of sub-assemblies or their component parts. (See ordering instructions at top of plate lists).

This catalog is of a temporary nature and is intended to serve immediate needs or until such time as designs are sufficiently stabilized to justify printing for insertion in our official Loose Leaf Catalog Covers.



UNION SWITCH & SIGNAL CO.  
SWISSVALE, PA.

August 1932

Printed in  
U.S.A.



# UNION SWITCH & SIGNAL CO.

## SECTION

"T"

### CENTRALIZED TRAFFIC CONTROL EQUIPMENT

#### TABLE OF CONTENTS

	Plate
CONTROL MACHINE (REAR VIEW).....	T-15-20
LAMP RECEPTACLES, LAMPS AND NAME PLATES.....	T-20
SWITCH AND SIGNAL LEVERS AND PUSH BUTTON CIRCUIT CONTROLLERS.....	T-21
4 AND 6 WAY OFFICE STORAGE UNITS.....	T-27
OFFICE CODING AND LINE, AND FIELD AND LINE, AND STORAGE UNITS.....	T-32
OFFICE CONTROL, AND FIELD STATION CONTROL UNITS.....	T-35
STYLE "L" RELAYS FOR OFFICE, LINE AND CODING, FIELD CODING AND LINE UNITS.....	T-54
CONTACT SPRING ASSEMBLIES FOR STYLE "L" RELAYS.....	T-55
CONTACT SPRING ASSEMBLIES FOR CIRCUIT CONTROLLERS.....	T-56
TERMINAL BOARDS, PLUG CONNECTORS AND RECTIFIERS FOR OFFICE AND FIELD STATION CONTROL UNITS.....	T-60
SWITCHBOARDS, RESISTORS, SWITCHES, ETC.....	T-62
TERMINAL BOARDS, CONDENSERS, RESISTORS, ETC.....	T-65
TUNED ALTERNATOR.....	T-66
TRAIN GRAPH.....	T-67
TRAIN GRAPH.....	T-68
TRAIN GRAPH.....	T-68A
DRIVING MECHANISM.....	T-69
DRIVING MECHANISM.....	T-69A
DRIVING MECHANISM.....	T-69B
TRAIN GRAPH DETAILS.....	T-71
CYCLE RECORDER, TOOLS AND SUPPLIES FOR MAINTENANCE.....	T-75
OFFICE AND FIELD TEST SET.....	T-77
CONDENSER CASE.....	T-80
STYLE "P-3" POLAR RELAY.....	T-83
STYLE "P-4" BIASED POLAR RELAY.....	T-84
BELLS.....	T-85



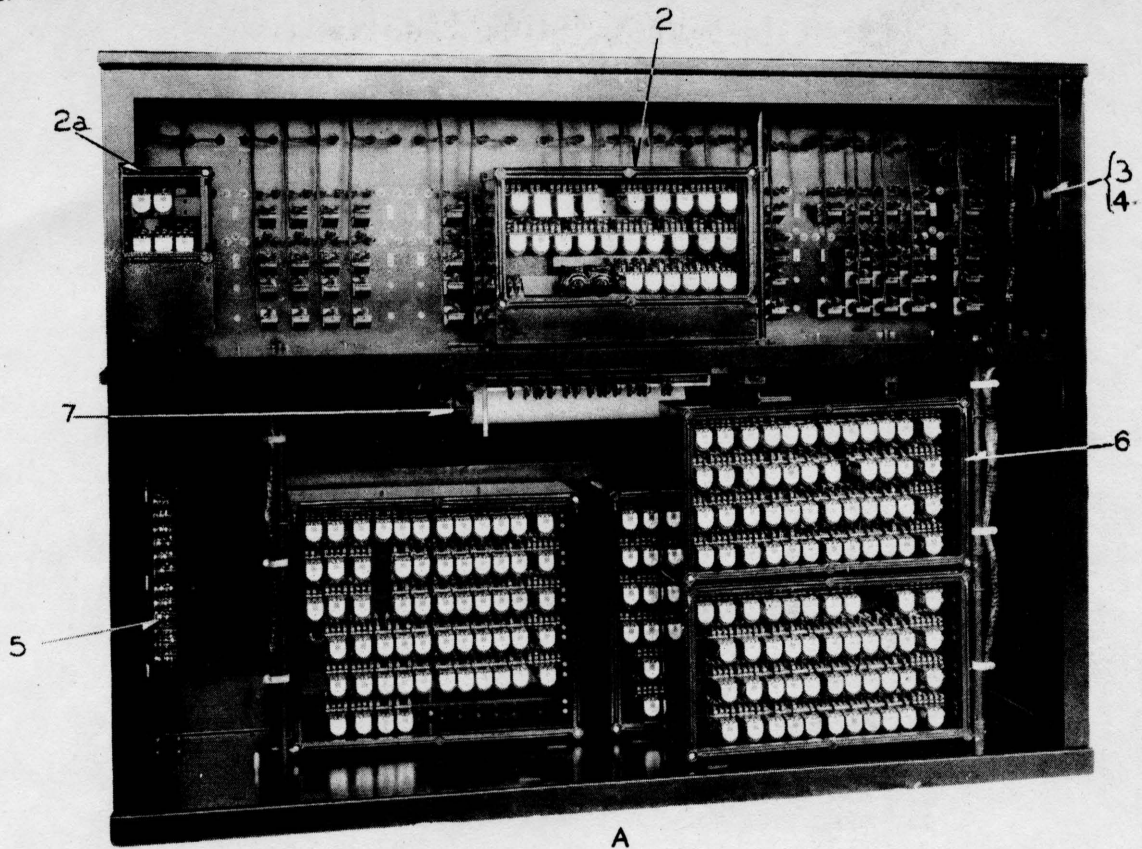

A  
CONTROL MACHINE - REAR VIEW

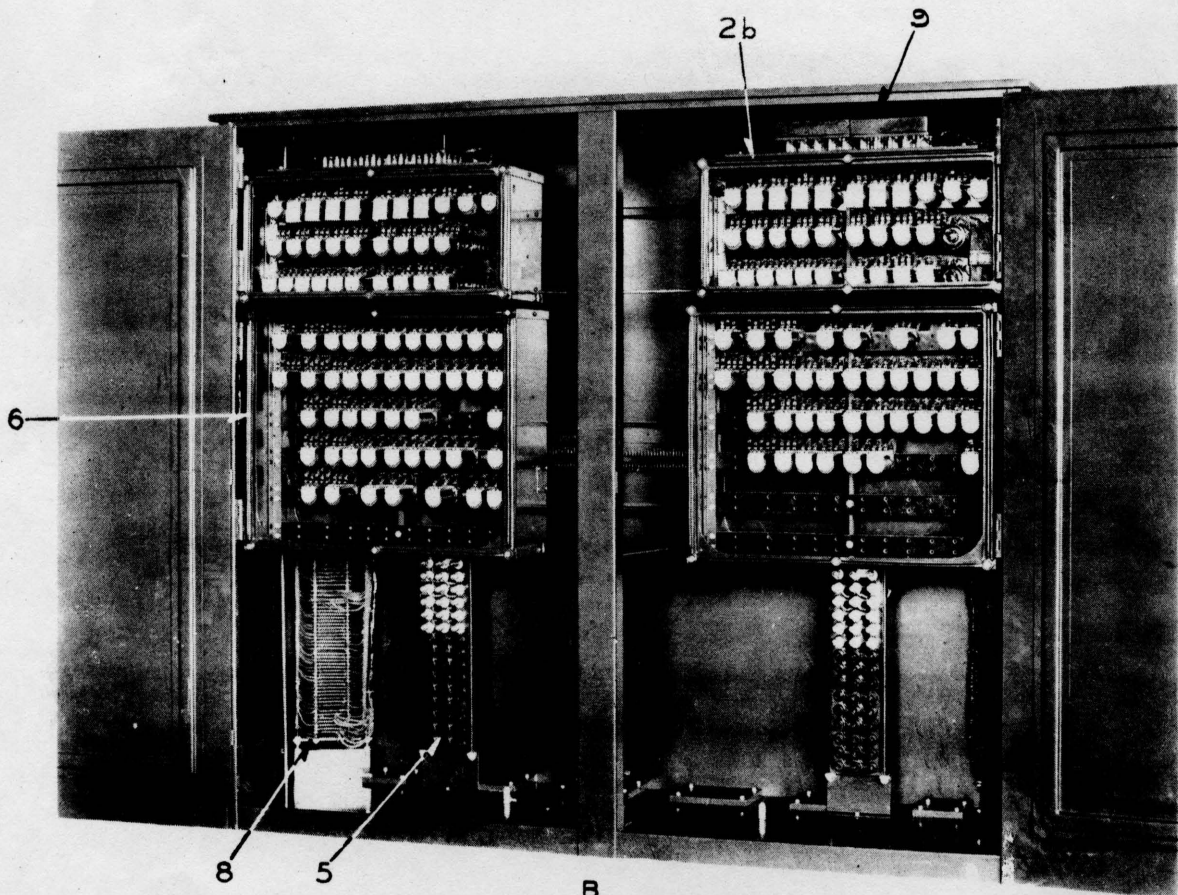

B  
CONTROL MACHINE - REAR VIEW



# UNION SWITCH & SIGNAL CO.

## CENTRALIZED TRAFFIC CONTROL SYSTEM

### CONTROL MACHINE

#### REAR VIEW

ORDER BY PLATE, PIECE, REFERENCE AND ABBREVIATED DESCRIPTION GIVEN IN HEAVY FACE TYPE STATING INSTALLATION FOR WHICH REQUIRED.

Piece	Ref.	Description	Drawing Reference
	A	CONTROL MACHINE (Single Cabinet Type)	
	B	CONTROL MACHINE (Multiple Unit Cabinet Type)	
	2	OFFICE CODING UNIT (When ordering refer to Plate T-32)	
	2a	OFFICE LINE UNIT (When ordering refer to Plate T-32)	
	2b	OFFICE LINE CODING UNIT (When ordering refer to Plate T-35)	
	3	SINGLE STROKE BELL, TYPE D.S.-4 Standard Tone (25 ohms resistance for 12 Volt D.C. Operation) (With four Screws Ref.4, for details see Plate T-85)	
	3a	SINGLE STROKE BELL, TYPE D.S.-4-2, Soft Tone (25 ohms resistance for 12 Volt D.C. Operation) (With four Screws Ref.4, for details see Plate T-85)	
	3b	SINGLE STROKE BELL, TYPE D.S.-4 Standard Tone (25 ohms resistance for 16 Volt D.C. Operation) (With four Screws Ref.4, for details see Plate T-85)	
	3c	VIBRATING BELL, TYPE D.V.-4, 4" Gong (24 Volt D.C.) (with four Screws Ref.4, for details see Plate T-85)	
	3d	P-3 POLAR RELAY (Not shown), used with Vibrating Bell (3c). for details see Plate T-85	
	4	MACHINE SCREW, NO.8-36 x 1/4" Rd.Hd.S.(N.P.) for attaching Bell to Case.	
	5	MULTIPLE UNIT TERMINAL BOARD (When ordering refer to Plate P-7310)	
	6	OFFICE STORAGE UNIT (When ordering refer to Plate T-27)	
	7	TRAIN GRAPH (For details refer to Plates T-67, T-69 & T-71)	
	8	CONNECTING FRAME	
	9	PLUG CONNECTOR for office line coding unit (When ordering refer to Plate T-60)	



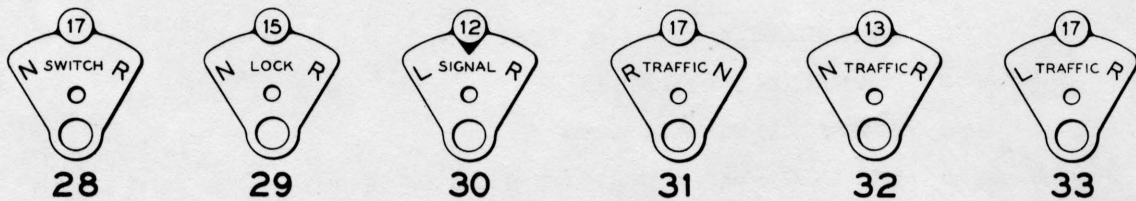
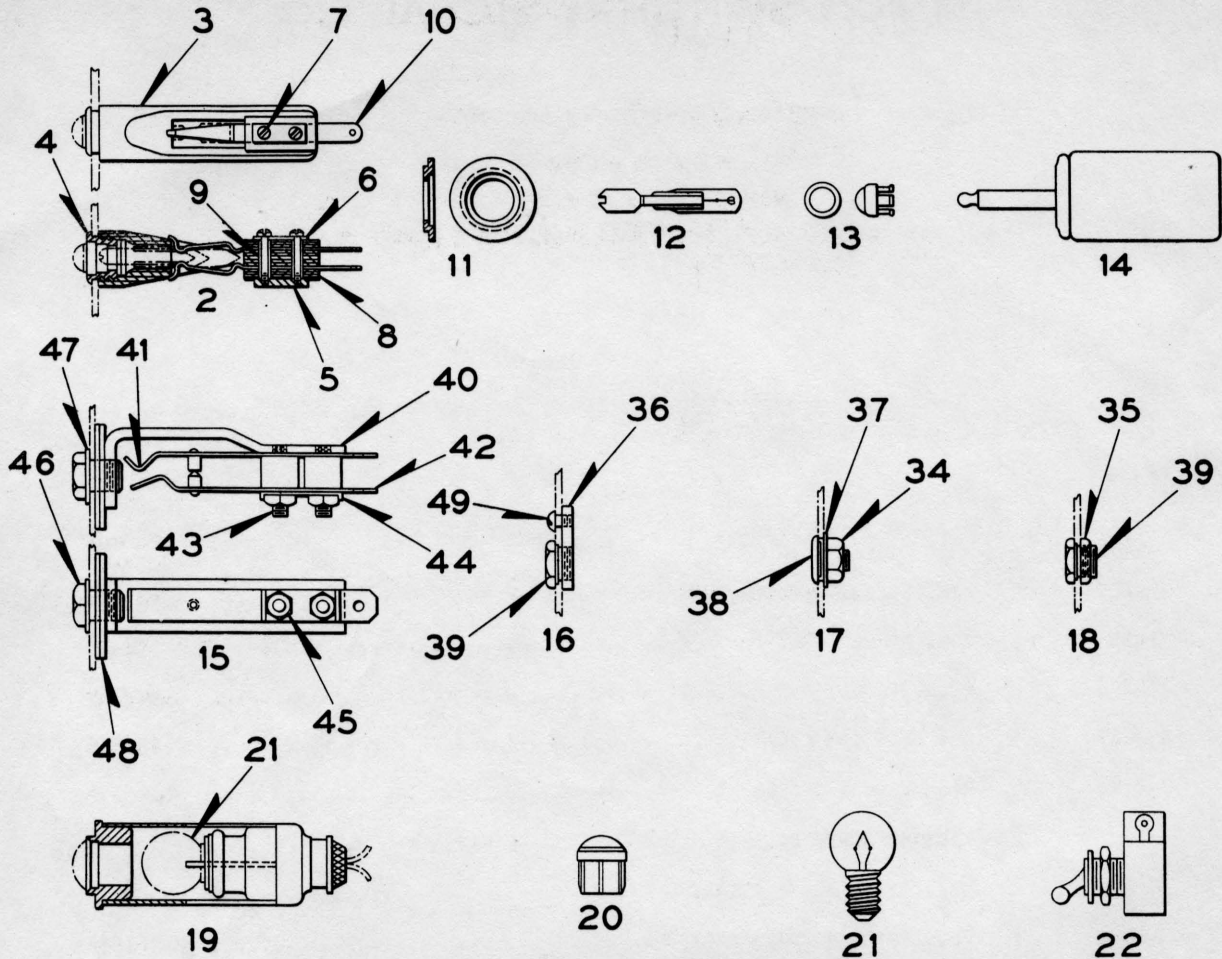

LAMP RECEPTACLES, NAME PLATES, ETC.  
(CABINET FRONT PLATE DETAILS)



# UNION SWITCH & SIGNAL CO.

## CENTRALIZED TRAFFIC CONTROL SYSTEM

### DETAIL PARTS OF CONTROL MACHINE

#### MOUNTED ON FRONT PLATE

LAMP RECEPTACLES, LAMPS, TOGGLE SWITCHES, NUMBER PLATES,  
JACKS, AND PLUGS.

ORDER BY PLATE, PIECE, REFERENCE AND ABBREVIATED DESCRIPTION  
GIVEN IN HEAVY FACE TYPE STATING INSTALLATION FOR WHICH REQUIRED.

Piece	Ref.	Description	Drawing Reference
154829	2	LAMP RECEPTACLE COMPLETE (without Lamp or Lamp Cap).....	12522-14
154830	3	LAMP HOLDER ONLY for Ref.2.....	12522-15
154849	4	BUSHING ONLY for Ref.2.....	8350-763
156117	5	NUT ONLY for Ref.2.....	7828-285
152720	6	WASHER ONLY for Ref.2.....	7828-275
	7	MACHINE SCREW NO.3-56 x 5/8" Fil.Hd.S.(N.P.) for Ref.2	
174235	8	INSULATION BLOCK ONLY for Ref.2.....	8750-2503
154481	9	INSULATION BUSHING ONLY for Ref.2.....	B-10266-1
154847	10	CONTACT SPRING ONLY for Ref.2.....	8385-2185
156916	11	BUSHING for Ref.2 (Used on track model) - - - - -	8350-775
	12	SWITCHBOARD LAMP (Specify Voltage)	
150745	13	RED LAMP CAP.....	12522-11
150746	13a	GREEN LAMP CAP.....	12522-11
150747	13b	WHITE LAMP CAP.....	12522-11
155416	13c	AMBER LAMP CAP.....	12522-11
	14	PILOT PHONE PLUG #214, for Ammeter Jack	
159153	15	AMMETER JACK COMPLETE, with Bushing, Washer and Ins.Washers...	12619-6
	16	DUMMY FILLER for Switch or Signal Lever	
	17	DUMMY FILLER for Lamp	
	18	DUMMY FILLER for Push Button	
156907	19	SPOT LIGHT SOCKET without Lamp Ref.21 and Lamp Cap.....	12522-17
120682	20	GREEN LAMP CAP.....	12522-4
120681	20a	RED LAMP CAP.....	12522-4
128842	20b	AMBER LAMP CAP.....	12522-4



# UNION SWITCH & SIGNAL CO.

PIECE	REF.	DESCRIPTION	DWG. REF.
120226	21	CANDELABRA SCREW BASE LAMP, G-6 for Ref.19.....	B-12409-11
	22	TOGGLE SWITCH COMPLETE, with Nuts for attaching to Case	
155006	23	SIGNAL LEVER NAME PLATE (Orders should specify lever number required).....	8225-331
155007	24	SWITCH LEVER NAME PLATE (Orders should specify lever number required).....	8225-331
158412	25	SIGNAL LEVER NAME PLATE (Not Numbered).....	8225-338
158413	26	SWITCH LEVER NAME PLATE (Not Numbered).....	8225-338
161080	27	SIGNAL LEVER NAME PLATE (Orders should specify lever number required).....	8225-347
160051	28	SWITCH LEVER NAME PLATE (Orders should specify lever Number required).....	8225-341
160052	29	LOCK LEVER NAME PLATE (Orders should specify lever Number required).....	8225-341
160053	30	SIGNAL LEVER NAME PLATE (Orders should specify lever Number required).....	8225-341
171919	31	TRAFFIC LEVER NAME PLATE (Orders should specify lever Number required).....	8225-391
178040	32	TRAFFIC LEVER NAME PLATE (Orders should specify lever Number required).....	8225-391
170030	33	TRAFFIC LEVER NAME PLATE (Orders should specify lever Number required).....	8225-385
26977	34	HEX.NUT ONLY for Ref.17.....	8109-186
29714	35	HEX.NUT ONLY for Ref.18.....	8109-207
159181	36	PLATE ONLY for Ref.16.....	12538-54
939	37	WASHER ONLY for Ref.17.....	7828-7
159180	38	STUD ONLY for Ref. 17 (N.P.).....	10933-48
163630	38a	STUD ONLY for Ref. 17 (Head painted Olive Green).....	10933-48
192643	38b	STUD ONLY for Ref. 17 (Head painted Rubber Finish).....	10933-48
159182	39	STUD ONLY for Refs. 16 and 18 (N.P.).....	8190-375
163631	39a	STUD ONLY for Refs. 16 and 18 (Head painted Olive Green).....	8190-375
140796	40	BRACKET for Ref. 15.....	11893-327
140779	41	CONTACT SPRING for Ref. 15.....	8385-2059
140778	42	CONTACT SPRING for Ref. 15.....	8385-2058
22621	43	BUSHING for Ref. 15.....	8095-199
74798	44	LOCK WASHER for Ref. 15.....	8486-155
1515	45	HEX. NUT for Ref. 15.....	8109-23
159152	46	BUSHING for Ref. 15.....	8095-672



## UNION SWITCH &amp; SIGNAL CO.

PIECE	REF.	DESCRIPTION	DWG. REF.
67612	47	WASHER for Ref. 15.....	7828-287
42858	48	INS. WASHER for Ref. 15.....	8078-191
	49	MACHINE SCREW, NO. 6-40 x 1/4" Rd. Hd. Br. (N.P.)	
	49a	MACHINE SCREW, NO. 6-40 x 1/4" Rd. Hd. Br. (Head painted Olive Green)	

7-35



# PLATE T-21

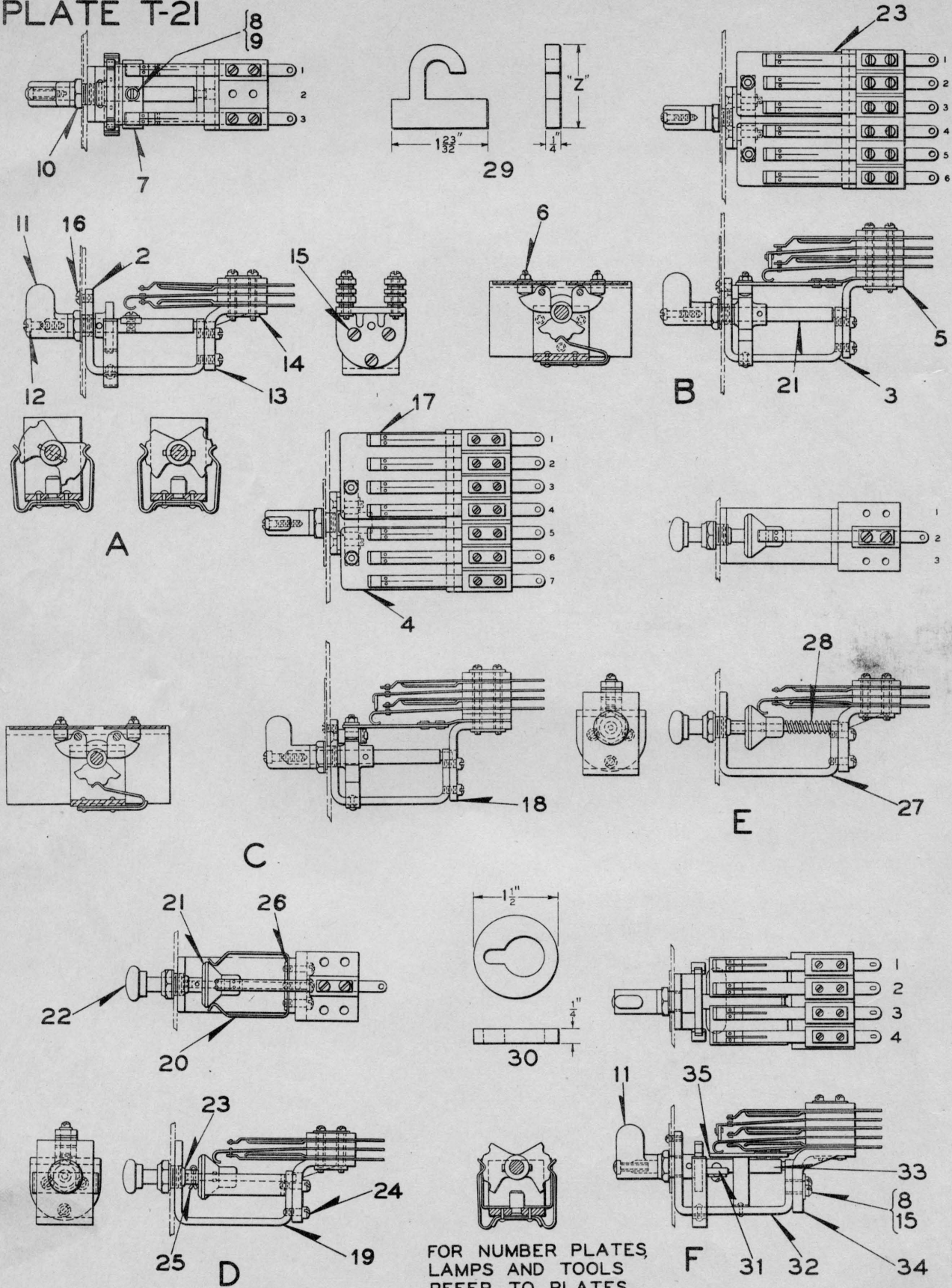

FOR NUMBER PLATES,  
LAMPS AND TOOLS  
REFER TO PLATES  
T-20 AND T-75

2-15-39

## SWITCH AND SIG. CIR. CONTRS. AND PUSH BUTTONS

# UNION SWITCH & SIGNAL Co.

CENTRALIZED TRAFFIC CONTROL SYSTEM

DETAIL PARTS

SWITCH LEVER, SIGNAL LEVER, AND PUSH BUTTON  
CIRCUIT CONTROLLERS

If ordering complete levers for replacement state installation, nomenclature and exact location on cabinet front plate.

If ordering complete levers, not for replacement, state nomenclature and contact combination required for each stack assembly.

These levers and push buttons are designed for mounting on 1/16" ± 1/64" panel. If mounting for thicker panel is desired, orders should specify panel thickness.

**Order by Plate, Piece, Reference and Abbreviated Description Given in Heavy Face Type Only**

PIECE	REF.	DESCRIPTION	DWG. REF.
	A	LEVER CIRCUIT CONTROLLER, 2 or 3 POSITION (Maximum contact capacity - 2 contact assemblies per Plate T-56)	
	B	LEVER CIRCUIT CONTROLLER, 2 or 3 POSITION (Maximum contact capacity - 6 contact assemblies per Plate T-56)	
	C	LEVER CIRCUIT CONTROLLER, 2 or 3 POSITION (Maximum contact capacity - 7 contact assemblies per Plate T-56)	
	D	PUSH BUTTON CIRCUIT CONTROLLER, 2 POSITION (Maximum contact capacity - one contact assembly per Plate T-56)	
	E	PUSH BUTTON CIRCUIT CONTROLLER (SPRING RETURN) (Maximum contact capacity - one contact assembly per Plate T-56)	
	F	LEVER CIRCUIT CONTROLLER, 2 or 3 POSITION (Maximum contact capacity - 4 contact assemblies per Plate T-56)	
171774	2	BRACKET COMPLETE with Spring, Stud, Support and Rivets, for A.	10914-323
171721	3	BRACKET COMPLETE with Spring, Support and Stud for Refs.B & C.	10914-322
181321	4	CONTACT ARM COMPLETE (R.H.) with Springs, Stud and Eyelets....	8750-2412
166478	4a	CONTACT ARM COMPLETE (L.H.) with Springs, Stud and Eyelets....	8750-2412
171451	5	SUPPORT.....	8750-2477
166905	6	STUD with Nut and Washer.....	8114-752
410508	6a	WASHER for Stud Ref.6	
29351	6b	NUT for Stud Ref.6.....	8109-204
160226	7	OPERATING ARM.....	8750-2328
20686	8	WASHER.....	7828-108
	9	MACHINE SCREW, NO.6-40 x 5/16" Rd.Hd.Br. (N.P.)	
154474	10	BUSHING.....	8350-760
154473	11	HANDLE for Refs.A, B, C and F.....	8311-86
	12	MACHINE SCREW, NO.6-40 x 1/2" Fil.Hd.Br. (N.P.)	
170982	13	SUPPORT.....	8750-2476
156117	14	WASHER for Refs.A, B, C and F.....	7828-285
	15	MACHINE SCREW, NO.6-40 x 3/8" Fil.Hd.S. (N.P.)	
	16	MACHINE SCREW, NO.6-40 x 1/4" Rd.Hd.Br. (N.P.) for attaching Number Plate to Bracket	
166480	17	CONTACT ARM COMPLETE.....	8750-2411



# UNION SWITCH & SIGNAL CO.

PIECE	REF.	DESCRIPTION	DWG. REF.
171452	18	SUPPORT.....	8750-2478
169267	19	BRACKET.....	10914-313
171484	20	SPRING.....	8735-742
171421	21	OPERATING ROD COMPLETE.....	8095-690
154937	22	KNOB.....	8235-143
154934	23	SPRING.....	8124-229
	24	MACHINE SCREW, NO.6-40 x 7/16" Fil.Hd.S. (N.P.)	
	25	COTTER PIN, 1/16" x 1/2" Steel (Cad.Pl.)	
171261	26	WASHER.....	7828-285
169266	27	BRACKET.....	10914-313
171121	28	SPRING.....	8124-218
103286	29	LEVER TAG (RED) "Z" dimension 1-1/2".....	8988-160
103287	29a	LEVER TAG (WHITE) "Z" dimension 1-1/2".....	8988-160
103284	29b	PUSH BUTTON BLOCKING TAG (RED) "Z" dimension 1-5/16".....	8988-160
103285	29c	PUSH BUTTON BLOCKING TAG (WHITE) "Z" dimension 1-5/16".....	8988-160
177285	30	PUSH BUTTON BLOCKING TAG (RED).....	8078-1532
100510	31	OPERATING ARM COMPLETE.....	12538-164
100513	32	BRACKET COMPLETE.....	10914-786
106150	32a	BRACKET COMPLETE (With Stop Stud for operating Cam from C to R position only).....	10914-786
106149	32b	BRACKET COMPLETE (With Stop Stud for operating Cam from C to L position only).....	10914-786
171775	33	SHAFT.....	12501-71
100508	34	BRACKET.....	8750-2781
100507	35	OPERATING LEVER COMPLETE.....	8750-2780

# UNION SWITCH & SIGNAL CO.

PLATE T-27

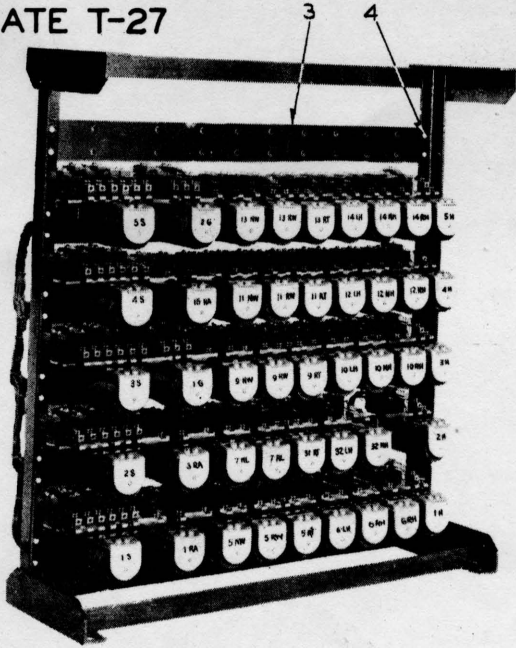

OFFICE STORAGE RACK  
12 STATION BASIS  
TIME CODE

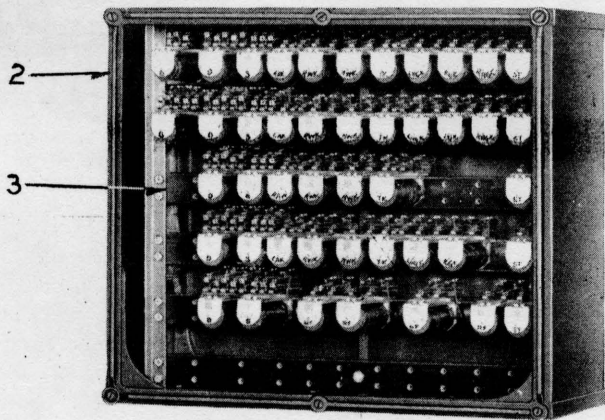

STORAGE UNIT  
35 STATION BASIS  
TIME CODE

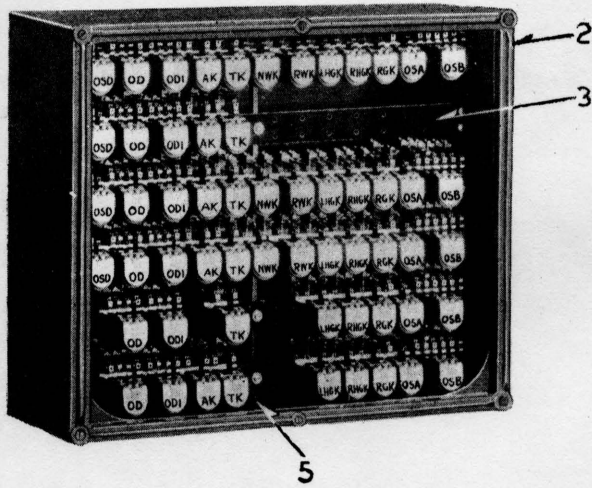

OFFICE STORAGE UNIT  
81 STATION BASIS  
CIRCUIT CODE

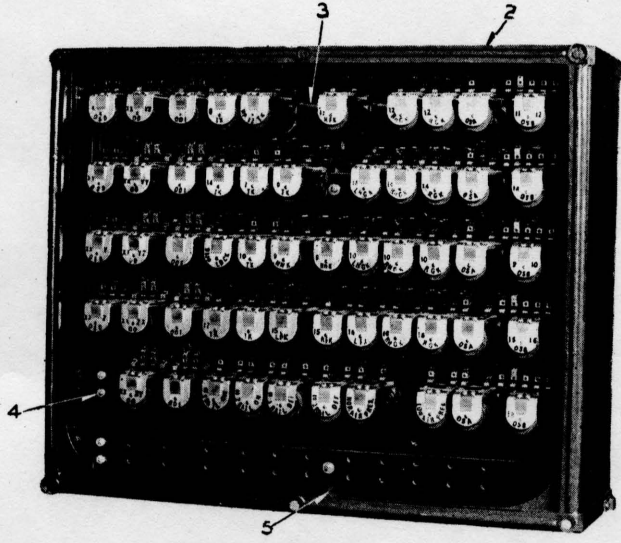

INTERCHANGEABLE OFFICE STORAGE UNIT  
81 STATION BASIS  
CIRCUIT CODE

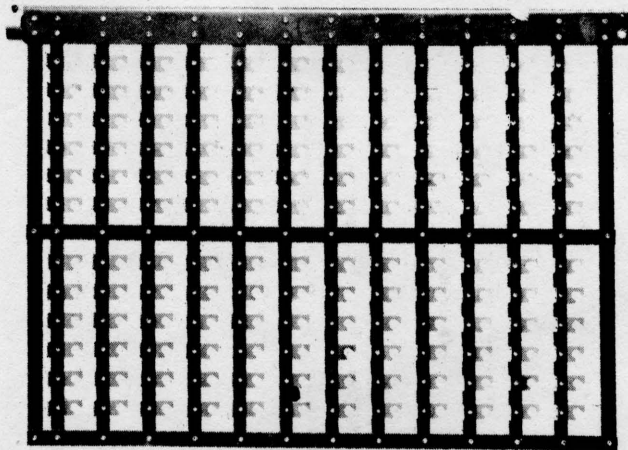



# UNION SWITCH & SIGNAL CO.

## CENTRALIZED TRAFFIC CONTROL SYSTEM

### OFFICE STORAGE UNITS

For details and complete Relays refer to Plate T-54.

ORDER BY PLATE, AND DESCRIPTION GIVEN IN HEAVY FACE TYPE STATING  
INSTALLATION FOR WHICH REQUIRED.

Piece	Ref.	Description	Drawing Reference
		WHEN ORDERING COMPLETE RELAYS FOR REPLACEMENT, GIVE RELAY NOMENCLATURE AS WELL AS INSTALLATION FOR WHICH REQUIRED.	
	2	DOOR FRAME	
	2a	GLASS SHIELD	
	2b	FELT GASKET	
	2c	MACHINE SCREW, NO.10-30 x 5/8" Flat Hd.S.(N.P.) for attaching door Ref.2 to Case (Corners)	
	2d	MACHINE SCREW, NO.10-30 x 1" Flat Hd.S.(N.P.) for attaching door Ref.2 to Case (Center)	
	3	SUPPORT for Relays	
	4	MACHINE SCREW, NO.10-30 x 7/16" Fil.Hd.S.(N.P.) with Washer Ref.4a for attaching Relays to Support.	
44618	4a	WASHER ONLY, for Refs.4 and 4d.....	7828-184
	4b	NO.10 SHAKEPROOF LOCK WASHER, for Ref.4d	
	4c	10-30 HEX.NUT S. (N.P.)	
	4d	MACHINE SCREW, NO.10-30 x 5/8" Fil.Hd.S.(N.P.) with Washer Ref.4a, Lock Washer Ref.4b and Hex.Nut Ref.4c for attaching Support Ref.3 to Angle Iron.	
	5	SUPPORTING STRIP	
	5a	MACHINE SCREW, NO.8-36 x 1/2" Flat Hd.S.(N.P.) for attaching Supporting Strip to Case	
	5b	MACHINE SCREW, NO.8-36 x 1/2" Fil.Hd.S.(N.P.) with Washer Ref.5c for attaching Bakelite Supports to Supporting Strip	
53	5c	WASHER ONLY, for Ref.5b.....	7828-5
	6	TERMINAL RACK FOR INTERCHANGABLE OFFICE STORAGE UNIT	
		NOTE:-Specify whether parts are for 4-way or 6-way Case when ordering.	

PLATE T-32

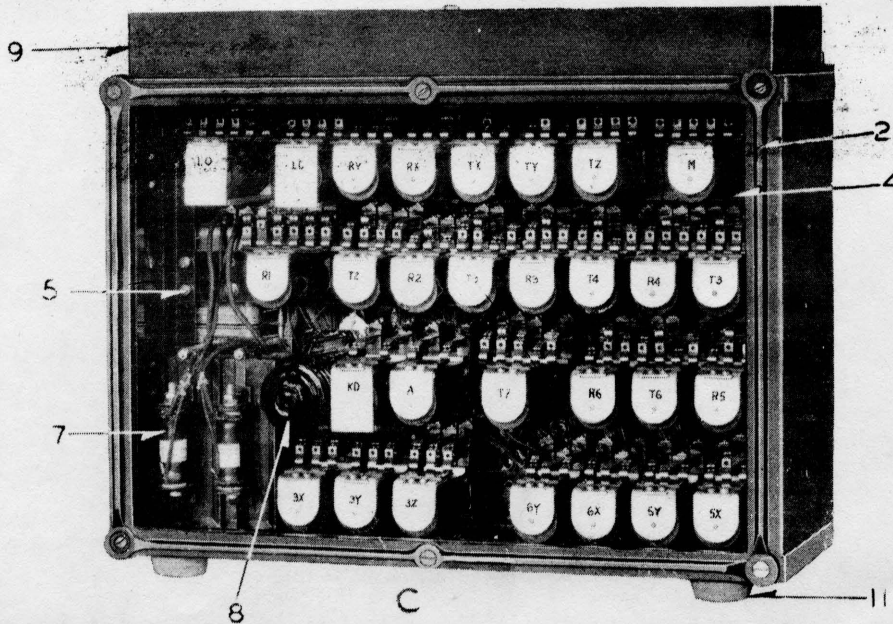
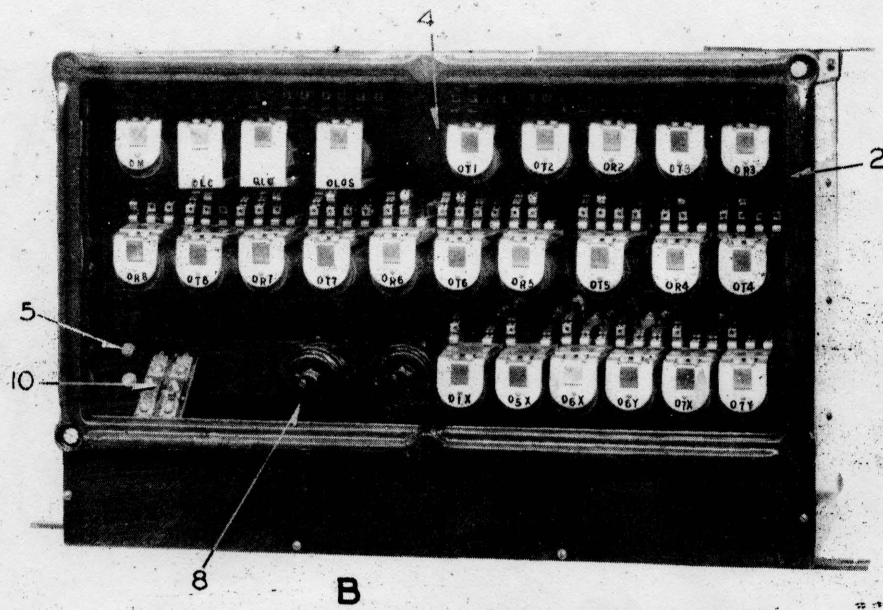
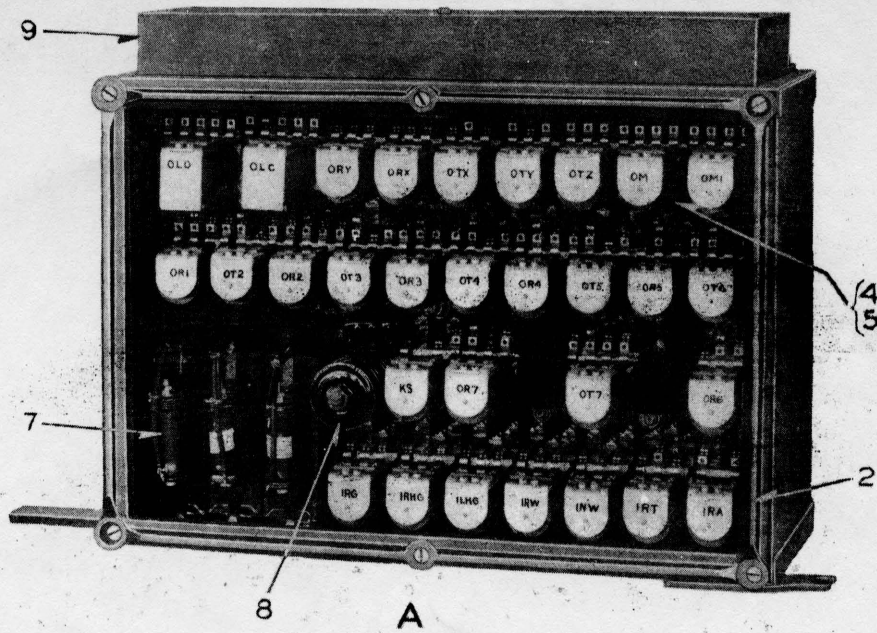



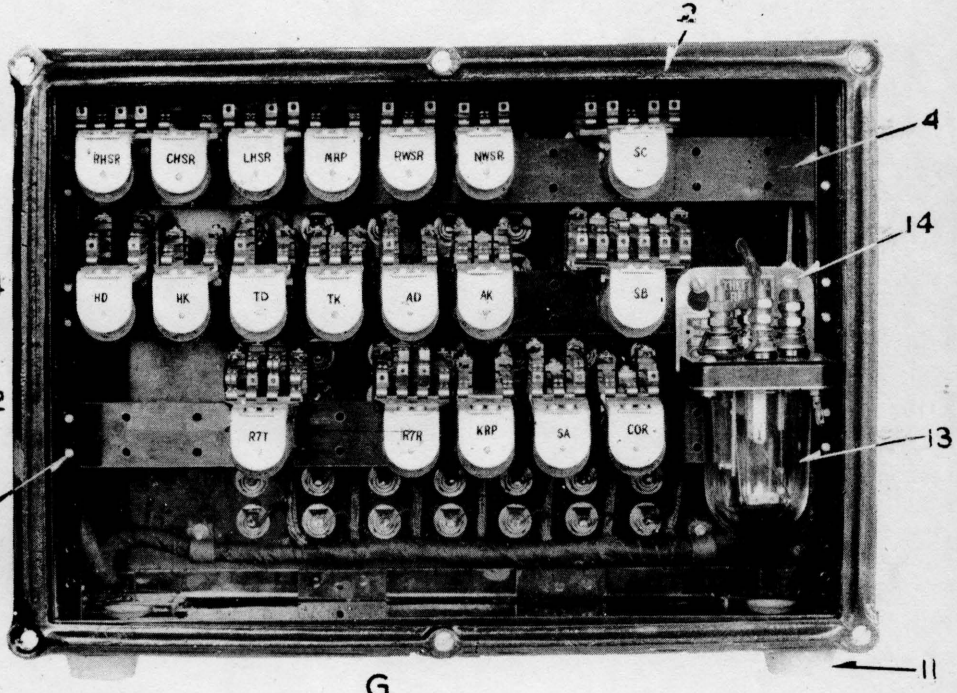
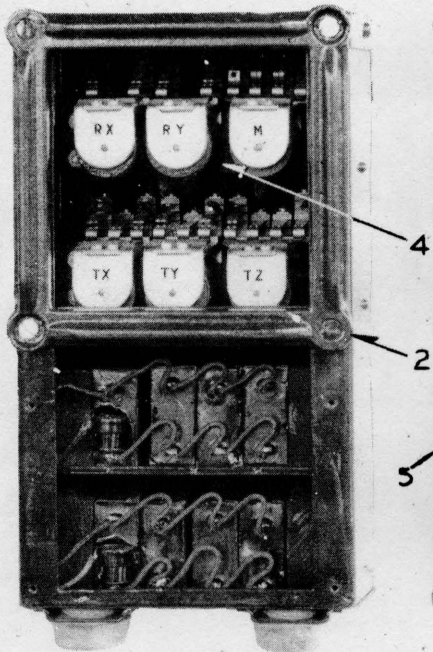
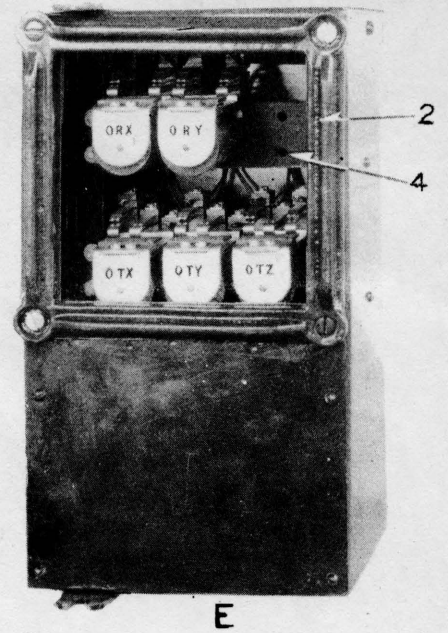
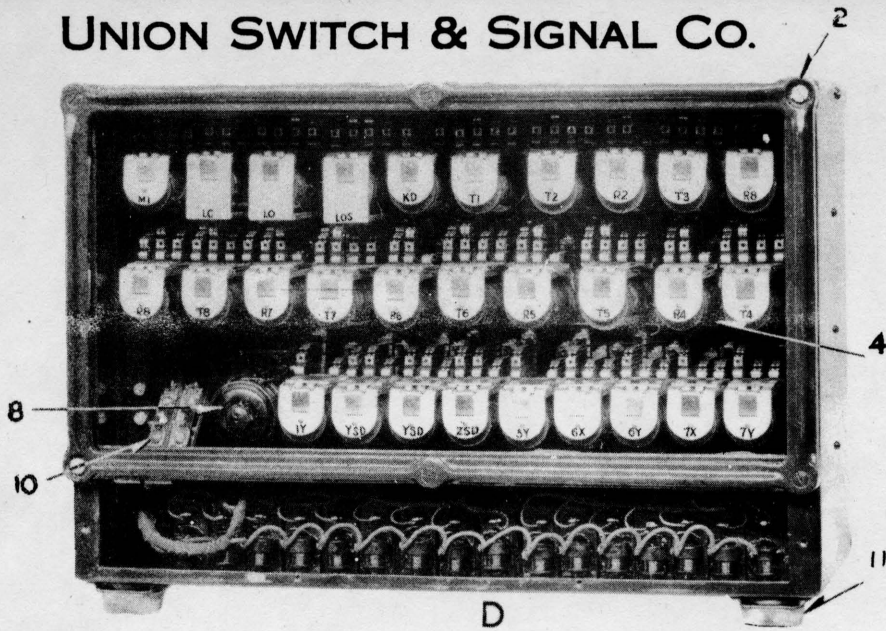

F

G

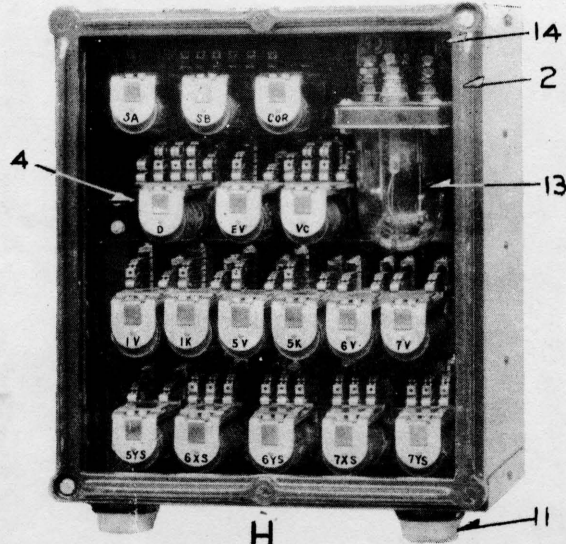

H

CENTRALIZED TRAFFIC CONTROL  
 DETAILS  
 CODING, LINE AND STORAGE UNITS

# UNION SWITCH & SIGNAL CO.

## CENTRALIZED TRAFFIC CONTROL SYSTEM

For details and complete relays refer to Plate T-54.

### CIRCUIT CODE SYSTEM

ORDER BY PLATE AND DESCRIPTION GIVEN IN HEAVY FACE TYPE, STATING INSTALLATION FOR WHICH REQUIRED.

Piece	Ref.	Description	REMARKS
	A	OFFICE CODING UNIT .....	27 Station Basis
	B	OFFICE CODING UNIT .....	81 Station Basis
	C	FIELD CODING UNIT .....	27 Station Basis
	D	FIELD <sup>CODING</sup> UNIT .....	81 Station Basis
	E	OFFICE LINE UNIT .....	81 Station Basis
	F	FIELD LINE UNIT .....	81 Station Basis
	G	FIELD STORAGE UNIT .....	27 Station Basis
	H	FIELD STORAGE UNIT .....	81 Station Basis
	REF.	DESCRIPTION	REMARKS
		WHEN ORDERING COMPLETE RELAYS FOR REPLACEMENT GIVE RELAY NOMENCLATURE AS WELL AS THE INSTALLATION.	
	2	DOOR FRAME	
	2a	GLASS SHIELD, for Door Frame	
	2b	FELT GASKET ONLY, for Ref.2	
	2c	MACHINE SCREW NO.10-30 x 5/8" Flat Hd.S.(N.P.) for attaching Door Ref.2 to Case (Corners)	
	2d	MACHINE SCREW NO.10-30 x 1" Flat Hd.S.(N.P.) for attaching Door Ref.2 to Case (Center)	
	3	TERMINAL BOARD (NOT SHOWN) COMPLETE, with Terminal Posts, Nuts, Washers, Lock Washers, Connectors and Marking Strips (For details refer to Plate T-65)	
	4	SUPPORT FOR RELAYS (When ordering state rows, numbering from top down)	



# UNION SWITCH & SIGNAL CO.

PIECE	REF.	DESCRIPTION	DWG. REF.
	5	MACHINE SCREW NO.10-30 x 7/16" Fil.Hd.S.(N.P.) with Washer, Ref.4a of Plate T-27, for attaching Relays to Support.	
	5a	MACHINE SCREW NO.10-30 x 5/8" Fil.Hd.S.(N.P.) with Washer Ref. 4a, Lock Washer Ref.4b and Hex.Nut Ref.4c of Plate T-27 for attaching Support Ref.4 to Angle Iron.	
	6	MACHINE SCREW NO.10-30 x 5/8" Fil.Hd.S.(N.P.) with Washer Ref. 4a of Plate T-27 for attaching Rectifier to Support Ref.4	
	7	CONDENSER AND RESISTOR COMPLETE, (For details refer to Plate T-65)	
	8	RECTIFIER UNIT COMPLETE (For details refer to Plate T-65)	
	9	CONDENSER CASE (For details refer to Plate T-80)	
	10	FUSE AND BLOCK COMPLETE (For details refer to Plate T-65)	
	11	RUBBER BUTTON	
	12	RESISTANCE UNIT COMPLETE (Not shown)	
	13	THERMAL RELAY (For details refer to Plate E-5220)	
	13a	THERMAL RELAY (Not Shown) (Later design not covered by Plate E-5220)	
	14	MACHINE SCREW NO.10-30 x 3/4" Fil.Hd.S.(N.P.) with No.10 Plain S.Lock Washer (1/8" x 3/64") (Cad.Pl.) with Washer Ref. 4a of Plate T-27 and Nut Ref.14b of this Plate for attaching Thermal Relay to Support.	
	14a	MACHINE SCREW NO.14-24 x 7/8" Fil.Hd.S.(N.P.) with 1/4" Plain S.Lock Washer (1/8" x 1/16") (Cad.Pl.) with two Nuts Ref.14c and Washer Ref.14d for attaching Thermal Relay to Support.	
52727	14b	NUT for Ref.14.....	8265-126
31670	14c	NUT for Ref.14a.....	8109-218
29104	14d	WASHER for Ref.14a.....	7828-138

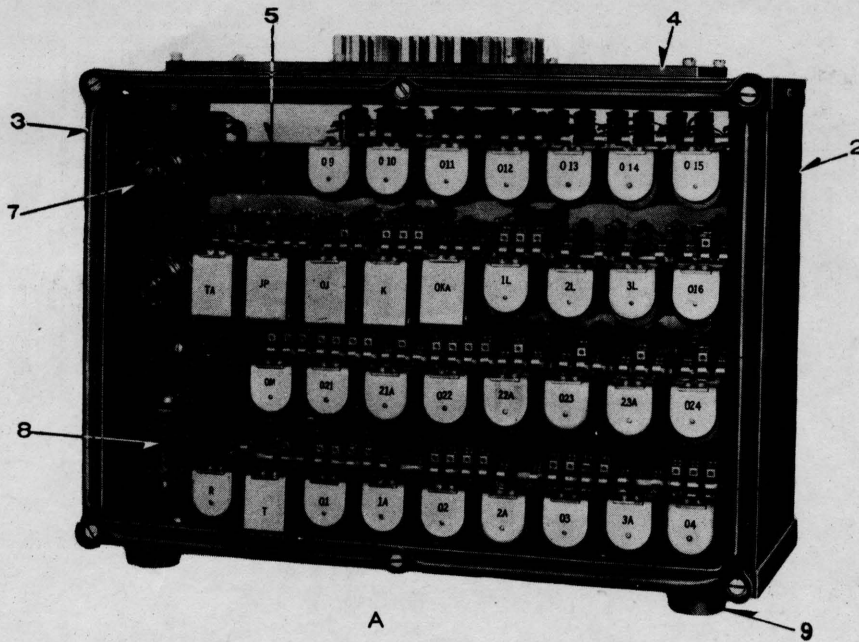

A  
OFFICE CONTROL UNIT  
12 STATION BASIS

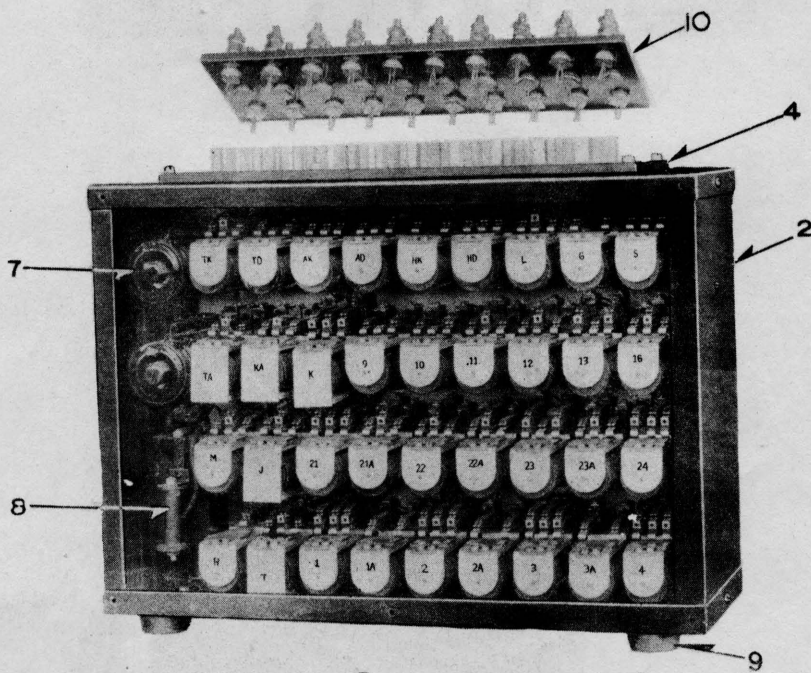

B  
FIELD STATION CONTROL UNIT  
12 STATION BASIS



# UNION SWITCH & SIGNAL CO.

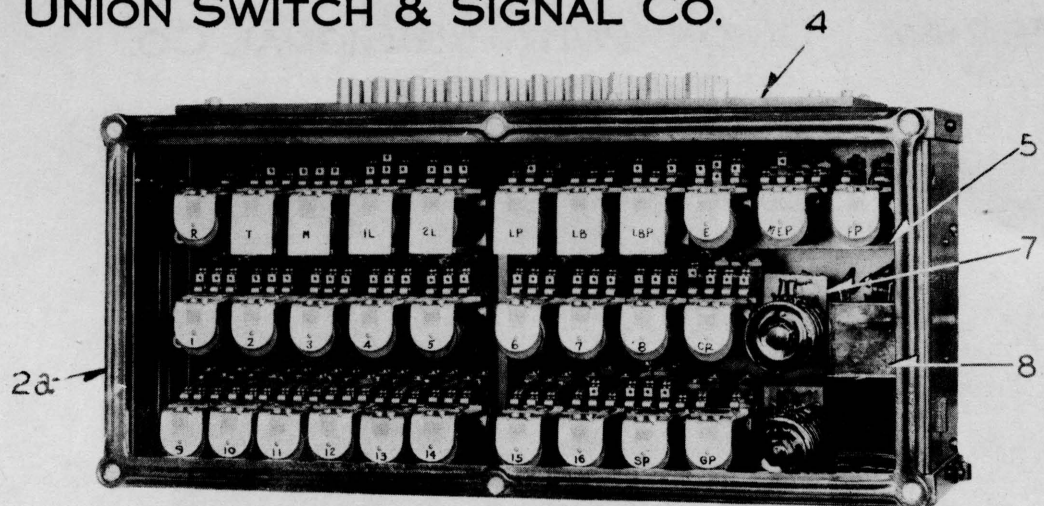

C  
OFFICE LINE CODING UNIT  
35 STATION BASIS

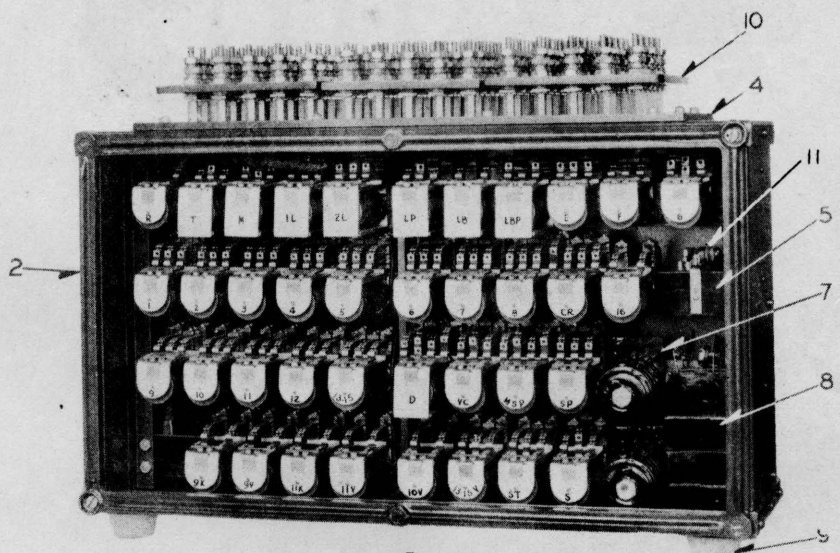

D  
FIELD LINE CODING STORAGE UNIT  
35 STATION BASIS

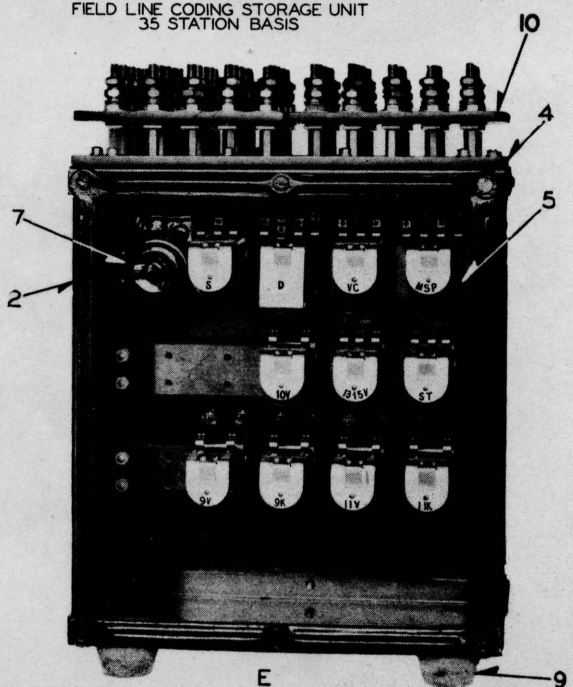

E  
FIELD STORAGE UNIT  
35 STATION BASIS

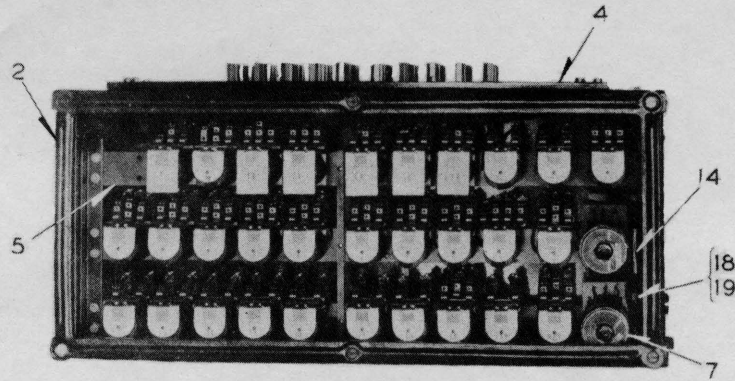

F

OFFICE LINE CODING UNIT  
35 STATION BIASED POLAR LINE CIRCUIT

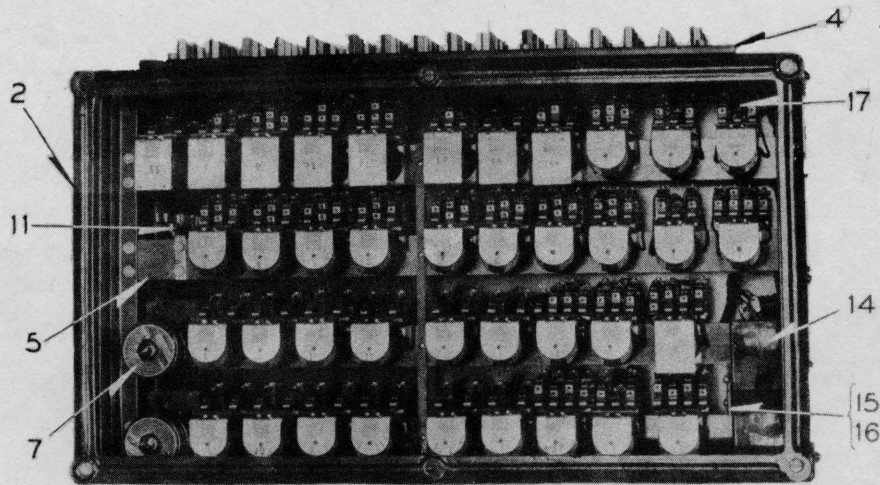

G

FIELD LINE CODING STORAGE UNIT  
35 STATION BIASED POLAR LINE CIRCUIT

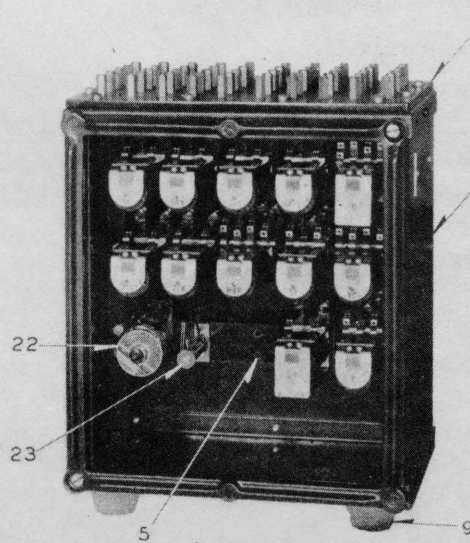

H

FIELD STORAGE UNIT  
35 STATION BIASED POLAR LINE CIRCUIT



# UNION SWITCH & SIGNAL CO.

## CENTRALIZED TRAFFIC CONTROL SYSTEM

For details and complete Relays refer to Plate T-54.

### TIME CODE SYSTEM

Order by Plate, Piece, Reference and Abbreviated Description Given in Heavy Face Type Only

PIECE	REF.	DESCRIPTION	REMARKS
	A	OFFICE CONTROL UNIT.....	12 Station Basis
	B	FIELD STATION CONTROL UNIT.....	12 Station Basis
	C	OFFICE LINE CODING UNIT.....	35 Station Basis
	D	FIELD LINE CODING STORAGE UNIT.....	35 Station Basis
	E	FIELD STORAGE UNIT.....	35 Station Basis
	F	OFFICE LINE CODING UNIT.....	35 Station Biased Pol. Line Cir.
	G	FIELD LINE CODING STORAGE UNIT.....	35 Station Biased Pol. Line Cir.
	H	FIELD STORAGE UNIT.....	35 Station Biased Pol. Line Cir.
PIECE	REF.	DESCRIPTION	DWG.REF.
		WHEN ORDERING COMPLETE RELAYS FOR REPLACEMENT GIVE RELAY NOMENCLATURE AS WELL AS THE INSTALLATION.	
	2	CASE COMPLETE, with Terminal Board, Cover, Glass Door and Rubber Buttons	
	2a	CASE COMPLETE, with Terminal Board, Cover, and Glass Door (Without Rubber Buttons)	
	3	DOOR FRAME	
	3a	GLASS SHIELD, for Door	
	3c	MACHINE SCREW NO.10-30 x 5/8" Flat Hd.S. (N.P.) for attaching Door Ref.3 to Case (Corners)	
	3d	MACHINE SCREW NO.10-30 x 1" Flat Hd.S. (N.P.) for attaching Door Ref.3 to Case (Center)	
	4	TERMINAL BOARD COMPLETE with Sockets, Nuts, Washers and Lock Washers (For details see Plate T-60)	
	5	BAKELITE SUPPORT for Relays	
	6	MACHINE SCREW NO.10-30 x 7/16" Fil.Hd.S. (N.P.) with Washer Ref.6b for attaching Relays to Support Ref.5 (Not shown)	
	6a	MACHINE SCREW NO.10-30 x 5/8" Fil.Hd.S. (N.P.) with Washer Ref.6b for attaching Rectifiers to Support Ref.5	

# UNION SWITCH & SIGNAL CO.

PIECE	REF.	DESCRIPTION	DWG. REF.		
44618	6b	WASHER ONLY, for Refs.6 and 6a.....	7828-184		
	6c	MACHINE SCREW, NO.10-30 x 5/8" Fil.Hd.S. (N.P.) with Washer Ref.6b of this Plate and Lock Washer Ref.4b and Hex.Nut Ref.4c of Plate T-27 for attaching Support Ref.5 to Angle Iron			
	7	TYPE RS-18 RECTIFIER (For details see Plate T-60)			
	8	SPARK ARRESTER UNIT, COMPLETE (For details see Plate T-60)			
	9	RUBBER BUTTON			
	10	PLUG CONNECTOR COMPLETE, for Field Control Unit (For details see Plate T-60)			
	10a	PLUG CONNECTOR COMPLETE, for Office Control Unit (For details see Plate T-60)			
	175203	11 THERMAL RELAY (Contact normally closed).....		B-12660-18	
	186614	11a		THERMAL RELAY (Contact normally open).....	B-12660-18
		12		RESISTOR COMPLETE (Not shown) (For details see Plate T-60).	
179928	13	MACHINE SCREW, NO.10-30 x 3/8" Rd.Hd.S. (N.P.) for attaching Resistor Ref.12 to Case (Not shown)	10914-475		
	14	CONDENSER AND RESISTOR COMPLETE (For details see Ref.S, Plate T-60)			
	15	MACHINE SCREW, NO.10-30 x 1/2" Fil.Hd.S. (N.P.) with No.10 Lock Washer (Internal Teeth) and No.10 Hex.Nut (N.P.) for attaching Ref.16 to Case			
	16	BRACKET (used when two Condensers and Resistors are used).....			
	17	RESISTOR, 500-ohms (Soldered directly to coil connector terminals of G relay in Field L-C-S unit and GP relay in Office L-C unit)			
101985	18	BRACKET (Used when One Condenser and Resistor is used).....	10914-857		
	19	MACHINE SCREW, NO.8-36 x 3/4" Flat Hd.S. (Tin Pl.) with Nut Ref.19a, for attaching Ref.18 to Case			
32498	19a	NUT for Ref.19.....	8109-223		
180502	20	WING NUT (Not shown).....	8331-78		
	21	TAP BOLT, 1/2" x 3/4" Hex.Hd.S. (Not shown)			
	22	TYPE RS-7 RECTIFIER (For details see Plate T-60)			
	23	RESISTANCE UNIT COMPLETE (For details see Ref.43, Plate T-60)			



# PLATE T-54

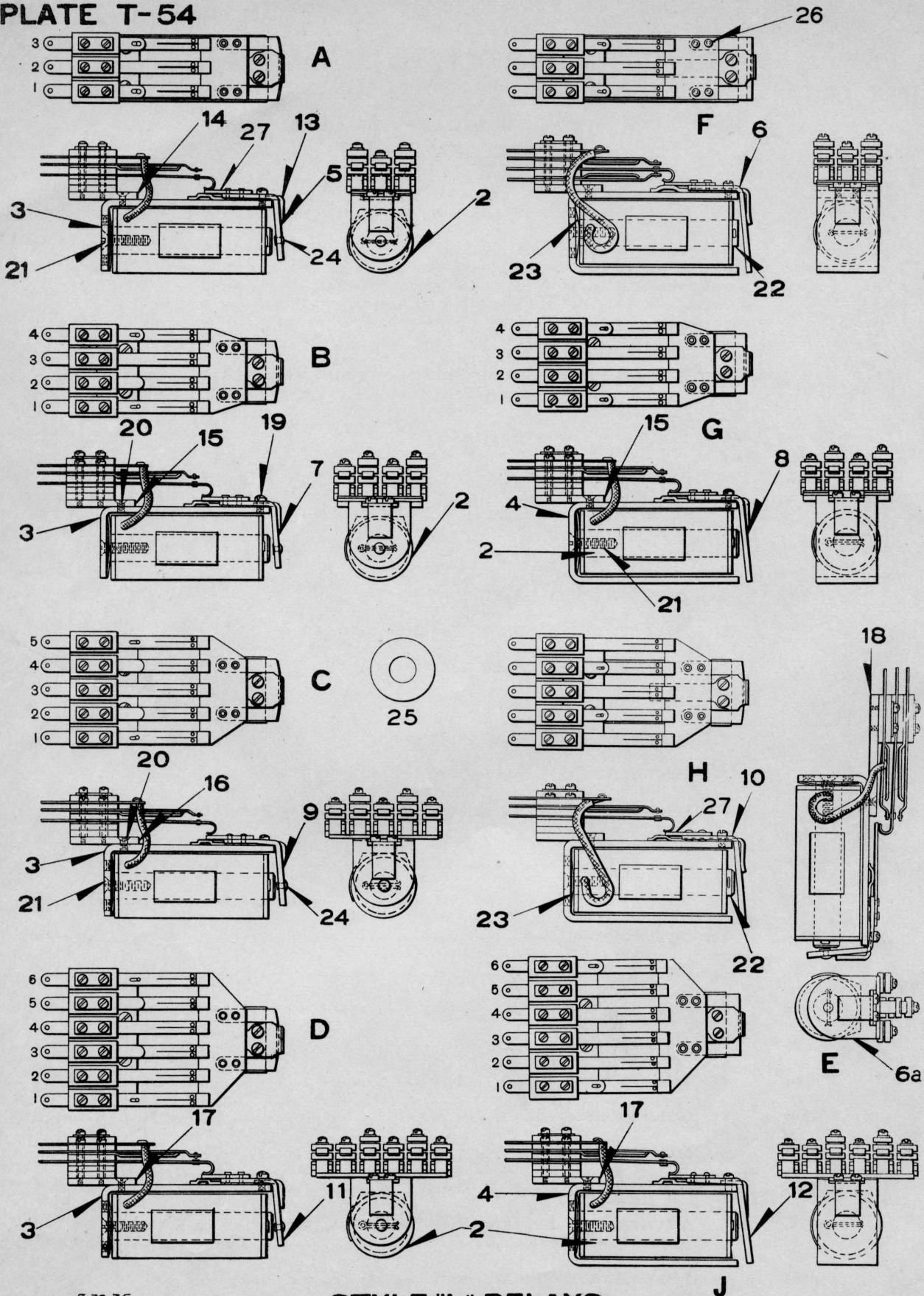

7-30-35  
8-38  
2-15-39

## STYLE "L" RELAYS

# UNION SWITCH & SIGNAL CO.

## CENTRALIZED TRAFFIC CONTROL SYSTEM

### DETAIL PARTS

#### STYLE "L" RELAYS FOR C.T.C. SYSTEM

When ordering replacement relays, give relay nomenclature and the installation for which required. When ordering relays not for replacement state contact and battery requirements. Also state nomenclature required for stamping on Armature. In stating contact requirements specify in terms of assemblies shown on Plate T-55.

Order by Plate, Piece, Reference and Abbreviated Description Given in Heavy Face Type Only EXCEPT AS NOTED ABOVE.

Piece	Ref.	Description	Drawing Reference
	A	3-WAY STYLE "L-1" RELAY	
	B	4-WAY STYLE "L-1" RELAY	
	C	5-WAY STYLE "L-1" RELAY	
	D	6-WAY STYLE "L-1" RELAY	
	E	3-WAY STYLE "L-2" RELAY (Time Code Line Relay)	
	F	3-WAY STYLE "L-3" RELAY (Slow Acting)	
	G	4-WAY STYLE "L-3" RELAY (Slow Acting)	
	H	5-WAY STYLE "L-3" RELAY (Slow Acting)	
	J	6-WAY STYLE "L-3" RELAY (Slow Acting)	
	K	STYLE "L-10" PC RELAY (Mounted in special case for Cable jobs) (Not shown)	
174998	2	COIL, 20-Ohms.....	8133-382
156057	2a	COIL, 31-Ohms.....	8133-382
156056	2b	COIL, 48-Ohms.....	8133-382
152761	2c	COIL, 72-Ohms.....	8133-382
163000	2d	COIL, 112-Ohms.....	8133-382
163001	2e	COIL, 175-Ohms.....	8133-382
152762	2f	COIL, 280-Ohms.....	8133-382
161796	2g	COIL, 450-Ohms.....	8133-382
152757	3	BACKSTRAP for Refs.A, B, C, D and E.....	8162-226
155364	4	BACKSTRAP for Refs.J, F, G and H.....	8162-228
185954	5	3-WAY ARMATURE COMPLETE, with Insulation, Rivets and Core Pin (Core Pin unfiled).....	8157-355
156361	6	3-WAY ARMATURE COMPLETE, with Insulation, and Rivets for Style "L-3" Relays.....	8157-363



# UNION SWITCH & SIGNAL CO.

PIECE	REF.	DESCRIPTION	DWG. REF.
185955	6a	1-WAY ARMATURE COMPLETE, with Ins. and Rivets, for Ref.E (Core Pin unfiled).....	8157-355
185956	7	4-WAY ARMATURE COMPLETE, with Insulation, Rivets and Core Pin (Core Pin unfiled).....	8157-355
161642	8	4-WAY ARMATURE COMPLETE, with Insulation, and Rivets for Style "L-3" Relays.....	8157-363
185957	9	5-WAY ARMATURE COMPLETE, with Insulation, Rivets and Core Pin (Core Pin unfiled).....	8157-355
161970	10	5-WAY ARMATURE COMPLETE, with Insulation, and Rivets for Style "L-3" Relays.....	8157-363
185958	11	6-WAY ARMATURE COMPLETE, with Insulation, Rivets and Core Pin (Core Pin unfiled).....	8157-355
161860	12	6-WAY ARMATURE COMPLETE, with Insulation, and Rivets for Style "L-3" Relays.....	8157-363
152756	13	ARMATURE STOP.....	11893-432
152751	14	3-WAY BASE PLATE.....	11893-434
152752	15	4-WAY BASE PLATE.....	11893-434
152753	16	5-WAY BASE PLATE.....	11893-434
152754	17	6-WAY BASE PLATE.....	11893-434
152755	18	3-WAY BASE PLATE.....	11893-435
	19	MACHINE SCREW, NO.6-40 x 5/32" Fil.Hd.S. (N.P.) for attaching Armature Stop to Backstrap	
	20	MACHINE SCREW, NO.6-40 x 1/4" Flat Hd.S. (N.P.) for attaching Base Plate to Backstrap	
	21	MACHINE SCREW, NO.10-30 x 5/8" Flat Hd.S. (N.P.) for attaching Backstrap to Coil	
161589	22	CORE.....	8101-304
209194	22a	CORE.....	8101-346
183234	22b	CORE.....	8101-359
169124	22c	CORE.....	8101-346
175630	23	WASHER.....	7828-374
	23a	COTTER PIN 1/16" x 3/4" St. N.P.	
54920	24	CORE PIN, for "L-1" Relay type armatures.....	10301-1
209337	25	WASHER, Copper (Used between Washer Ref.23 and Backstrap)(For Chain Relays).....	7828-176
143762	26	EYELET RIVET. For attaching armature bakelite to armature....	12579-2
152741	27	1-WAY ARMATURE BAKELITE.....	8750-2320
152737	27a	3-WAY ARMATURE BAKELITE.....	8750-2321
152738	27b	4-WAY ARMATURE BAKELITE.....	8750-2321
152739	27c	5-WAY ARMATURE BAKELITE.....	8750-2321
152740	27d	6-WAY ARMATURE BAKELITE.....	8750-2321

NOTE:-Ordering references for Contact Springs, Coil Connectors  
and fittings will be found on Plate T-55.

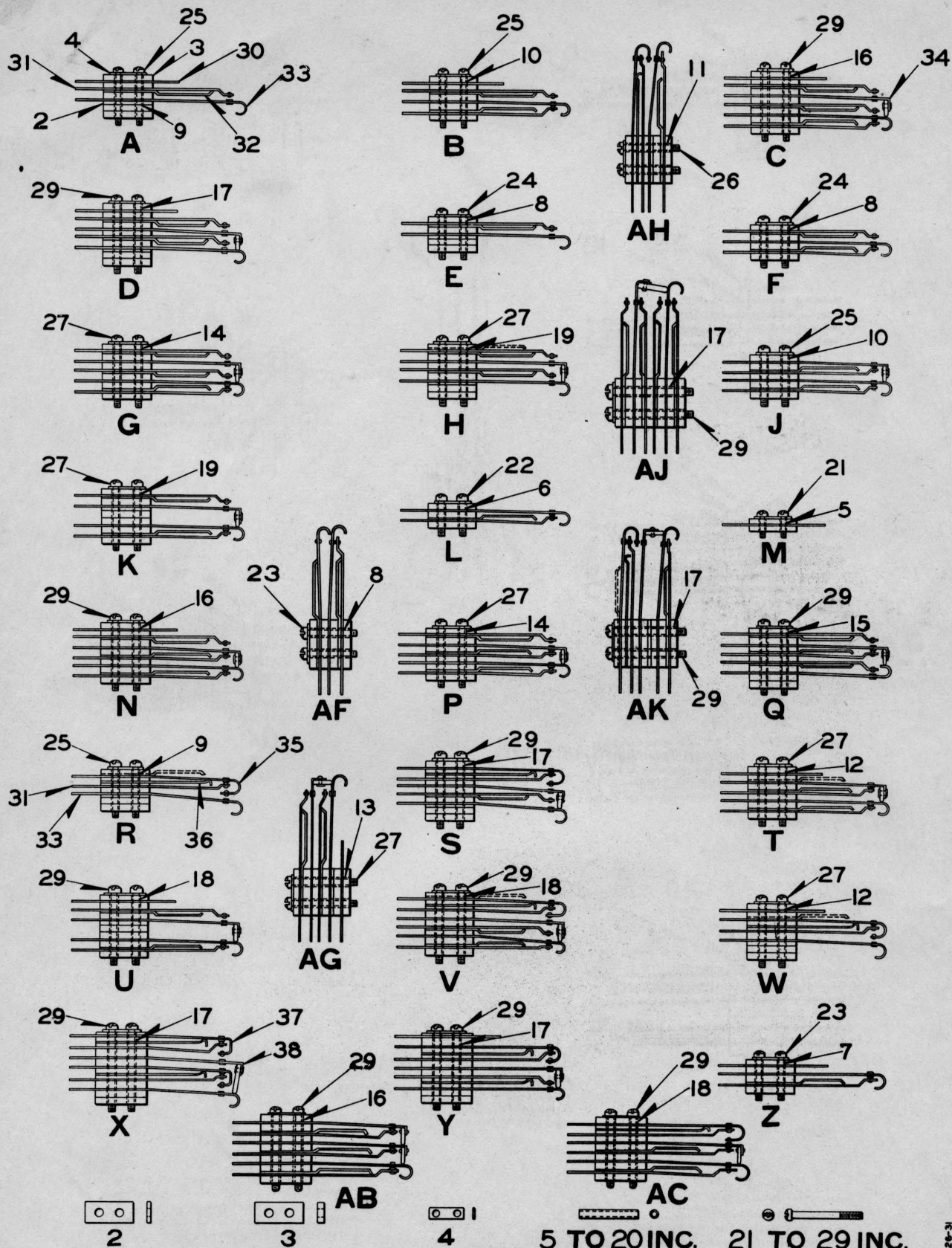

5-28-31



# UNION SWITCH & SIGNAL CO.

# PLATE T-55

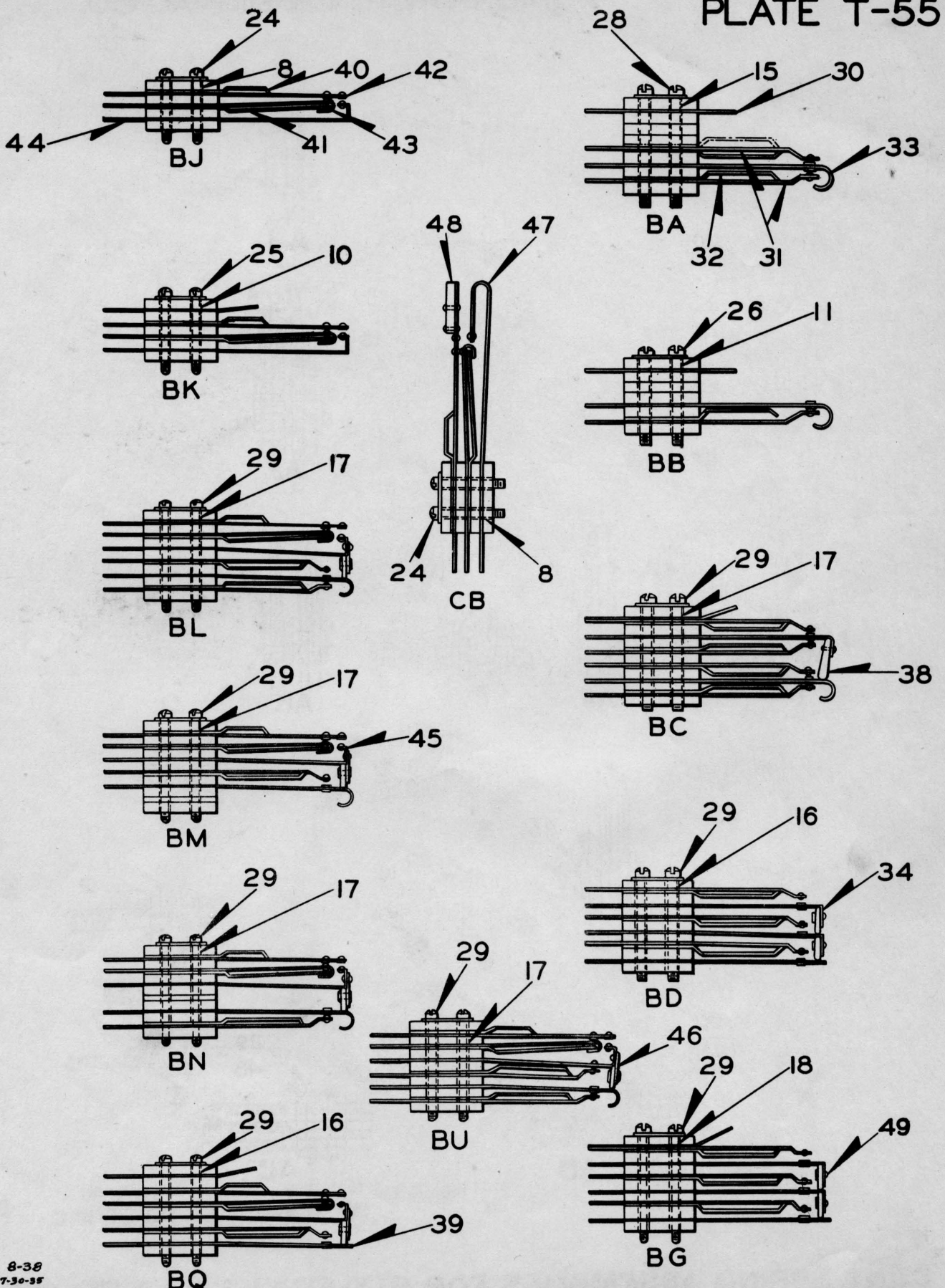

8-38  
7-30-35

CONT. SPR. ASSEM. FOR STYLE L-1, L-2 & L-3 RELAYS

# UNION SWITCH & SIGNAL CO.

## CENTRALIZED TRAFFIC CONTROL SYSTEM

### DETAIL PARTS

CONTACT SPRING DIAGRAMS AND FITTINGS  
FOR STYLE L-1, L-2 AND L-3 RELAYS.

Order by Plate, Piece, Reference and Abbreviated Description Given in  
Heavy Face Type

Piece	Ref.	Description	Drawing Reference
152718	2	INSULATION (1/16" thick).....	8750-1460
174235	3	INSULATION (1/8" thick).....	8750-2035
152720	4	WASHER.....	7828-275
152731	5	INS.BUSHING, length 1/4".....	B-10266-1
152732	6	INS.BUSHING, length 7/16".....	B-10266-1
161846	7	INS.BUSHING, length 37/64".....	B-10266-1
152733	8	INS.BUSHING, length 39/64".....	B-10266-1
152734	9	INS.BUSHING, length 3/4".....	B-10266-1
160279	10	INS.BUSHING, length 49/64".....	B-10266-1
168652	11	INS.BUSHING, length 13/16".....	B-10266-1
160471	12	INS.BUSHING, length 57/64".....	B-10266-1
152735	13	INS.BUSHING, length 59/64".....	B-10266-1
168557	14	INS.BUSHING, length 61/64".....	B-10266-1
169144	15	INS.BUSHING, length 1".....	B-10266-1
160283	16	INS.BUSHING, length 1-3/64".....	B-10266-1
152736	17	INS.BUSHING, length 1-1/16".....	B-10266-1
160299	18	INS.BUSHING, length 1-5/64".....	B-10266-1
175482	19	INS.BUSHING, length 1-7/64".....	B-10266-1
161280	20	INS.BUSHING, length 1-1/8".....	B-10266-1
	21	MACHINE SCREW NO.3-56 x 7/16" Fil.Hd.S.(N.P.)	
	22	MACHINE SCREW NO.3-56 x 5/8" Fil.Hd.S.(N.P.)	
	23	MACHINE SCREW NO.3-56 x 3/4" Fil.Hd.S.(N.P.)	
	24	MACHINE SCREW NO.3-56 x 13/16" Fil.Hd.S.(N.P.)	
	25	MACHINE SCREW NO.3-56 x 15/16" Fil.Hd.S.(N.P.)	



# UNION SWITCH & SIGNAL CO.

PIECE	REF.	DESCRIPTION	DWG. REF.
	26	MACHINE SCREW NO.3-56 x 1" Fil.Hd.S. (N.P.)	
	27	MACHINE SCREW NO.3-56 x 1-1/8" Fil.Hd.S. (N.P.)	
	28	MACHINE SCREW NO.3-56 x 1-3/16" Fil.Hd.S. (N.P.)	
	29	MACHINE SCREW NO.3-56 x 1-1/4" Fil.Hd.S. (N.P.)	
152721	30	COIL CONNECTOR.....	8064-663
152725	31	FRONT OR BACK CONTACT.....	8385-2166
152726	32	CONTACT STOP, also used as Buffer Stop where necessary.....	8385-2166
152728	33	CONTACT FINGER, used where finger rests on Armature.....	8385-2167
152730	34	CONTACT FINGER COMPLETE with Insulation Tip,used in upper row.	8385-2167
160237	35	CONTINUITY CONTACT FINGER.....	8385-2216
163343	36	CONTACT STOP for Continuity Contact.....	8385-2227
161329	37	CONTINUITY CONTACT FINGER.....	8385-2226
161331	38	CONTACT FINGER COMPLETE with Insulation Tip, used above continuity contact.....	8385-2227
173103	39	CONTACT SPRING COMPLETE.....	8385-2290
182145	40	CONTACT SPRING.....	8385-2344
182146	41	CONTACT STOP.....	8385-2345
182148	42	CONTACT SPRING COMPLETE.....	8385-2346
182150	43	CONTACT SPRING COMPLETE.....	8385-2347
182207	44	CONTACT SPRING COMPLETE.....	8385-2348
182153	45	CONTACT SPRING COMPLETE.....	8385-2348
187778	46	CONTACT SPRING COMPLETE.....	8385-2398
101998	47	CONTACT SPRING COMPLETE.....	8385-2532
102000	48	CONTACT SPRING COMPLETE with Weight.....	8385-2533
143761	49	EYELET RIVET for attaching bakelite tips to heel spring.....	12579-2

# UNION SWITCH & SIGNAL CO.

## PLATE T-56

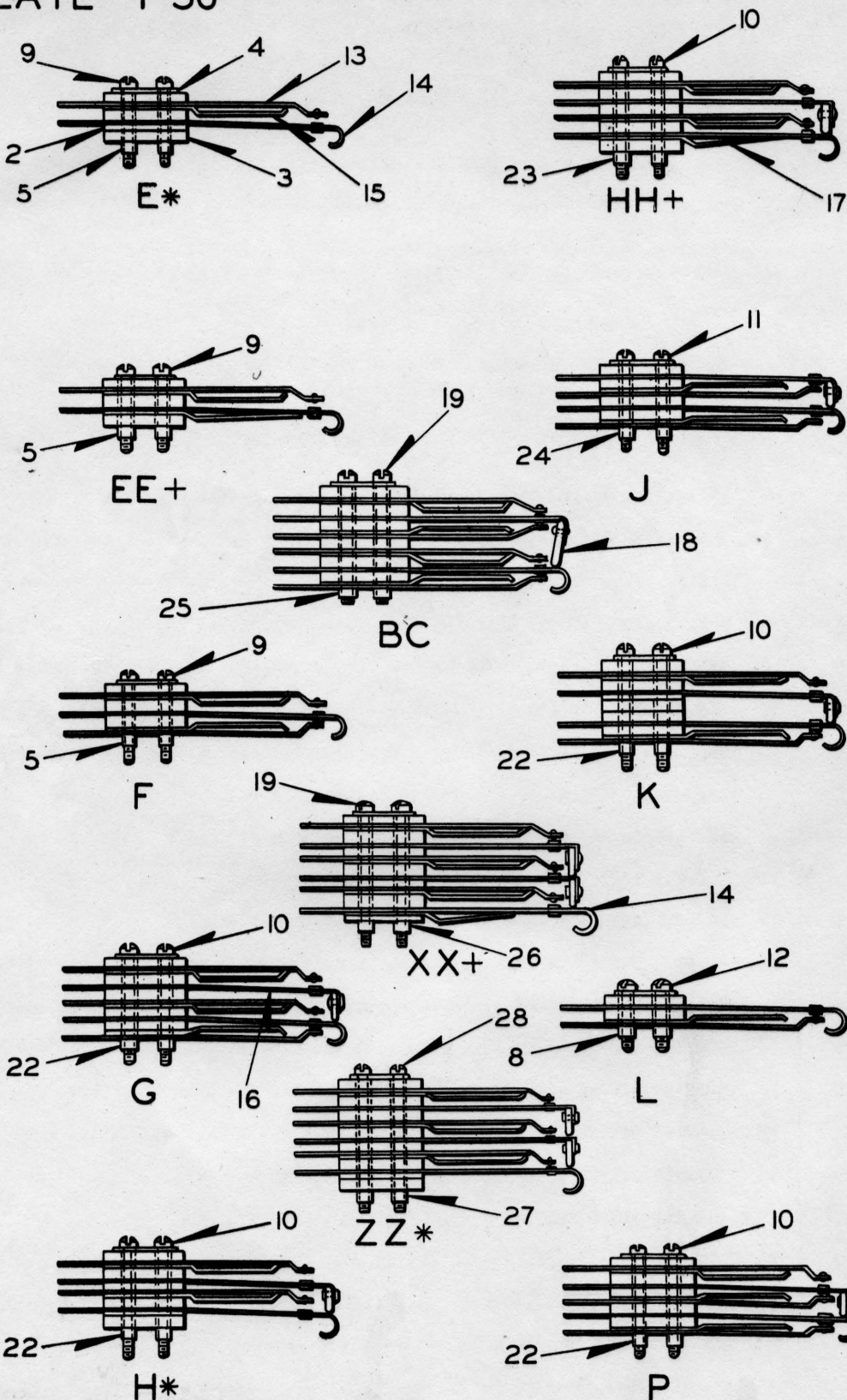

### CONT. SPRING ASSEMBLIES FOR CIR. CONTS.

\*CANNOT BE USED ON CIRCUIT CONTROLLER REF. A, PLATE T-21  
 †CANNOT BE USED ON CIRCUIT CONTROLLERS. REFS. B & C, PLATE T-21



# UNION SWITCH & SIGNAL CO.

## CENTRALIZED TRAFFIC CONTROL SYSTEM

### DETAIL PARTS

#### CONTACT SPRING DIAGRAMS AND FITTINGS FOR SIGNAL LEVER, SWITCH LEVER AND PUSH BUTTON CIRCUIT CONTROLLERS.

Construction of contact assemblies is shown in detail to permit the ordering of assemblies by code letter or the building of assemblies from parts in the field.

#### Order by Plate, Piece, Reference and Abbreviated Description Given in Heavy Face Type

Piece	Ref.	Description	Drawing Reference
152718	2	INSULATION (1/16" thick).....	8750-1460
174235	3	INSULATION (1/8" thick).....	8750-2035
152720	4	WASHER.....	7828-275
152733	5	INS.BUSHING, length 37/64".....	B-10266-1
152735	6	INS.BUSHING, length 59/64".....	B-10266-1
152734	7	INS.BUSHING, length 47/64".....	B-10266-1
152732	8	INS.BUSHING, length 13/32".....	B-10266-1
	9	MACHINE SCREW, NO.3-56 x 13/16" Fil.Hd.S.(N.P.)	
	10	MACHINE SCREW, NO.3-56 x 1-1/8" Fil.Hd.S.(N.P.)	
	11	MACHINE SCREW, NO.3-56 x 15/16" Fil.Hd.S.(N.P.)	
	12	MACHINE SCREW, NO.3-56 x 5/8" Fil.Hd.S.(N.P.)	
152725	13	FRONT OR BACK CONTACT.....	8385-2166
152728	14	CONTACT FINGER, used in lower row.....	8385-2167
152726	15	CONTACT STOP.....	8385-2166
152730	16	CONTACT FINGER COMPLETE with Insulation Tip, used in upper row	8385-2167
166109	17	CONTACT STOP.....	8385-2252
161331	18	CONTACT FINGER COMPLETE with Insulation Tip.....	8385-2227
	19	MACHINE SCREW NO.3-56 x 1-1/4" Fil.Hd.S.(N.P.)	
161280	20	INS.BUSHING, length 1-5/64".....	B-10266-1
173103	21	CONTACT FINGER.....	8385-2290
168557	22	INS.BUSHING, length 57/64".....	B-10266-1
160471	23	INS.BUSHING, length 55/64".....	B-10266-1
160279	24	INS.BUSHING, length 23/32".....	B-10266-1
152736	25	INS.BUSHING, length 1-3/64".....	B-10266-1

# UNION SWITCH & SIGNAL CO.

PIECE	REF.	DESCRIPTION	DWG. REF.
183766	26	INS.BUSHING, length 1-1/8".....	B-10266-1
173926	27	INS.BUSHING, length 1-13/64".....	B-10266-1
	28	MACHINE SCREW, NO. 3-56 x 1-7/16" Fil. Hd. S. (N.P.)	
5-32			



# UNION SWITCH & SIGNAL CO.

## PLATE T-60

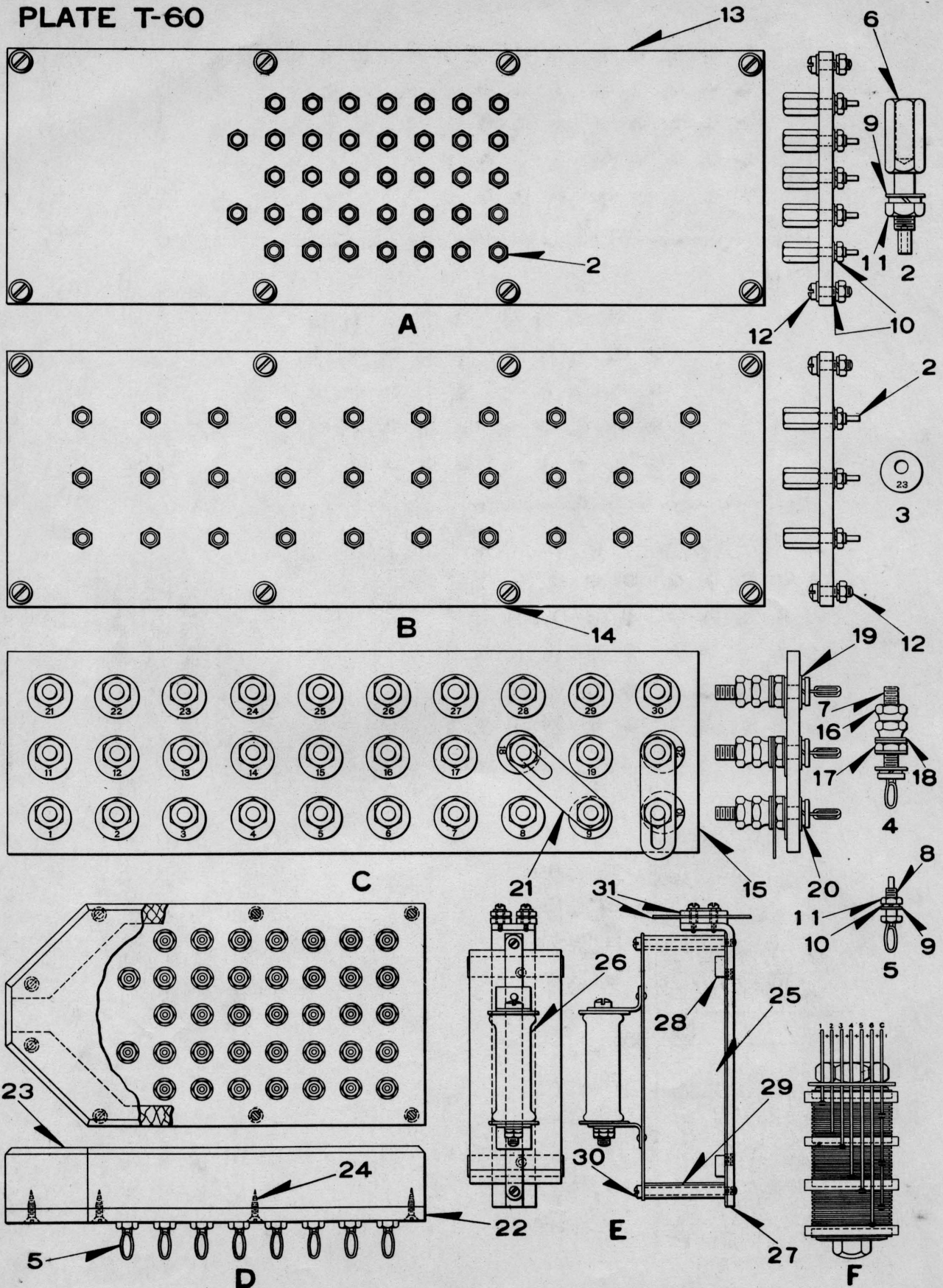

TERMINAL BOARDS, PLUG CONNECTORS, ETC.

# UNION SWITCH & SIGNAL CO.

PLATE T-60

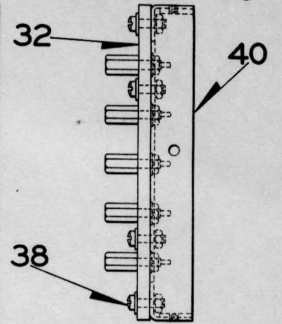
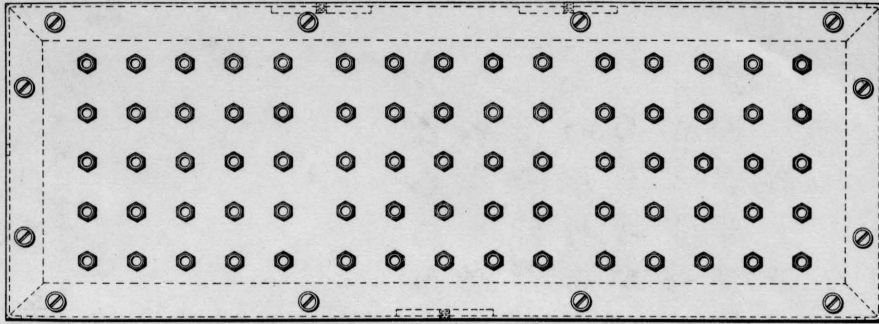

H

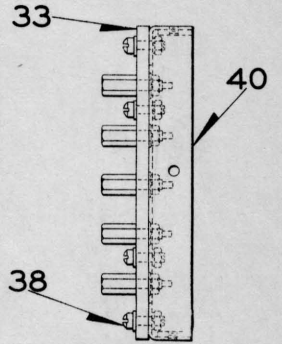
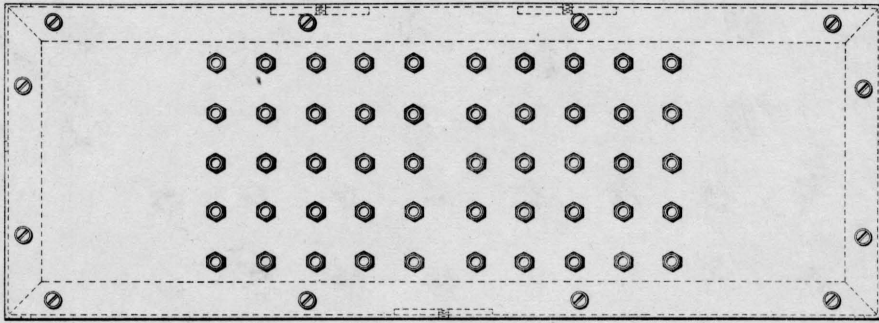

J

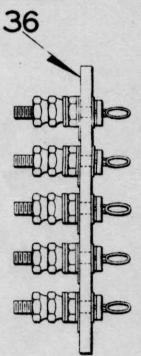
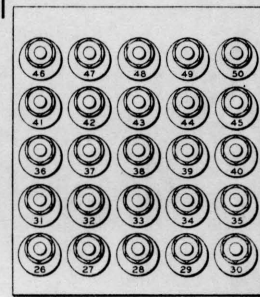
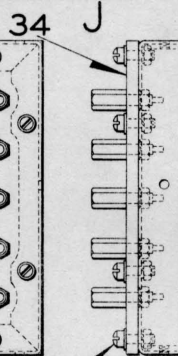
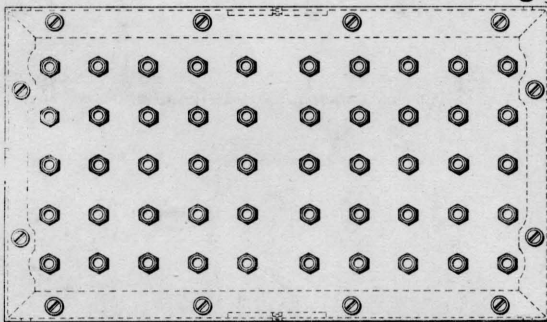

35 K

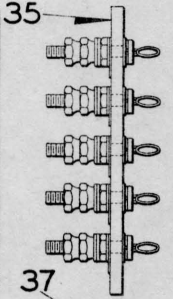
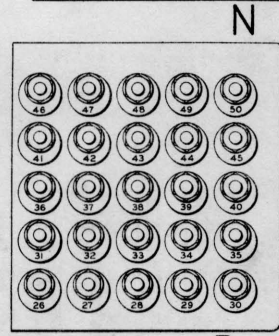
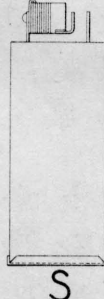
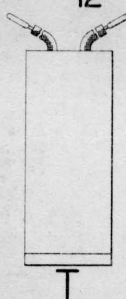
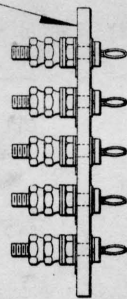
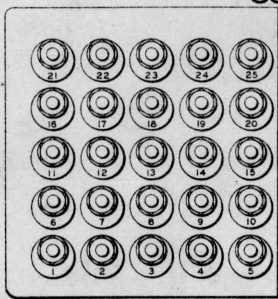

M

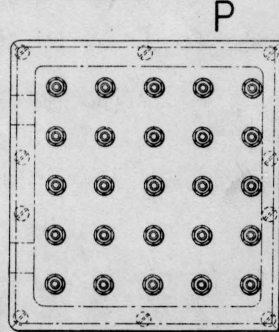
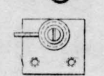
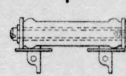
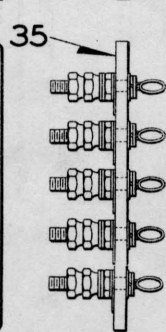
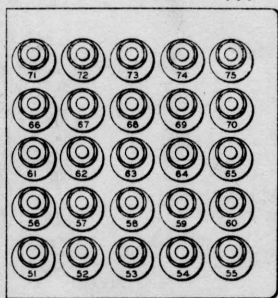

43

Q

42

G

R

TERMINAL BOARDS, PLUG CONNECTORS, ETC.



# UNION SWITCH & SIGNAL CO.

## CENTRALIZED TRAFFIC CONTROL SYSTEM

### DETAIL PARTS

#### TIME CODE SYSTEM

#### TERMINAL BOARDS, PLUG CONNECTORS & RECTIFIERS FOR OFFICE AND FIELD STATION CONTROL UNITS

When ordering for replacement, state  
installation for which required.

**Order by Plate, Piece, Reference and Abbreviated Description Given in  
Heavy Face Type Only**

PIECE	REF.	DESCRIPTION	DWG. REF.
154549	A	TERMINAL BOARD COMPLETE with thirty-seven Sockets and eight Screws Ref.12 for Office Control Unit (12 Station Basis).....	C-9232-7
154467	B	TERMINAL BOARD COMPLETE with thirty Sockets and eight Screws Ref.12 for Field Station Control Unit (12 Station Basis).....	C-9232-5
154489	C	PLUG CONNECTOR COMPLETE with thirty Plugs for Field Station Control Unit Ref.B.....	C-9232-6
154747	D	PLUG CONNECTOR COMPLETE with thirty-seven Plugs for Office Control Unit Ref.A.....	C-9232-9
158913	E	SPARK ARRESTER UNIT COMPLETE, with 1 MF Condenser, 90-ohm Resistor and Fittings.....	C-9232-9
152430	F	TYPE RS-18 RECTIFIER COMPLETE (Ref. D, Plate S-606).....	12558-13
173178	G	TYPE RS-7 RECTIFIER COMPLETE (Ref. Ba, Plate S-606).....	12558-18
173183	H	TERMINAL BOARD COMPLETE with seventy-five Sockets for Field L-C-S Unit (Without Cover Ref.40) (35 Station Basis).....	C-9232-47
173244	Ha	TERMINAL BOARD COMPLETE with Cover Ref.40 and Seventy-five Sockets for Field L-C-S Unit (35 Station Basis).....	C-9232-47
101925	Hb	TERMINAL BOARD COMPLETE with eighty Sockets for Field L-C-S Unit (without Cover) (35 Station Biased Polar Line Circuit).....	C-9232-105
173186	J	TERMINAL BOARD COMPLETE with fifty Sockets, for Office L-C Unit (without Cover Ref.41) (35 Station Basis).....	C-9232-44
173187	Ja	TERMINAL BOARD COMPLETE with Cover Ref.41 and fifty Sockets for Office L-C Unit (35 Station Basis).....	C-9232-44
173234	K	TERMINAL BOARD COMPLETE with fifty Sockets for Field Storage Unit (without Cover Ref.42) (35 Station Basis).....	C-9232-48
173235	Ka	TERMINAL BOARD COMPLETE with Cover Ref.42 and fifty Sockets, for Field Storage Unit (35 Station Basis).....	C-9232-48
173240	M	L.H. PLUG CONNECTOR COMPLETE with twenty-five contact springs and terminal posts for Field L-C-S and Field Storage Units (35 Station Basis).....	C-9232-51
184690	Ma	L.H. PLUG CONNECTOR COMPLETE with twenty-five contact springs and terminal posts for Field L-C-S and Field Storage Units (35 Station Biased Polar Line Circuit).....	C-9232-51
173242	N	MIDDLE PLUG CONNECTOR COMPLETE with twenty-five Contact Springs and Terminal Posts for Field L-C-S Unit (35 Station Basis).....	C-9232-51
184689	Na	MIDDLE PLUG CONNECTOR COMPLETE with twenty-five Contact Springs and Terminal Posts for Field L-C-S Unit (35 Station Biased Polar Line Circuit).....	C-9232-51
173246	P	R.H. PLUG CONNECTOR COMPLETE, with twenty-five Contact Springs and Terminal Posts, for Field Storage Unit (35 Station Basis).	C-9232-51

# UNION SWITCH & SIGNAL CO.

PIECE	REF.	DESCRIPTION	DWG. REF.
184691	Pa	R.H. PLUG CONNECTOR COMPLETE, with twenty-five Contact Springs and Terminal Posts, for Field Storage Unit (35 Station Biased Polar Line Circuit).....	C-9232-51
173219	Q	R.H. PLUG CONNECTOR COMPLETE with twenty-five Contact Springs and Terminal Posts, for Field Coding Unit (35-Station Basis)..	C-9232-45
101931	Qa	R.H. PLUG CONNECTOR COMPLETE with thirty Contact Springs and Terminal Posts, for Field L-C-S Unit (35 Station Biased Polar Line Circuit).....	C-9232-105
173236	R	OFFICE PLUG CONNECTOR COMPLETE with Cover and twenty-five Contact Springs and Terminal Posts, for Office Unit (35 Station Basis).....	C-9232-45
173221	Ra	OFFICE PLUG CONNECTOR COMPLETE (with twenty-five Contact Springs and Terminal Posts (Without Cover) for Office Unit (35 Station Basis).....	C-9232-45
173134	S	CONDENSER (0.5 MF.) COMPLETE with 5-ohm Resistor.....	C-9232-3
168916	Sa	CONDENSER (0.5 MF.) Without Resistor.....	B-12549-15
169608	T	CONDENSER (1.0 MF.) COMPLETE with Leads.....	B-12549-15
	2	SOCKET, COMPLETE with Nut, Washer and Lock Washer for Refs.A, B, H, J and K.	
142777	3	WHITE CELLULOID TAG (orders should specify marking required)..	8988-75
	4	CONTACT SPRING AND TERMINAL POST, COMPLETE with Nuts, Washers and Lock Washers for Refs.C, M, N, P and Q.	
	5	CONTACT SPRING AND TERMINAL POST, COMPLETE with Nuts, Washer and Lock Washer for Refs.D and R.	
153972	6	SOCKET ONLY for Ref.2.....	8094-2220
154506	7	CONTACT SPRING AND TERMINAL POST ONLY for Ref.4.....	8385-2174
154591	8	CONTACT SPRING AND TERMINAL POST ONLY for Ref.5.....	8385-2181
44618	9	WASHER ONLY, for Ref.2.....	7828-184
	10	LOCK WASHER 3/16" Plain S. (3/32" x 1/32") N.P. for Ref.2	
26942	11	HEX.NUT ONLY for Ref.2.....	8109-184
	12	MACHINE SCREW NO.10-30 x 5/8" Fil.Hd.S.(N.P.) with Washer Ref. 9, Lock Washer Ref.10 and Hex.Nut Ref.12a for attaching Terminal Boards Refs.A and B to cover.	
73488	12a	HEX.NUT for Ref.12.....	8265-111
154548	13	TERMINAL BOARD ONLY for Ref.A.....	C-9232-7
152708	14	TERMINAL BOARD ONLY for Ref.B.....	C-9232-5
154488	15	TERMINAL BOARD ONLY for Ref.C.....	C-9232-6
29101	16	HEX.NUT ONLY for Ref.4.....	8109-193
29103	17	HEX.NUT ONLY for Ref.4.....	8109-194
29102	18	WASHER ONLY for Ref.4.....	7828-139
29104	19	WASHER ONLY for Ref.4.....	7828-138
	20	LOCK WASHER 1/4" Plain S. (1/8" x 1/16") N.P. for Ref.4	
158901	21	TERMINAL CONNECTOR ONLY for Ref.C.....	8064-677
154594	22	PLUG CONNECTOR BOARD COMPLETE with thirty-seven Plugs for Ref.D.....	C-9232-8



# UNION SWITCH & SIGNAL CO.

PIECE	REF.	DESCRIPTION	DWG. REF.
154592	22a	TERMINAL BOARD ONLY for Ref.22.....	C-9232-8
154593	23	COVER ONLY for Ref.D.....	C-9232-8
	24	WOOD SCREW NO.6 x 5/8" Flat Hd.Br. (N.P.) for attaching Cover Ref.23 to Board Ref.22	
135177	25	CONDENSER 1 M.F. for Ref.E.....	B-12549-2
155216	26	RESISTOR 90-ohms for Ref.E.....	9065-200
155238	27	CONDENSER PLATE for Ref.E.....	9999-641
136811	28	CLIP for Ref.E.....	11893-291
116612	29	SLEEVE for Ref.E.....	8350-513
63803	30	SCREW for Ref.E.....	8098-1275
	31	TERMINAL CONNECTOR, COMPLETE with Screws, Insulations, Bushings and Washer (For details refer to Plate T-55, Ref.M)	
173182	32	TERMINAL BOARD ONLY, for Refs.H and Ha.....	C-9232-47
173185	33	TERMINAL BOARD ONLY, for Refs.J and Ja.....	C-9232-44
173233	34	TERMINAL BOARD ONLY, for Refs.K and Ka.....	C-9232-48
173218	35	TERMINAL BOARD ONLY, for Refs.M, P and Q.....	C-9232-45
173241	36	TERMINAL BOARD ONLY, for Ref.N.....	C-9232-51
173220	37	TERMINAL BOARD ONLY, for Ref.R.....	C-9232-45
	38	MACHINE SCREW, NO.10-30 x 5/8" Fil.Hd.S.(N.P.) with Nut Ref. 38a, Washer Ref.38b and 3/16" Plain S.Lock Washer (3/32" x 1/32") (N.P.)	
52727	38a	NUT ONLY, for Ref.38.....	8265-126
44618	38b	WASHER ONLY, for Ref.38.....	7828-184
173190	39	COVER, for Ref.R.....	C-9232-46
173189	40	COVER COMPLETE for Refs.Ha and Ja.....	C-9232-43
173243	41	COVER COMPLETE for Ref.Ka.....	C-9232-49
	42	RESISTOR UNIT ASSEMBLY arranged for Six Resistors, complete with Support Bracket and Insulating Strips.....	9065-226
102993	43	RESISTANCE UNIT COMPLETE (31 Ohms).....	9065-276
	44	RESISTOR, 500-Ohms (Soldered directly to coil connector terminals of G relay in Field L-C-S unit and GP relay in Office L-C unit) (Not shown)	

# UNION SWITCH & SIGNAL CO.

## PLATE T-62

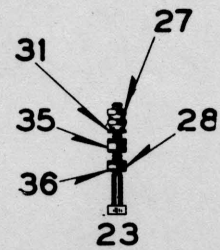
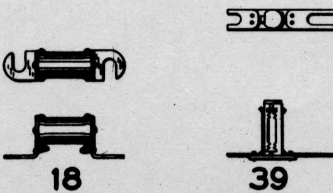
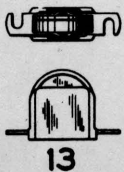
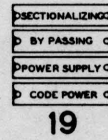
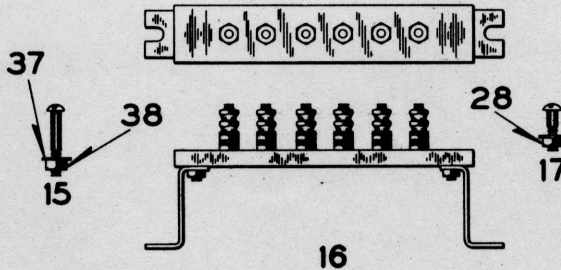
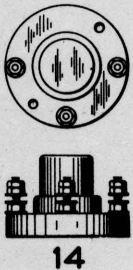
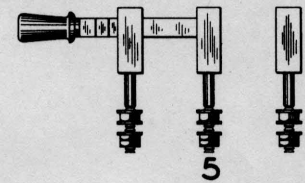
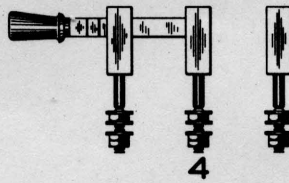
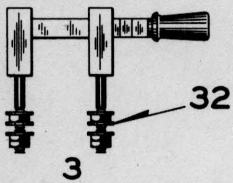
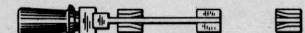
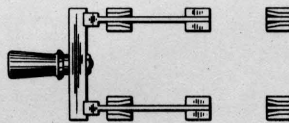
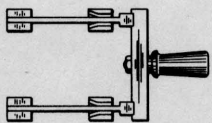
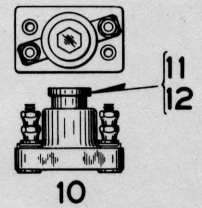
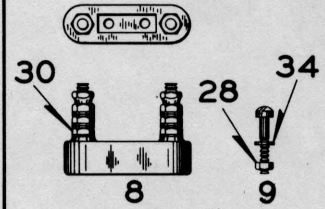
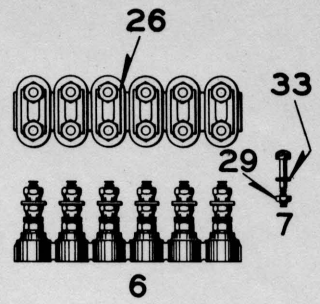
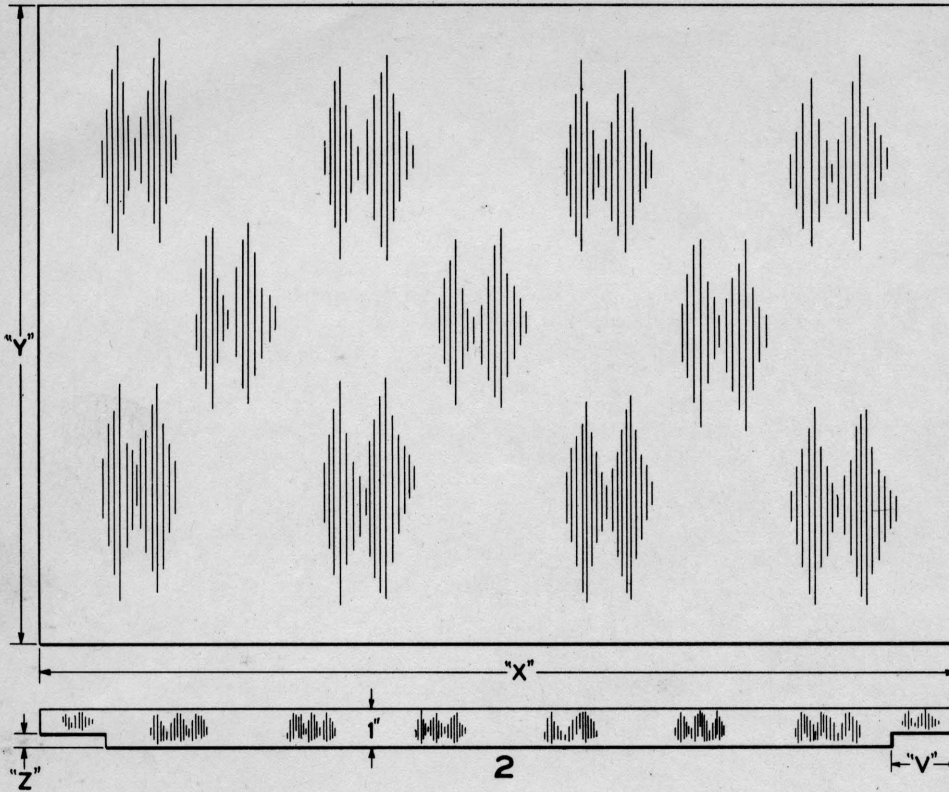



# UNION SWITCH & SIGNAL CO.

CENTRALIZED TRAFFIC CONTROL SYSTEM

DETAIL PARTS

TIME CODE SYSTEM

SWITCHBOARDS, RESISTORS, SWITCHES, ETC.

When ordering for replacement, state installation for which required.

**Order by Plate, Piece, Reference and Abbreviated Description Given in Heavy Face Type Only**

PIECE	REF.	DESCRIPTION	DWG. REF.
	2	SWITCHBOARD (Undrilled)(Orders should state "v", "x", "y" and "z" dimensions).....	C-9401-
	3	KNIFE SWITCH, TWO POLE SINGLE THROW (30-Amperes, 250-Volts D.C.)	
	4	KNIFE SWITCH, TWO POLE DOUBLE THROW (30-Amperes, 250-Volts D.C.)	
	5	KNIFE SWITCH, SINGLE POLE DOUBLE THROW (30-Amperes, 250-Volts D.C.)	
	6	MULTIPLE UNIT BAKELITE TERMINAL BLOCK (6-Way) with Nuts, Washers and Connectors (Inc.1-6f, 6-26, 24-27, 12-30 and 36-31).....	9968-
	6a	MULTIPLE UNIT BAKELITE TERMINAL BLOCK (5-Way) with Nuts, Washers and Connectors (Inc.1-6g, 5-26, 20-27, 10-30 and 30-31).....	9968-
	6b	MULTIPLE UNIT BAKELITE TERMINAL BLOCK (4-Way) with Nuts, Washers and Connectors (Inc.1-6h, 4-26, 16-27, 8-30 and 24-31)	9968-
	6c	MULTIPLE UNIT BAKELITE TERMINAL BLOCK (3-Way) with Nuts, Washers and Connectors (Inc.1-6j, 3-26, 12-27, 6-30 and 18-31)	9968-
	6d	MULTIPLE UNIT BAKELITE TERMINAL BLOCK (2-Way) with Nuts, Washers and Connectors (Inc.1-6k, 2-26, 8-27, 4-30 and 12-31).	9968-
	6e	MULTIPLE UNIT BAKELITE TERMINAL BLOCK (1-Way) with Nuts, Washers and Connector (Inc.1-6m, 1-26, 4-27, 2-30 and 6-31)...	9968-
178388	6f	MULTIPLE UNIT BAKELITE TERMINAL BLOCK (6-Way) without Nuts, Washers and Connectors.....	9968-1074
181819	6g	MULTIPLE UNIT BAKELITE TERMINAL BLOCK (5-Way) without Nuts, Washers and Connectors.....	9968-1100
181829	6h	MULTIPLE UNIT BAKELITE TERMINAL BLOCK (4-Way) without Nuts, Washers and Connectors.....	9968-1100
181830	6j	MULTIPLE UNIT BAKELITE TERMINAL BLOCK (3-Way) without Nuts, Washers and Connectors.....	9968-1100
181831	6k	MULTIPLE UNIT BAKELITE TERMINAL BLOCK (2-Way) without Nuts, Washers and Connectors.....	9968-1100
181832	6m	MULTIPLE UNIT BAKELITE TERMINAL BLOCK (1-Way) without Nuts, Washers and Connectors.....	9968-1100
	7	MACHINE SCREW, NO.10-30 x 1-1/4" Fil.Hd.Br. (N.P.) with Washer Ref.33 and Nut Ref.29. For attaching Multiple Unit Terminal Block Refs.6 to 6m and Lamp Socket Ref.10 to Board when Board is cbr. 5/16"	
170501	8	BAKELITE TERMINAL BLOCK with Nuts and Washers (Inc.1-8b, 4-27, 2-30 and 6-31).....	9968-1030

# UNION SWITCH & SIGNAL CO.

PIECE	REF.	DESCRIPTION	DWG. REF.	
170363	8a	BAKELITE TERMINAL BLOCK with Nuts and Washers (Inc.1-8b, 2-27, 4-28, 2-30 and 10-31).....	9968-	
	8b	BAKELITE TERMINAL BLOCK without Nuts and Washers.....	9968-1030	
121591	9	MACHINE SCREW, NO.14-24 x 1-1/2" Fil.Hd.Br. (N.P.) with Washer Ref.34 and Nut Ref.28. For attaching Terminal Blocks to Board when Board is cbr. 5/16"		
	10	LAMP SOCKET (Without Adapter Ref.11 and Plug Ref.12).....	9954-60	
	11	ADAPTER for Plug Ref.12 (C.N.70077)		
	12	PLUG, 6.25 Amp. (C.N.71031)		
	13	LIGHTNING ARRESTER COMPLETE (30 to 150 Volts) (C.N.71214)		
	14	LIGHTNING ARRESTER COMPLETE (C.N.70069)		
	15	MACHINE SCREW, NO.10-30 x 1-5/8" Rd.Hd.Br.(N.P.) with Washer Ref.37 and Nut Ref.38. For attaching Lightning Arrester Ref.14 to Board when Board is cbr. 5/16"		
	16	RESISTOR, Type SR-31A-21, 1550-Ohms (50, 100, 200, 400 and 800-Ohms)		
	16a	RESISTOR, Type SU-21A-45, 600-Ohms (100, 200 and 300-Ohms)		
	16b	RESISTOR, Type SU-21A-26, 60-Ohms		
	17	MACHINE SCREW, NO.14-24 x 1-1/8" Rd.Hd.Br. (N.P.) with Washer Ref.34 and Nut Ref.28. For attaching Resistors Refs.16, 16a and 16b to Board when Board is cbr. 5/16"		
	155074	18	RESISTANCE UNIT, 20-Ohms.....	9065-227
	155438	18a	RESISTANCE UNIT, 120-Ohms.....	9065-227
	181068	19	NAME PLATE, Four Pieces (Lettered "Sectionalizing", "By Passing", "Power Supply", "Code Power").....	8225-417
187578	19a	NAME PLATE (Lettered "Cut Out East").....	8225-462	
187579	19b	NAME PLATE (Lettered "Cut Out West").....	8225-462	
	20	SCREW, NO.6 x 3/8" Rd.Hd.Hardened (Cad.Pl.) for attaching Name Plates to Board		
61337	21	TERMINAL CONNECTOR (Copper No.20 B.& S. Gauge, N.P.) "w" dim. 1-1/8", 1/4" holes.....	8064-396	
61336	21a	TERMINAL CONNECTOR (Copper No.20 B.& S. Gauge, N.P.) "w" dim. 1-3/8", 5/16" holes.....	8064-406	
208360	21b	TERMINAL CONNECTOR (Ph.Bz.No.23 B.& S. Gauge, N.P.) "w" dim. 1-3/4", 1/4" holes.....	8064-396	
81048	21c	TERMINAL CONNECTOR (Copper No.20 B.& S. Gauge, N.P.) "w" dim. 1-13/16", 1/4" holes.....	8064-396	
137335	21d	TERMINAL CONNECTOR (Ph.Bz.No.23 B.& S. Gauge, N.P.) "w" dim. 2", 1/4" holes.....	8064-396	
98893	21e	TERMINAL CONNECTOR (Copper No.10 B.& S. Gauge, N.P.) "w" dim. 2", 1/4" holes.....	8064-396	
132680	21f	TERMINAL CONNECTOR (Copper No.22 B.& S. Gauge, N.P.) "w" dim. 3-21/64", 1/4" holes.....	8064-396	
147969	21g	TERMINAL CONNECTOR (Copper No.22 B.& S. Gauge, N.P.) "w" dim. 4-1/16", 1/4" holes.....	8064-396	
179932	22	TAG (Black Fibre, 1/16" x 3/4" x 15/16" with 17/64" Hole) (Orders should specify marking desired).....	8988-8	



# UNION SWITCH & SIGNAL CO.

PIECE	REF.	DESCRIPTION	DWG. REF.
	23	TERMINAL POST with Nuts and Washers (Inc.1-23b, 2-27, 4-31, 1-28, 1-35 and 1-36) (Used when Board is cbr. 1/8").....	12451-
	23a	TERMINAL POST with Nuts and Washers (Inc.1-23c, 2-27, 4-31, 1-28, 1-35 and 1-36) (Used when Board is cbr. 3/32").....	12451-
131237	23b	TERMINAL POST ONLY, 2-3/4" long (Having head 3/8" sq. x 3/16" thick).....	8094-1192
54080	23c	TERMINAL POST ONLY, 2-11/16" long (Having head 1/2" sq. x 3/32" thick).....	8094-797
	24	TWO WIRE CLEAT (C.N.70500) (Not shown)	
	24a	THREE WIRE CLEAT (C.N.70504)	
	24b	SIX WIRE CLEAT (C.N.70506)	
	25	SCREW, NO.10 x 1/2" Rd.Hd.Hardened (Cad.Pl.) For attaching Cleat to Board (Not shown)	
56224	26	TERMINAL CONNECTOR.....	8064-348
29101	27	NUT.....	8109-193
29103	28	NUT.....	8109-194
26942	29	NUT.....	8109-184
127260	30	NUT.....	8109-194
29102	31	WASHER.....	7828-139
183633	32	WASHER.....	7828-376
410164	33	WASHER	
939	34	WASHER.....	7828-7
31670	35	NUT.....	8109-218
29104	36	WASHER.....	7828-138
12162	37	WASHER.....	7828-56
50629	38	NUT.....	8109-299
	39	LIGHTNING ARRESTER COMPLETE	

# UNION SWITCH & SIGNAL CO.

## PLATE T-65

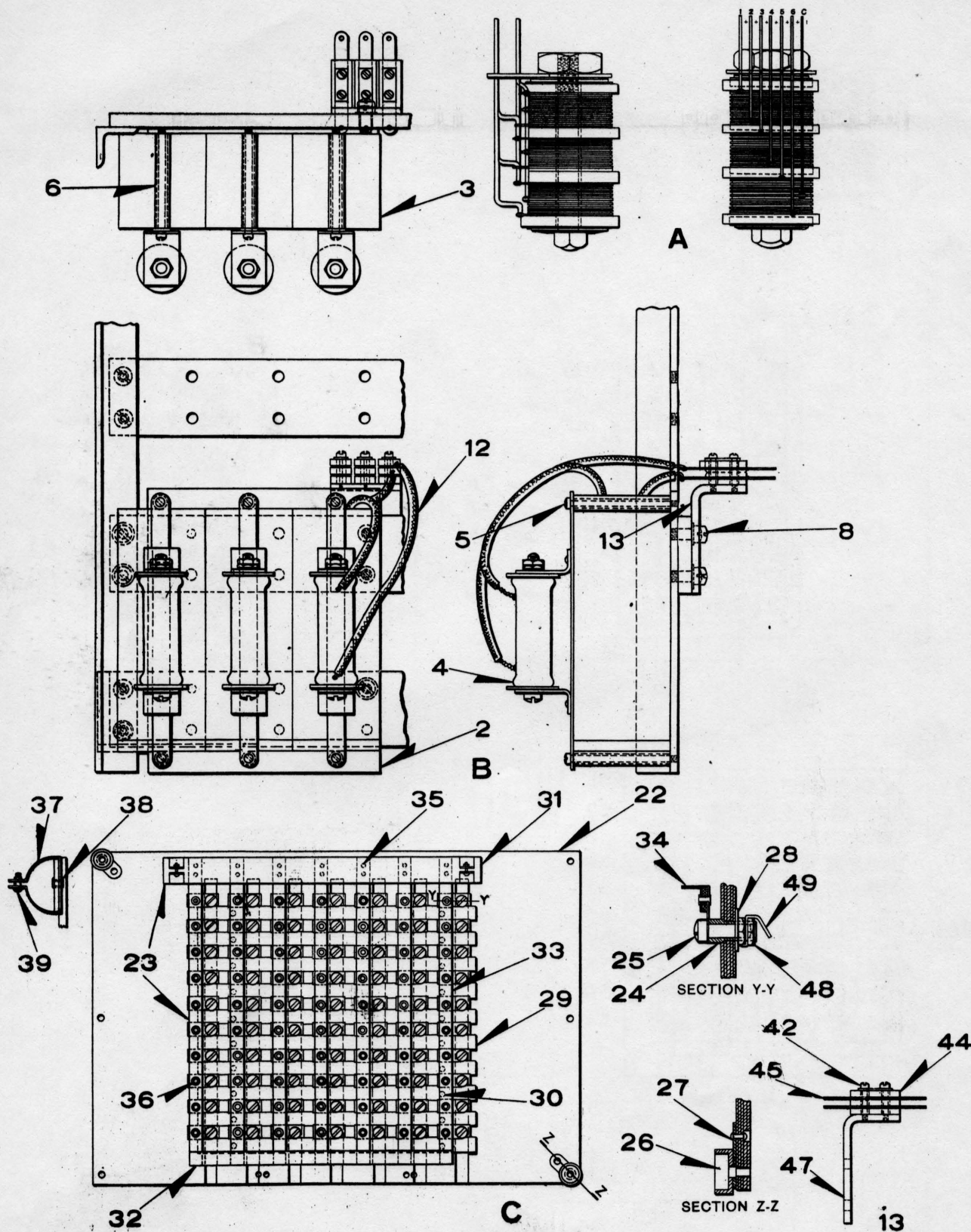

TERMINAL BOARDS, CONDENSERS, RESISTORS ETC



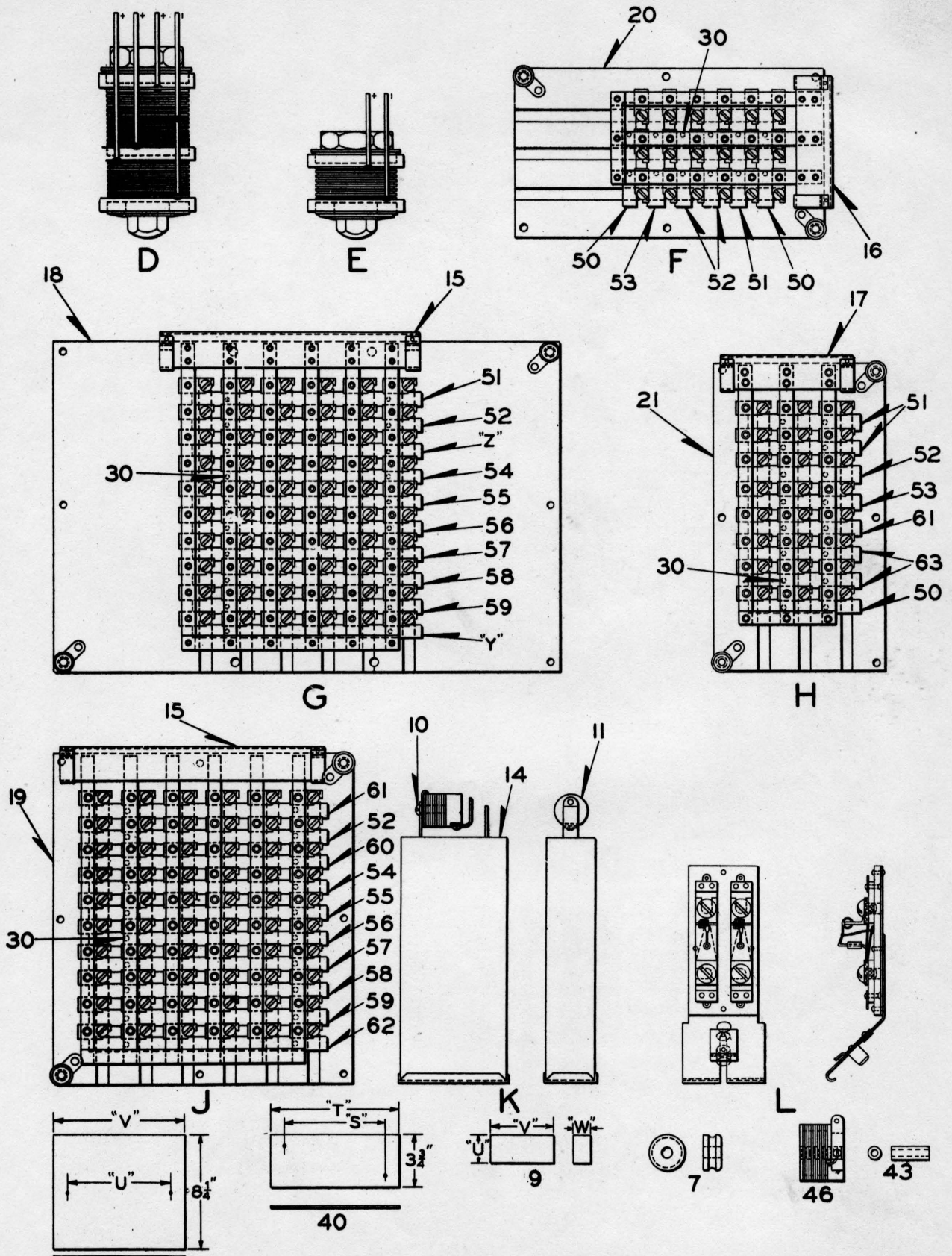

41  
TERMINAL BOARDS, CONDS., RESISTORS, ETC.

# UNION SWITCH & SIGNAL CO.

## CENTRALIZED TRAFFIC CONTROL SYSTEM

### DETAIL PARTS

#### CIRCUIT CODE SYSTEM

#### TERMINAL BOARDS, CONDENSERS, RESISTORS, ETC.

When ordering for replacement state installation for which required.

Order by Plate, Piece, Reference and Abbreviated Description Given in Heavy Face Type

Piece	Ref.	Description	Drawing Reference
152430	A	TYPE RS-18 RECTIFIER COMPLETE (Ref. D, of Plate S-606).....	12558-13
163834	B	CONDENSER AND RESISTOR COMPLETE, with three condensers Ref.3 and three resistors Ref.4 (Does not include Refs.8, 12 and 13) used in office Coding Unit.....	C-9232-14
163983	Ba	CONDENSER AND RESISTOR COMPLETE, with two condensers Ref.3 and two resistors Ref.4 (Does not include Refs.8, 12 and 13) used in field coding unit.....	C-9232-15
161400	C	TERMINAL BOARD COMPLETE, with seventy Terminal Posts, Nuts, Washers and Lock Washers.....	C-9232-10
168944	D	STYLE RS-10 RECTIFIER COMPLETE (Ref. C, of Plate S-606).....	12558-15
168945	E	STYLE RS-2 RECTIFIER COMPLETE (Ref. B, of Plate S-606).....	12558-16
168841	F	TERMINAL BOARD COMPLETE, with eighteen Terminal Posts, Nuts, Washers and Lock Washers (Without Terminal Rack) for Office Line Unit.....	C-9232-32
168921	G	TERMINAL BOARD COMPLETE, with sixty Terminal Posts, Nuts, Washers, and Lock Washers (Without Terminal Rack) for Office Code Unit (Marker Strip "Z" Ref.61) (Marker Strip "Y" Ref.62).	C-9232-32
168839	Ga	TERMINAL BOARD COMPLETE, with sixty Terminal Posts, Nuts, Washers, and Lock Washers, for Field Coding Unit (Marker Strip "Z" Ref.60 and "Y" Ref.53).....	C-9232-32
168840	H	TERMINAL BOARD COMPLETE, with twenty-four Terminal Posts, Nuts, Washers, and Lock Washers (Without Terminal Rack) for Field Line Unit.....	C-9232-32
168429	J	TERMINAL BOARD COMPLETE, with sixty Terminal Posts, Nuts, Washers and Lock Washers (Without Terminal Rack) for Field Storage Unit.....	C-9232-21
173134	K	CONDENSER AND RESISTOR COMPLETE.....	C-9232-3
169220	L	FUSE AND BLOCK COMPLETE with 1-1/3 Amp. Fuse.....	9065-219
	La	FUSE ONLY for Ref. L (1-1/3 Amp.).....	9014-27
163835	2	PLATE for Ref. B.....	9999-747
163982	2a	PLATE for Ref. Ba.....	9999-735
135177	3	CONDENSER.....	B-12549-2



## UNION SWITCH &amp; SIGNAL CO.

PIECE	REF.	DESCRIPTION	DWG. REF.
164642	4	RESISTOR for Ref.B.....	9065-200
164640	4a	RESISTOR for Ref.Ba.....	9065-200
163832	5	SCREW, for fastening Resistor to Plate.....	8098-1225
163833	6	SPACER.....	8350-513
139691	7	BUSHING, for use in wire inlet hole in office coding and line and field coding and line units.....	8095-644
	8	MACHINE SCREW, NO.10-30 x 1/2" Fil.Hd.S.(N.P.)	
169062	9	FILLER BLOCK, WOOD U - 1-15/16", V - 4-1/2", W - 7/8".....	12443-180
169063	9a	FILLER BLOCK, WOOD U - 1-5/8", V - 4-1/2", W - 1/2".....	12443-181
168918	9b	FILLER BLOCK, WOOD U - 1-15/16", V - 4-1/2", W - 1-1/4".....	12443-183
	10	MACHINE SCREW, NO.6-40 x 5/16" Rd.Hd.Br.(N.P.)	
168917	11	RESISTOR (5 ohms).....	9065-218
54002	12	LEAD, 9" LONG.....	B-9998-6
163851	13	TERMINAL BRACKET COMPLETE.....	10914-227
168916	14	CONDENSER.....	B-12549-15
168460	15	TERMINAL RACK COMPLETE, with L.H. Clip, for Office Code, Field Code and Field Storage Units.....	C-9232-20
170671	15a	TERMINAL RACK COMPLETE, with R.H. Clip, for Office Code, Field Code and Field Storage Units.....	C-9232-20
170672	15b	TERMINAL RACK COMPLETE, with L.H. and R.H. Clips, for Office Code, Field Code and Field Storage Units.....	C-9232-20
168830	16	TERMINAL RACK COMPLETE, with R.H. Clip, for Office Line Unit..	C-9232-31
170673	16a	TERMINAL RACK COMPLETE, with L.H. Clip, for Office Line Unit..	C-9232-31
168711	17	TERMINAL RACK COMPLETE, with L.H. Clip, for Field Line Unit...	C-9232-31
168706	18	TERMINAL BOARD ONLY, for Office Code and Field Code Units.....	C-9232-25
168428	19	TERMINAL BOARD ONLY, for Field Storage Unit.....	C-9232-21
168834	20	TERMINAL BOARD ONLY, for Office Line Unit.....	C-9232-25
168707	21	TERMINAL BOARD ONLY, for Field Line Unit.....	C-9232-25
161398	22	TERMINAL BOARD ONLY.....	C-9232-10
161457	23	TERMINAL RACK.....	C-9232-11
161595	24	TERMINAL POST.....	8094-2252
161594	25	TERMINAL SCREW.....	8098-920
161456	26	SEALING CUP.....	11893-313
54921	27	RIVET.....	10301-1
13928	28	WASHER.....	7828-46

## UNION SWITCH &amp; SIGNAL CO.

PIECE	REF.	DESCRIPTION	DWG. REF.
162092	29	MARKING STRIP (orders should specify lettering required, designate position of strip on terminal board).....	8988-83
	30	MACHINE SCREW, NO.4-48 x 3/16" Rd.Hd.Br.(N.P.)	
161584	31	INS.SUPPORT.....	9999-714
161585	32	INS.SUPPORT.....	9999-713
161583	33	INS.SUPPORT.....	8750-2374
161590	34	CONNECTOR.....	8064-685
136048	35	EYELET.....	12579-2
143762	36	EYELET.....	12579-2
162093	37	CLIP.....	12538-58
130994	38	EYELET.....	12579-1
	39	MACHINE SCREW, NO.4-48 x 1/2" Rd.Hd.Br.(N.P.) with Nut Ref.39a	
40916	39a	NUT for Ref.39.....	8109-272
171257	40	INSULATION S - 3-3/4", T - 5-3/4" (1/32" Thick).....	8750-2473
171258	40a	INSULATION S - 5-5/8", T - 7-5/8" (1/32" Thick).....	8750-2473
171277	40b	INSULATION S - 1-7/8", T - 3-7/8" (1/32" Thick).....	8750-2473
171259	41	INSULATION "U" - 7-1/2", "V" - 9-1/2" (1/32" Thick).....	8750-2474
182496	41a	INSULATION "U" - 5-5/8", "V" - 7-5/8" (1/32" Thick).....	8750-2474
	42	MACHINE SCREW, NO.3-56 x 5/8" Fil.Hd.S.(N.P.)	
171276	43	BUSHING.....	B-10266-1
174235	44	INSULATION (1/8" Thick).....	8750-2503
152721	45	COIL CONNECTOR.....	8064-663
168743	46	RESISTOR (400-ohms) for field storage unit.....	9065-217
171576	46a	RESISTOR (94-ohms) for field coding unit.....	9065-217
163850	47	BRACKET ONLY.....	10914-227
29714	48	NUT.....	8109-207
161591	49	CONNECTOR.....	8064-686
168426	50	MARKING STRIP (Marked 1, 2, B, XL, YL, ZL).....	8988-92
168414	51	MARKING STRIP (Marked 1, 2, 3, 4, 5, 6).....	8988-89
168415	52	MARKING STRIP (Marked 7, 8, 9, 10, 11, 12).....	8988-89
168424	53	MARKING STRIP (Marked B, 56, C, X, Y, Z).....	8988-91
168417	54	MARKING STRIP (Marked 19, 20, 21, 22, 23, 24).....	8988-89
168418	55	MARKING STRIP (Marked 25, 26, 27, 28, 29, 30).....	8988-90
168419	56	MARKING STRIP (Marked 31, 32, 33, 34, 35, 36).....	8988-90



# UNION SWITCH & SIGNAL CO.

PIECE	REF.	DESCRIPTION	DWG. REF.
168420	57	MARKING STRIP (Marked 37, 38, 39, 40, 41, 42).....	8988-90
168421	58	MARKING STRIP (Marked 43, 44, 45, 46, 47, 48).....	8988-90
168422	59	MARKING STRIP (Marked 49, 50, 51, 52, 53, 54).....	8988-91
168416	60	MARKING STRIP (Marked 13, 14, 15, 16, 17, 18).....	8988-89
168425	61	Marking Strip (Marked X, Y, Z, B, Blank, C).....	8988-91
168423	62	MARKING STRIP (Marked 55, 56, 57, 58, 59, 60).....	8988-91
168427	63	MARKING STRIP (Marked OXL, OYL, BLANK, XR, YR, ZR).....	8988-92
	64	COMPENSATING RESISTOR TYPE SU21A-44 (1200-Ohms) (Not shown)	
	64a	COMPENSATING RESISTOR TYPE SU21A-45 (600-ohm) (Not shown)	

# UNION SWITCH & SIGNAL CO.

PLATE T-66

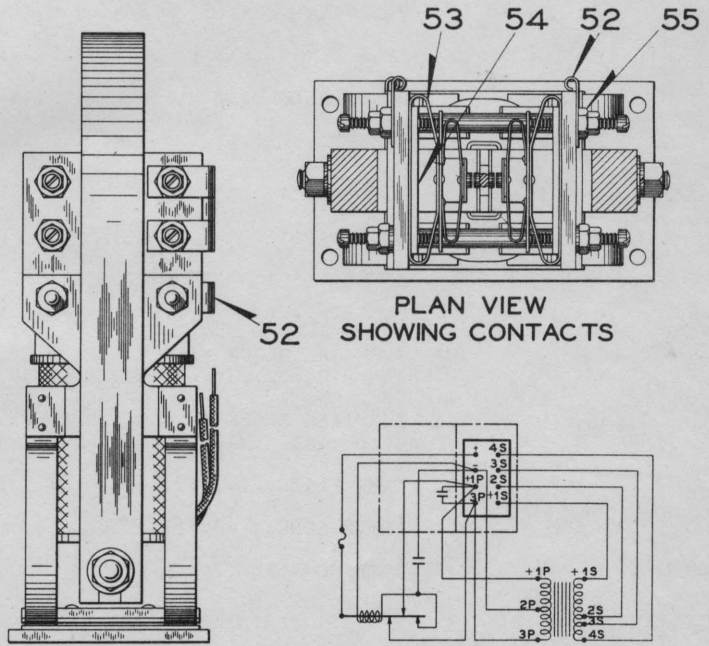
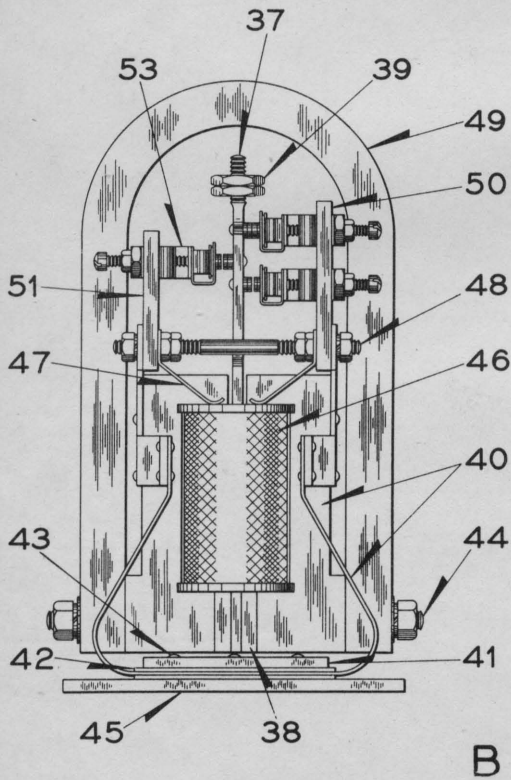
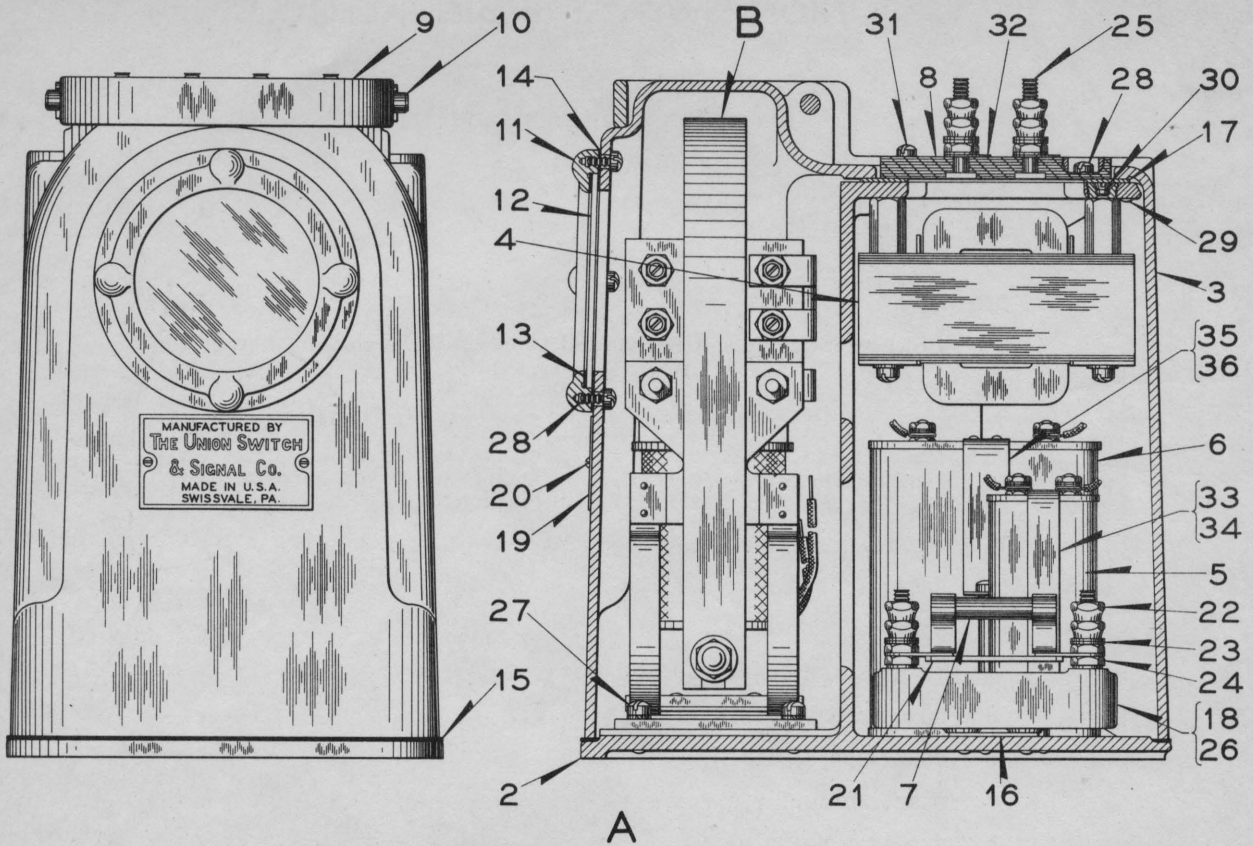

## TUNED ALTERNATOR



# UNION SWITCH & SIGNAL Co.

## CENTRALIZED TRAFFIC CONTROL SYSTEM

### DETAIL PARTS

#### TUNED ALTERNATOR

When ordering for replacement state Installation

**Order by Plate, Piece, Reference and Abbreviated Description Given in Heavy Face Type Only**

PIECE	REF.	DESCRIPTION	DWG. REF.
208753	A	TUNED ALTERNATOR COMPLETE, with Transformer and Condensers (60-Cycles, 15-Volts D.C., 110-Volts A.C.).....	C-9358-2
208752	B	TUNED ALTERNATOR (60-Cycles, 15-Volts D.C. Input).....	C-9358-3
174306	2	BASE.....	C-9387-1
165720	3	COVER.....	C-9387-2
208750	4	TRANSFORMER COMPLETE, 110 Volts, 60 Cycles.....	C-8605-5
183018	5	CONDENSER COMPLETE, 2 Mf.....	B-12549-21
182459	6	CONDENSER COMPLETE, 7 Mf.....	B-12549-22
	7	FUSE, 10-Amp. 250-Volts	
181019	8	TERMINAL BOARD.....	9968-1093
181020	9	HANDLE.....	8311-103
181026	10	PIN with two 1/8" x 3/4" S.Cotters (Tin Pl.).....	B-10205-1
174307	11	LENS RING.....	7632-242
177013	12	GLASS SHIELD.....	8163-222
177011	13	GASKET.....	8078-1167
177012	14	GASKET.....	8078-1531
181162	15	GASKET.....	8078-1449
121356	16	GASKET.....	8078-1372
181022	17	GASKET.....	8078-1552
	18	TERMINAL BLOCK with Nuts and Washers (Inc.1-18a, 4-22, 4-23 and 2-24).....	9065-
132198	18a	TERMINAL BLOCK with one Nut Ref.24 and one Washer Ref.23 on each post.....	9065-155
51264	19	NAME PLATE.....	8225-141
	20	DRIVE SCREW, NO.4 x 3/16" Hardened (Cad.Pl.)	
124812	21	CLIP COMPLETE.....	8064-560
29101	22	NUT.....	8109-193
29102	23	WASHER.....	7828-139
29103	24	NUT.....	8109-194
	25	TERMINAL POST with Nuts and Washers (Inc.1-25a, 2-22, 3-23 and 1-24).....	12451-

# UNION SWITCH & SIGNAL CO.

PIECE	REF.	DESCRIPTION	DWG. REF.
40066	25a	TERMINAL POST ONLY, for Ref.25.....	8094-797
	26	MACHINE SCREW, NO.14-24 x 1" Fil.Hd.S. (Tin.Pl.) for attaching Terminal Block Ref.18 to Case.	
	27	MACHINE SCREW, NO.14-24 x 5/8" Fil.Hd.S. (Tin Pl.) with 1/4" Pl.S.Lock Washer (9/64" x 5/64") (Tin Pl.)	
	28	MACHINE SCREW, NO.10-30 x 3/8" Fil.Hd.S. (Tin Pl.)	
	29	MACHINE SCREW, NO.14-24 x 3/4" Flat Hd.S. (Tin Pl.)	
	30	MACHINE SCREW, NO.14-24 x 5/8" Flat Hd.S. (Tin Pl.)	
	31	MACHINE SCREW, NO.10-30 x 3/4" Fil.Hd.S. (Tin Pl.)	
142777	32	TAG (Orders should specify marking desired).....	8988-75
187154	33	CLAMP.....	10914-312
	34	MACHINE SCREW, NO.8-36 x 1/2" Fil.Hd.S. (Tin Pl.)	
182464	35	CLAMP COMPLETE.....	11893-678
	36	MACHINE SCREW, NO.10-30 x 2-5/8" Fil.Hd.S. (Tin Pl.)	
181248	37	ARMATURE with Contact Tips.....	8157-403
162615	38	SPACER.....	7828-367
170869	39	NUT.....	8109-458
181692	40	YOKE ASSEMBLY COMPLETE (Inc.1-40a, 1-40b, 2-40c, 4-40d and 4-40e).....	8250-97
181231	40a	POLE PIECE for Ref.40.....	8250-96
181232	40b	BRACKET.....	10914-497
181241	40c	SPRING.....	8735-774
	40d	RIVET, 1/8" x 3/4" Rd.Hd.Iron (Cad.Pl.) for attaching Bracket Ref.40b to Pole Piece Ref.40a	
	40e	RIVET, 1/8" x 5/16" Rd.Hd.Iron (Cad.Pl.) for attaching Spring Ref.40c to Bracket Ref.40b	
162631	41	SPRING CLAMP.....	12538-88
162644	42	INSULATION.....	8750-2464
	43	MACHINE SCREW, NO.14-24 x 9/16" Flat Hd.S. (Tin Pl.)	
	44	STUD with Nuts and Washers (Inc.1-44a, 2-44b, two 3/8" Pl.S. Lock Washers (11/64" x 7/64")(Cad.Pl.) and two 3/8"-24 Hex. Nuts (Cad.Pl.).....	12471-
182159	44a	STUD ONLY, for Ref.44.....	8114-832
62222	44b	WASHER.....	7826-180
181021	45	SUPPORTING PLATE.....	9999-1006
208751	46	COIL COMPLETE.....	8133-425
181233	47	SPRING.....	8735-773
	48	SCREW with Nuts and Washers (Inc.1-48a, 6-48b and two 1/4" Pl. S.Lock Washers (1/16" x 1/16") (Tin Pl.).....	12471-
77514	48a	SCREW ONLY, for Ref.48.....	8098-1402
127260	48b	NUT.....	8109-194
162618	49	MAGNET.....	12586-8



# UNION SWITCH & SIGNAL CO.

PIECE	REF.	DESCRIPTION	DWG. REF.
181565	50	TERMINAL BOARD COMPLETE (Inc.1-50a, 2-52, 2-53, 2-54 and 4-55)	9968-1098
181240	50a	TERMINAL BOARD ONLY, for Ref.50.....	9968-1097
181566	51	TERMINAL BOARD COMPLETE (Inc.1-51a, 1-52, 1-53, 1-54 and 2-55)	9968-1099
181239	51a	TERMINAL BOARD ONLY, for Ref.51.....	9968-1096
171059	52	TERMINAL CLIP.....	8244-146
181238	53	CONTACT SPRING COMPLETE.....	8385-2340
162629	54	CONTACT CLAMP.....	12538-89
	55	TERMINAL POST with Nut, Washer and Screw (Inc.1-55a, 1-55b, 1-55c and 1-55d).....	12451-
162627	55a	TERMINAL POST ONLY, for Ref.55.....	8094-2287
40052	55b	WASHER.....	7828-174
181237	55c	SCREW.....	8098-808
29713	55d	NUT.....	8109-206

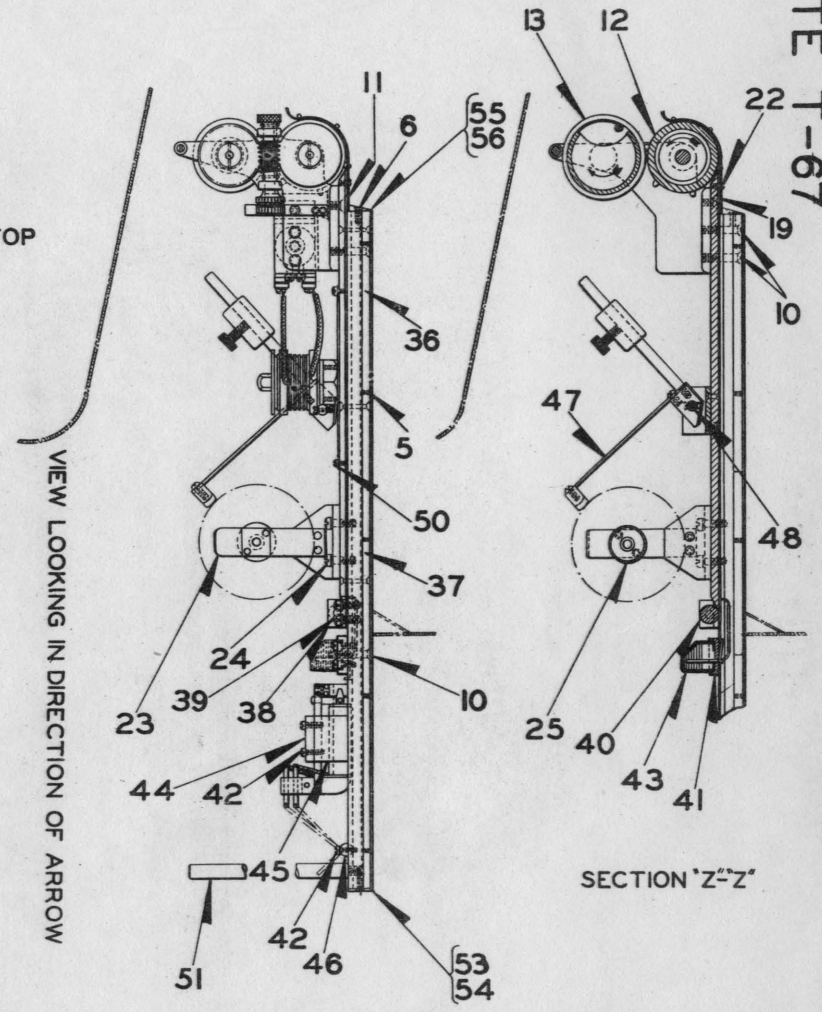
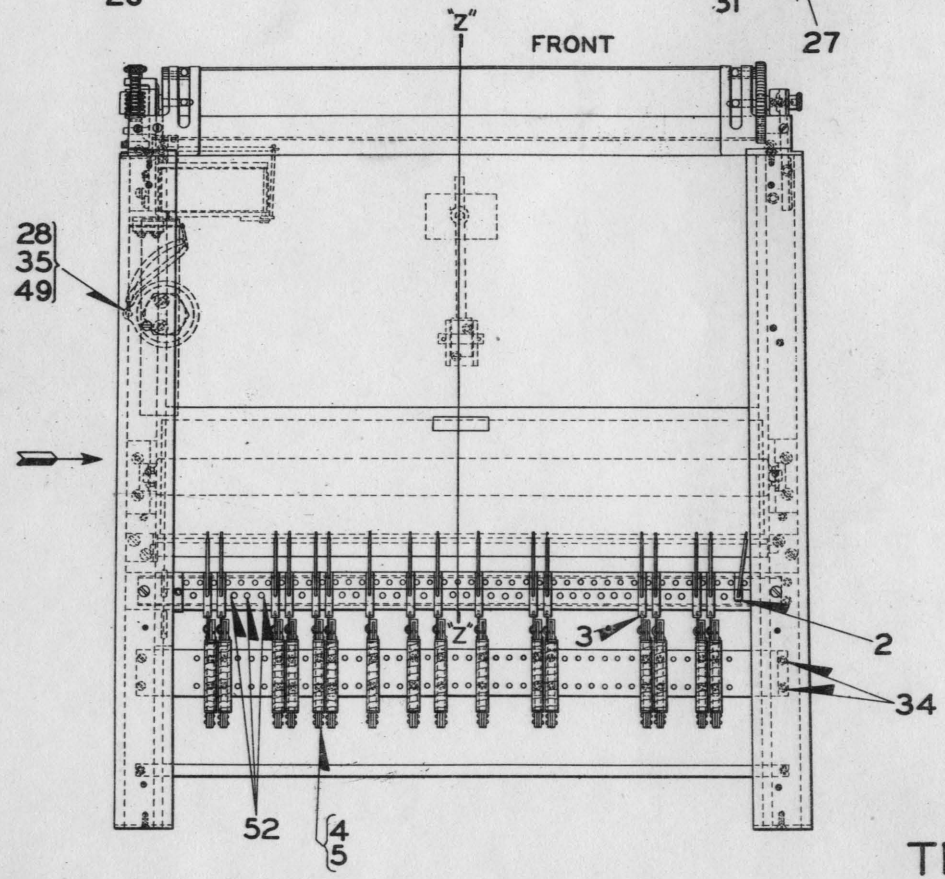
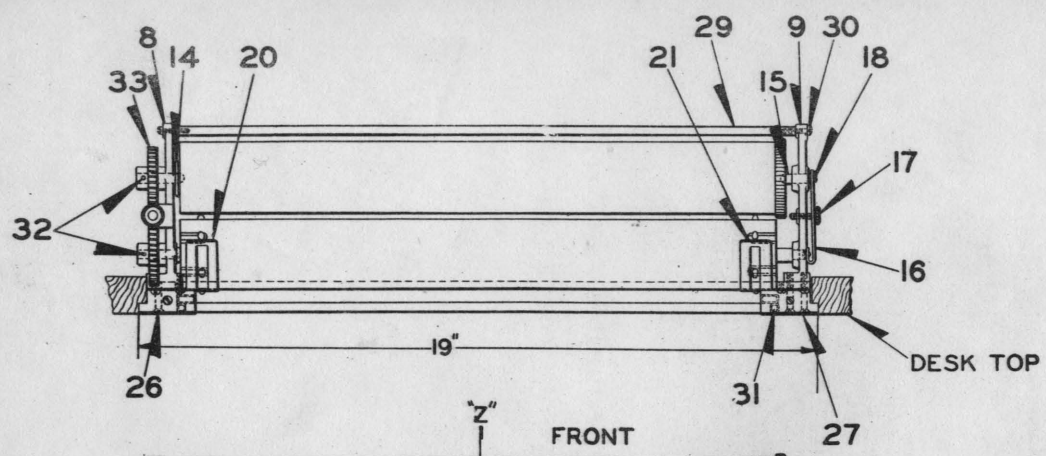

SECTION 'Z-Z'

TRAIN GRAPH



# UNION SWITCH & SIGNAL CO.

## CENTRALIZED TRAFFIC CONTROL SYSTEM

### DETAIL PARTS

For other details see Plates T-69 and T-71.

### TRAIN GRAPH

When ordering for replacement state installation.

Order by Plate, Piece, Reference and Abbreviated Description Given in Heavy Face Type

Piece	Ref.	Description	Drawing Reference
		<b>TRAIN GRAPH COMPLETE, with Driving Mechanism Ref.A, Plate T-69.</b>	
	2	PILOT PEN (For details refer to Plate T-71)	
	3	PEN COMPLETE (For details refer to Plate T-71)	
	4	PEN MAGNET COMPLETE (For details refer to Plate T-71)	
	5	MACHINE SCREW NO. 6-40 x 3/8" Csk.Hd.Br. (N.P.)	
	6	MACHINE SCREW NO. 4-48 x 3/8" Csk. Hd.Br. (N.P.)	
168147	7	BASE PLATE COMPLETE.....	C-9348-6
	8	DRIVING MECHANISM COMPLETE, (For details refer to Plate T-69)	
164081	9	END SUPPORT.....	C-9348-2
	10	MACHINE SCREW NO.10-30 x 1" Flat Hd.Br.(N.P.)	
	11	MACHINE SCREW NO.10-30 x 3/8" Csk.Hd.Br.(N.P.)	
170193	12	DRIVE ROLL COMPLETE.....	C-9348-8
170206	13	TAKE UP ROLL COMPLETE.....	C-9348-9
168092	14	PIVOT SHAFT COMPLETE.....	12501-59
168090	14a	WASHER (Brown kid leather for clutch surface).....	8078-1483
168093	15	PIVOT SHAFT COMPLETE.....	12501-70
168078	16	RETAINING SPRING COMPLETE.....	8735-721
168095	17	SCREW.....	8098-675
168094	18	SCREW.....	8098-674
168055	19	SHIM.....	11893-546
168096	20	R.H. PAPER CLIP.....	8735-725
168097	21	L.H. PAPER CLIP.....	8735-725
	22	MACHINE SCREW NO. 6-40 x 1/4" Rd.Hd.Br. (N.P.)	
168126	23	BRACKET COMPLETE.....	C-9348-2

## UNION SWITCH &amp; SIGNAL CO.

PIECE	REF.	DESCRIPTION	DWG. REF.
	24	MACHINE SCREW NO.10-30 x 5/8" Fil.Hd.Br.(N.P.) with 3/16" Plain S. Lock Washer (3/32" x 1/32") Cad.Pl.	
187784	25	PAPER ROLL COMPLETE.....	C-9348-24
168130	26	R.H. CLAMPING STRIP.....	C-9348-3
168129	27	L.H. CLAMPING STRIP.....	C-9348-3
181530	28	SUPPORT PLATE, for Rectifier.....	12558-111
175245	29	ROD.....	8114-792
	30	MACHINE SCREW NO.6-40 x 5/8" Fil.Hd.Br.(N.P.) for Ref.29	
170217	31	SPACER COMPLETE.....	C-9348-10
70159	32	PIN.....	8097-999
	33	GEAR TRAIN	
	34	MACHINE SCREW NO.6-40 x 1-1/2" Fil.Hd.Br.(N.P.)	
181307	35	RECTIFIER COMPLETE for Ref. A .....	12558-23
170219	36	GLASS TOP (FRONT SECTION).....	C-9348-11
170218	37	GLASS TOP (REAR SECTION).....	C-9348-11
168114	38	BRACKET.....	10914-280
	39	MACHINE SCREW NO.10-30 x 1/2" Fil.Hd.Br.(N.P.) with 3/16" Plain Lock Washer (3/32" x 1/32") Cad.Pl.	
170211	40	ROLLER.....	12501-67
168143	41	PEN HOLDER COMPLETE.....	C-9348-4
	42	MACHINE SCREW NO.6-40 x 1/2" Fil.Hd.Br.(N.P.)	
168141	43	INKWELL COMPLETE.....	C-9348-4
168144	44	MAGNET SUPPORT.....	C-9348-4
168054	45	SPACER.....	9999-792
170212	46	CABLE SUPPORT.....	12501-68
168104	47	BRAKE COMPLETE.....	C-9348-3
74925	48	PIN with two 1/16" x 3/8" S.Cotter (N.P.).....	B-10203-1
	49	MACHINE SCREW NO.10-30 x 3/8" Fil.Hd.Br.(Cad.Pl.) for Ref.35	
	50	MACHINE SCREW NO.4-48 x 5/16" Fil.Hd.Br.(N.P.)	
168117	51	LEG.....	8114-765
168133	52	BUTTON.....	8097-1038
168086	53	R.H. STOP.....	11893-552
168087	54	L.H. STOP.....	11893-552
168088	55	R.H. STOP.....	12538-96
168089	56	L.H. STOP.....	12538-96

For all other Graph Details refer to Plates T-69 and T-71.

5-32 7-35



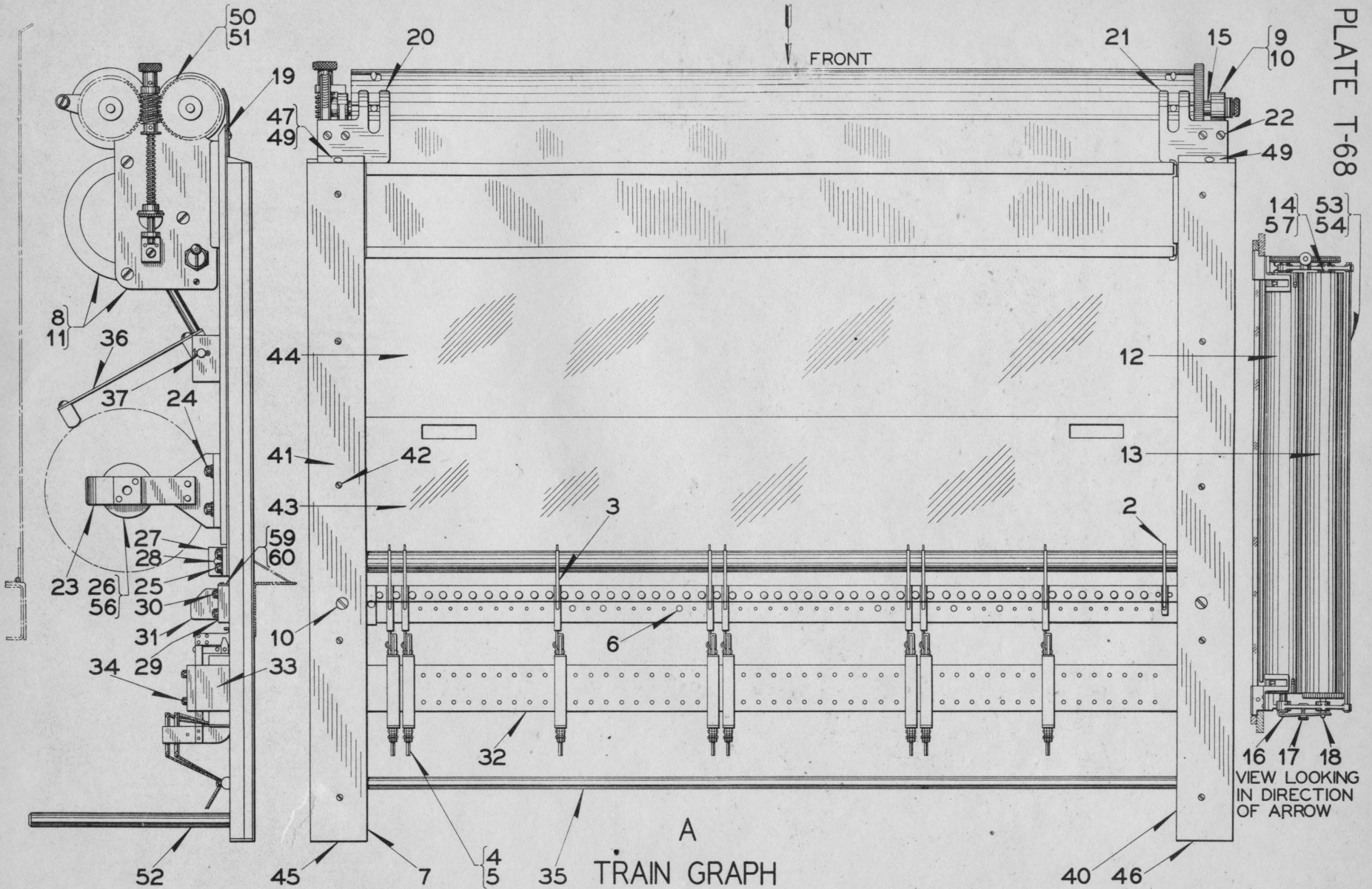

# UNION SWITCH & SIGNAL CO.

## CENTRALIZED TRAFFIC CONTROL SYSTEM

### DETAIL PARTS

For other details see Plates T-69A and T-71

### TRAIN GRAPH

When ordering for replacement state installation.

**Order by Plate, Piece, Reference and Abbreviated Description Given in Heavy Face Type Only**

PIECE	REF.	DESCRIPTION	DWG. REF.
	A	TRAIN GRAPH COMPLETE, with Driving Mechanism Ref.A,Plate T-69A	C-9365-
	2	PILOT PEN (For details refer to Plate T-71)	
	3	PEN COMPLETE (For details refer to Plate T-71)	
	4	PEN MAGNET COMPLETE (For details refer to Plate T-71)	
	5	MACHINE SCREW, NO.6-40 x 1/2" Fil.Hd.Br. (N.P.)	
168133	6	BUTTON (Used in Blank Spaces).....	8097-1038
102464	7	BASE PLATE COMPLETE.....	C-9348-31
	8	DRIVING MECHANISM COMPLETE (For details refer to Plate T-69A)	
164081	9	END SUPPORT.....	C-9348-2
	10	MACHINE SCREW, NO.10-30 x 1" Flat Hd.Br. (N.P.)	
	11	MACHINE SCREW, NO.10-30 x 3/8" Flat Hd.Br. (N.P.) For attaching Driving Mechanism to Base Plate	
208819	12	DRIVE ROLL COMPLETE.....	C-9348-8
208813	13	TAKE UP ROLL COMPLETE.....	C-9348-9
183178	14	PIVOT SHAFT.....	12501-59
168093	15	PIVOT SHAFT.....	12501-70
168078	16	RETAINING SPRING COMPLETE.....	8735-721
168095	17	SCREW.....	8098-675
168094	18	SCREW.....	8098-674
168055	19	SHIM.....	11893-546
104173	20	PAPER CLIP, R.H.....	8735-885
104174	21	PAPER CLIP, L.H.....	8735-885
	22	MACHINE SCREW, NO.6-40 x 1/4" Rd.Hd.S. (N.P.)	
208329	23	BRACKET COMPLETE.....	C-9348-2
	24	MACHINE SCREW, NO.10-30 x 5/8" Fil.Hd.Br. (N.P.) with No.10 Pl.S.Lock Washer (1/16" x 3/64") (Tin Pl.)	
	25	MACHINE SCREW, NO.10-30 x 1/2" Fil.Hd.Br. (N.P.) with No.10 Pl.S.Lock Washer (1/16" x 3/64") (Tin Pl.)	
208827	26	PAPER ROLL SUPPORT SHAFT COMPLETE with Nut Ref.56.....	C-9348-24
168114	27	BRACKET.....	10914-280



## UNION SWITCH &amp; SIGNAL CO.

PIECE	REF.	DESCRIPTION	DWG. REF.
208823	28	ROLLER.....	12501-67
102437	29	PEN HOLDER COMPLETE.....	C-9348-29
	30	MACHINE SCREW, NO.6-40 x 1/2" Fil.Hd.Br. (N.P.)	
208748	31	INKWELL COMPLETE.....	C-9348-4
102443	32	MAGNET SUPPORT.....	C-9348-29
168054	33	SPACER.....	9999-792
	34	MACHINE SCREW, NO.6-40 x 1-1/2" Fil.Hd.Br. (N.P.)	
208824	35	CABLE SUPPORT.....	12501-68
168104	36	BRAKE COMPLETE.....	C-9348-3
74925	37	PIN with two 1/16" x 3/8" S.Cotters (Tin Pl.).....	B-10203-1
209512	38	SPACER COMPLETE (Used under R.H.Side of Base Plate)(Not shown)	C-9348-10
185454	39	SPACER COMPLETE (Used under L.H.Side of Base Plate)(Not shown)	C-9348-10
168129	40	CLAMPING STRIP, L.H.....	C-9348-3
168130	41	CLAMPING STRIP, R.H.....	C-9348-3
	42	MACHINE SCREW, NO.6-40 x 3/8" Flat Hd.Br. (N.P.)	
208869	43	GLASS TOP.....	C-9348-11
208870	44	GLASS TOP.....	C-9348-11
168086	45	STOP, R.H.....	11893-552
168087	46	STOP, L.H.....	11893-552
168088	47	STOP, R.H.....	12538-96
168089	48	STOP, L.H.....	12538-96
	49	MACHINE SCREW, NO.4-48 x 3/8" Flat Hd.Br. (N.P.)	
102573	50	WORM GEAR.....	8424-292
70159	51	PIN.....	8097-999
208286	52	LEG.....	8114-765
208828	53	ROD.....	8114-792
	54	MACHINE SCREW, NO.6-40 x 5/8" Fil.Hd.Br. (N.P.)	
57497	55	PIN (For attaching Driving Mechanism to Base Plate)(Not shown)	8097-872
187546	56	NUT.....	8109-477
168090	57	WASHER.....	8078-1483
	58	MACHINE SCREW, NO.2-64 x 1/8" Flat Hd.Br. (N.P.) (Not shown)	
103464	59	PAPER CLIP.....	C-9348-35
	60	MACHINE SCREW, NO.2-64 x 3/16" Rd.Hd.Br. (N.P.)	

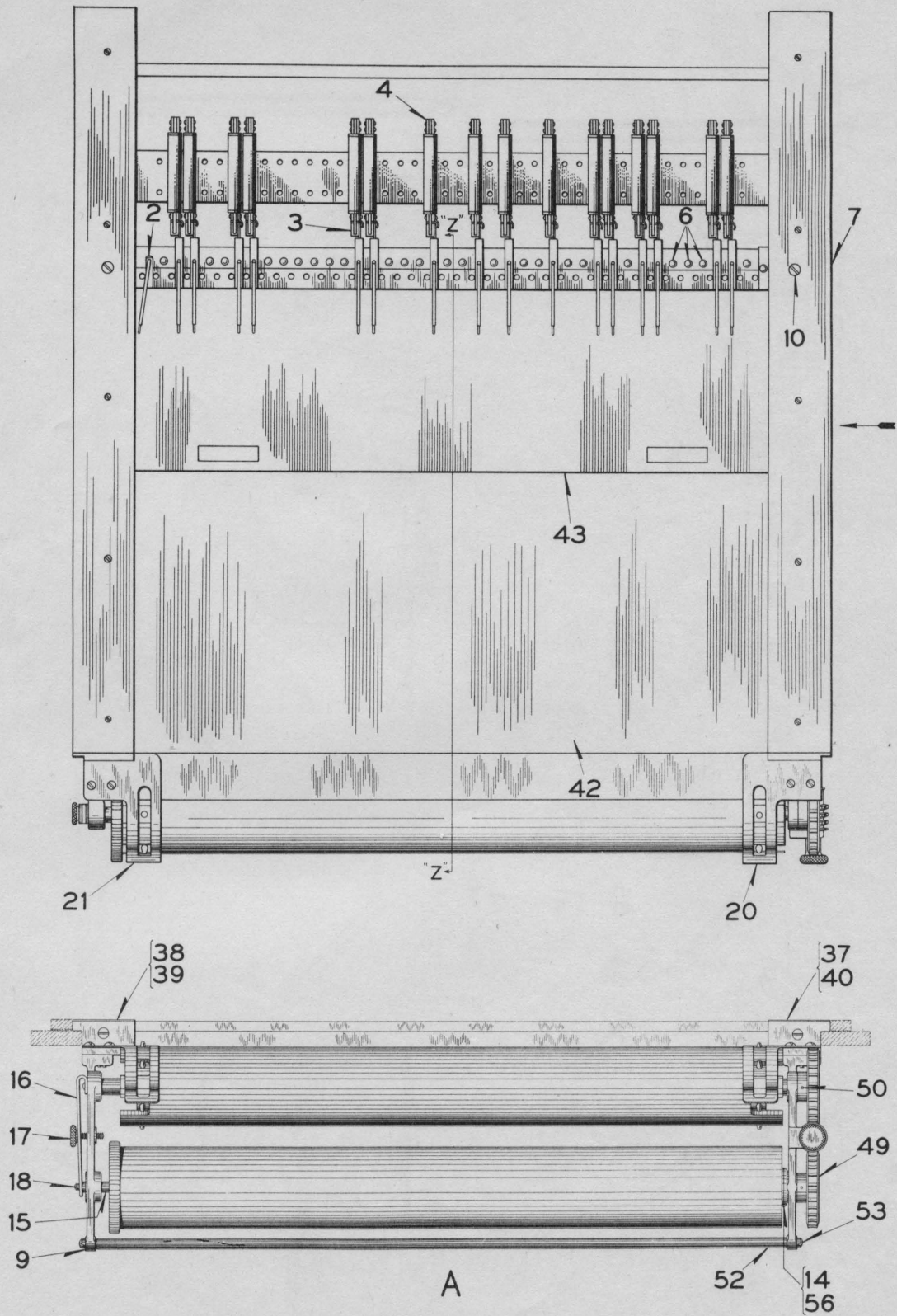

TRAIN GRAPH



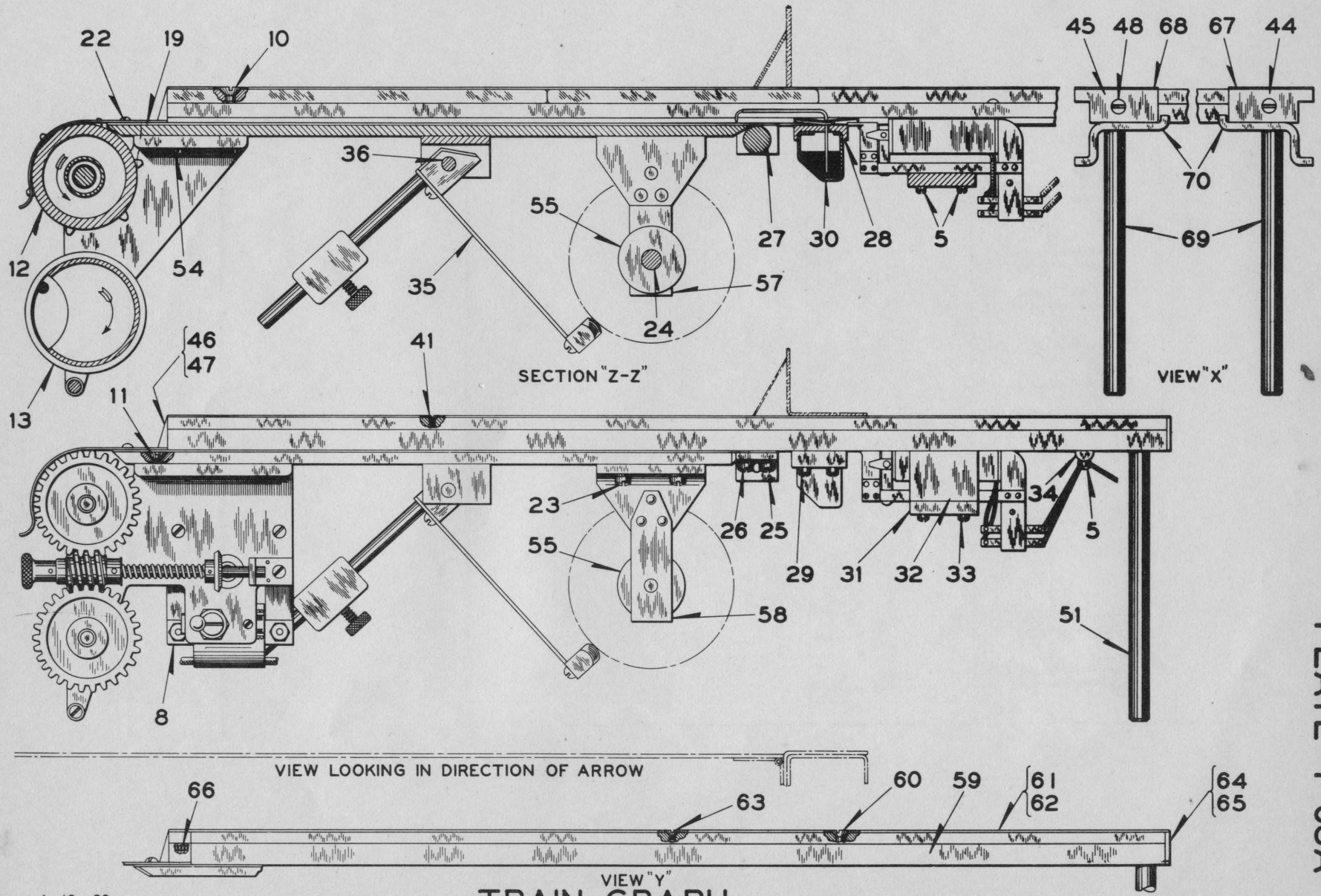

PLATE T-68A

TRAIN GRAPH

# UNION SWITCH & SIGNAL CO.

## CENTRALIZED TRAFFIC CONTROL SYSTEM

### DETAIL PARTS

For other details see Plates T-69-B and T-71

### TRAIN GRAPH

When ordering for replacement state installation

**Order by Plate, Piece, Reference and Abbreviated Description Given in Heavy Face Type Only**

PIECE	REF.	DESCRIPTION	DWG. REF.
	A	TRAIN GRAPH COMPLETE as shown with Driving Mechanism Ref.A, Plate T-69-B	
	Aa	TRAIN GRAPH COMPLETE per View "Y" with Driving Mechanism Ref.A, Plate T-69-B	
	Ab	TRAIN GRAPH COMPLETE per View "X" with Driving Mechanism Ref.A, Plate T-69-B	
	2	PILOT PEN (For details refer to Plate T-71)	
	3	PEN COMPLETE (For details refer to Plate T-71)	
	4	PEN MAGNET COMPLETE (For details refer to Plate T-71)	
	5	MACHINE SCREW, NO.6-40 x 1/2" Fil.Hd.Br. (N.P.)	
168133	6	BUTTON (Used in Blank Spaces).....	8097-1038
168147	7	BASE PLATE COMPLETE.....	C-9348-6
	8	DRIVING MECHANISM COMPLETE (For details refer to Plate T-69-B)	
182176	9	END SUPPORT.....	C-9348-22
	10	MACHINE SCREW, NO.10-30 x 1" Flat Hd.Br. (N.P.)	
	11	MACHINE SCREW, NO.10-30 x 3/8" Flat Hd.Br. (N.P.)	
105997	12	DRIVE ROLL COMPLETE.....	C-9348-37
170206	13	TAKE UP ROLL COMPLETE.....	C-9348-9
183178	14	PIVOT SHAFT.....	12501-59
168093	15	PIVOT SHAFT.....	12501-70
183176	16	RETAINING SPRING COMPLETE.....	8735-782
168095	17	SCREW.....	8098-675
168094	18	SCREW.....	8098-674
168055	19	SHIM.....	11893-546
168096	20	R.H. PAPER CLIP.....	8735-725
168097	21	L.H. PAPER CLIP.....	8735-725
	22	MACHINE SCREW, NO.6-40 x 1/4" Rd.Hd.S. (N.P.)	
	23	MACHINE SCREW, NO.10-30 x 5/8" Fil.Hd.Br. (N.P.) with No.10 Pl.S.Lock Washer (1/16" x 3/64") (Tin Pl.)	
105684	24	PAPER ROLL SUPPORT SHAFT COMPLETE.....	C-9348-24
168114	25	BRACKET.....	10914-280



# UNION SWITCH & SIGNAL CO.

PIECE	REF.	DESCRIPTION	DWG. REF.
	26	MACHINE SCREW, NO.10-30 x 1/2" Fil.Hd.Br. (N.P.) with No.10 Pl.S.Lock Washer (1/16" x 3/64") (Tin Pl.)	
170211	27	ROLLER.....	12501-67
168143	28	PEN HOLDER COMPLETE.....	C-9348-4
	29	MACHINE SCREW, NO.6-40 x 1/2" Fil.Hd.Br. (N.P.)	
168141	30	INKWELL COMPLETE.....	C-9348-4
168144	31	MAGNET SUPPORT.....	C-9348-4
168054	32	SPACER.....	9999-792
	33	MACHINE SCREW, NO.6-40 x 1-1/2" Fil.Hd.Br. (N.P.)	
170212	34	CABLE SUPPORT.....	12501-68
168104	35	BRAKE COMPLETE.....	C-9348-3
74925	36	PIN with two 1/16" x 3/8" S.Cotters (Tin Pl.).....	B-10203-1
209512	37	SPACER COMPLETE.....	C-9348-10
185454	38	SPACER COMPLETE.....	C-9348-10
168129	39	L.H. CLAMPING STRIP.....	C-9348-3
168130	40	R.H. CLAMPING STRIP.....	C-9348-3
	41	MACHINE SCREW, NO.6-40 x 3/8" Flat Hd.Br. (N.P.)	
170219	42	GLASS TOP.....	C-9348-11
170218	43	GLASS TOP.....	C-9348-11
168086	44	R.H. STOP.....	11893-552
168087	45	L.H. STOP.....	11893-552
168088	46	R.H. STOP.....	12538-96
168089	47	L.H. STOP.....	12538-96
	48	MACHINE SCREW, NO.4-48 x 3/8" Flat Hd.Br. (N.P.)	
183183	49	GEAR COMPLETE.....	8424-274
70159	50	PIN.....	8097-999
183185	51	LEG.....	8114-765
183177	52	ROD.....	8114-792
	53	MACHINE SCREW, NO.6-40 x 5/8" Fil.Hd.Br. (N.P.)	
57497	54	PIN.....	8097-872
105712	55	NUT.....	8350-780
168090	56	WASHER.....	8078-1483
105728	57	L.H. BRACKET COMPLETE.....	C-9348-16
105729	58	R.H. BRACKET COMPLETE.....	C-9348-16
198337	59	BASE PLATE COMPLETE for Ref.Aa.....	C-9348-27
	60	MACHINE SCREW, NO.10-30 x 1" Flat Hd.Br. (Head painted Olive Green) for Ref.Aa	
198335	61	L.H. CLAMPING STRIP for Ref.Aa.....	C-9348-27
198336	62	R.H. CLAMPING STRIP for Ref.Aa.....	C-9348-27

# UNION SWITCH & SIGNAL CO.

PIECE	REF.	DESCRIPTION	DWG. REF.
	63	MACHINE SCREW, NO.6-40 x 3/8" Flat Hd.Br. (Head painted Olive Green) for Ref.Aa	
198340	64	R.H. STOP COMPLETE for Ref.Aa.....	12538-161
198341	65	L.H. STOP COMPLETE for Ref.Aa.....	12538-161
	66	MACHINE SCREW NO.4-48 x 3/4" Flat Hd.Br. (N.P.) for Ref.Aa	
210586	67	L.H. CLAMPING STRIP for Ref.Ab.....	C-9348-3
210587	68	R.H. CLAMPING STRIP for Ref.Ab.....	C-9348-3
210597	69	LEG for Ref.Ab.....	8114-765
104023	70	GUIDE BRACKET for Ref.Ab.....	10914-928
4-10-39			



PLATE T-69

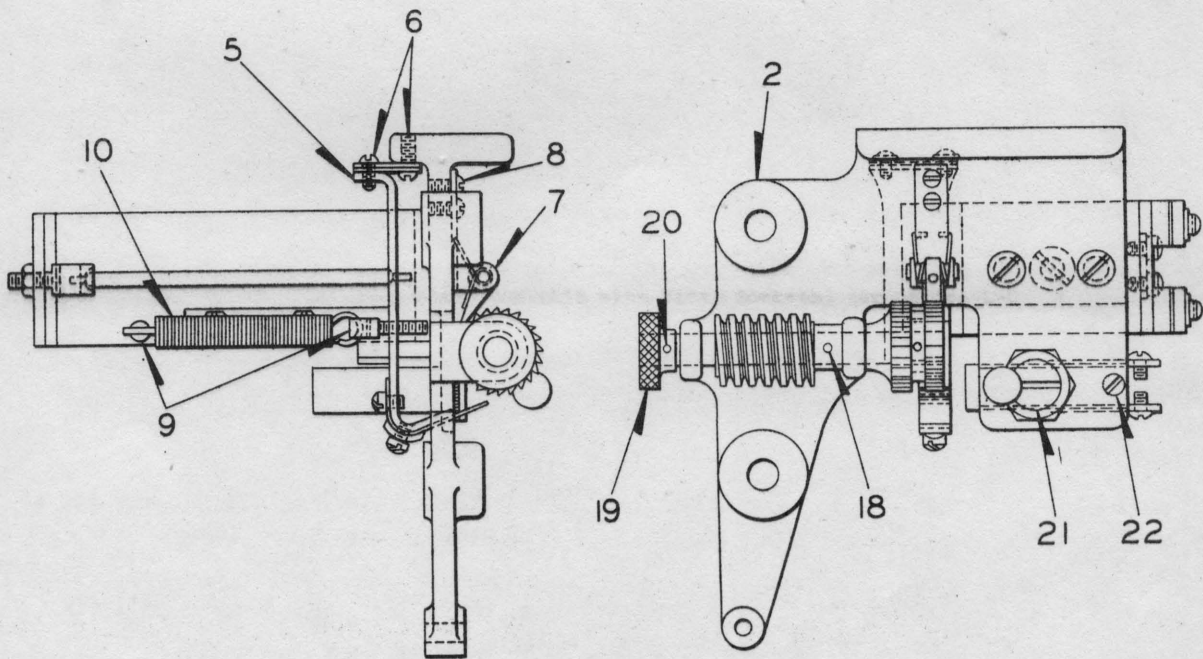
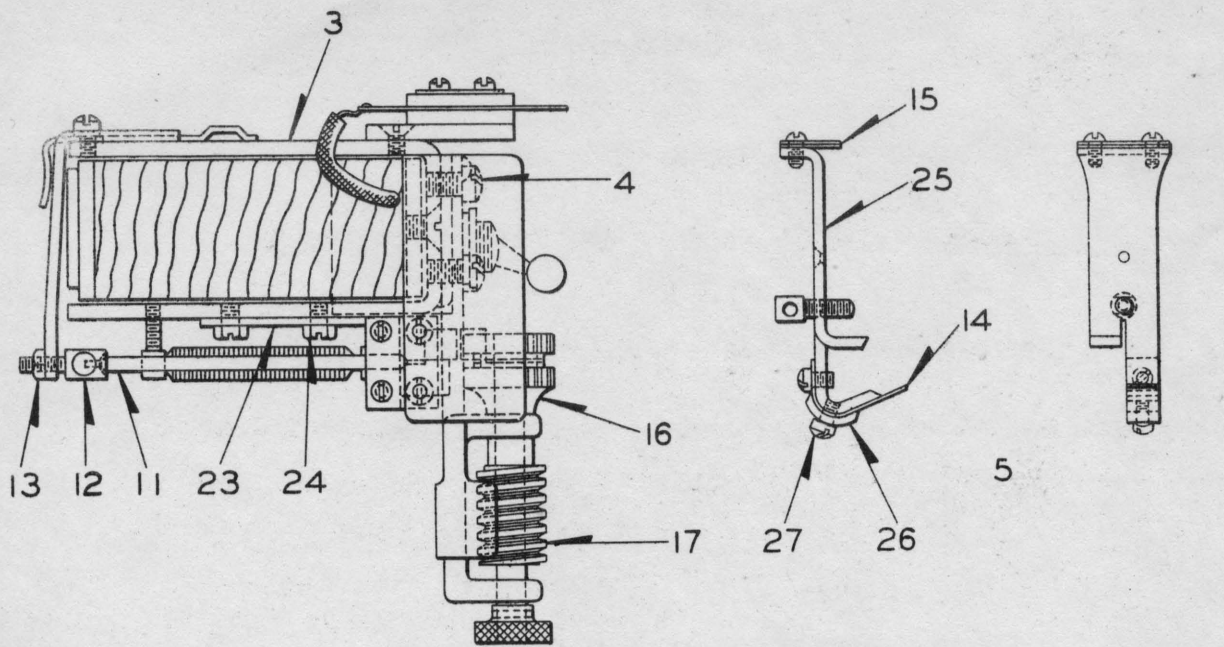

A

DRIVING MECHANISM

# UNION SWITCH & SIGNAL CO.

## CENTRALIZED TRAFFIC CONTROL SYSTEM

### DETAIL PARTS

#### DRIVING MECHANISM FOR TRAIN GRAPH

When ordering for replacement state Installation.

Order by Plate, Piece, Reference and Abbreviated Description Given in Heavy Face Type

Piece	Ref.	Description	Drawing Reference
	A	DRIVING MECHANISM for Train Graph	
164080	2	BRACKET.....	C-9348-7
	3	DRIVING MAGNET COMPLETE	
	4	MACHINE SCREW NO.10-30 x 3/8" Fil.Hd.S.(Cad.Pl.)	
189342	5	PAWL COMPLETE with Eye Bolt.....	9121-144
	6	MACHINE SCREW NO.2-56 x 1/4" Rd.Hd.S.(Cad.Pl.)	
185050	7	RATCHET STOP.....	9121-162
	8	MACHINE SCREW NO.2-64 x 3/16" Rd.Hd.Br.(N.P.)	
168112	9	EYE BOLT.....	8034-201
168111	10	COIL SPRING.....	7770-467
168110	11	DRIVE ROD.....	8097-417
168148	12	SCREW with Nut Ref.13.....	8114-769
1505	13	HEX.NUT for Ref.12.....	8109-11
185484	14	PAWL DRIVING SPRING.....	8735-722
430077	15	HINGE SPRING for Driving Pawl (Two Req'd. per pawl Ref.5).....	430077
168108	16	RATCHET COMPLETE.....	9121-147
	17	WORM	
48533	18	PIN.....	8097-665
168109	19	KNOB.....	8235-152
37951	20	PIN.....	8097-279
	21	TOGGLE SWITCH, NO.8945 XY with extra capacity wiper, one Hex. Nut and one Knurled Ring Nut	
	22	MACHINE SCREW, NO.4-36 x 1/4" Rd.Hd.Br.(N.P.)	
186443	23	STOP.....	11893-718



# UNION SWITCH & SIGNAL CO.

PIECE	REF.	DESCRIPTION	DWG. REF.
186444	24	SCREW.....	8098-987
168074	25	PAWL ARM.....	9121-144
185485	26	SPRING CLAMP.....	11893-578
	27	MACHINE SCREW, NO.4-48 x 3/16" Fil.Hd.S.(Cad.Pl.)	

7-35

PLATE T-69A UNION SWITCH & SIGNAL CO.

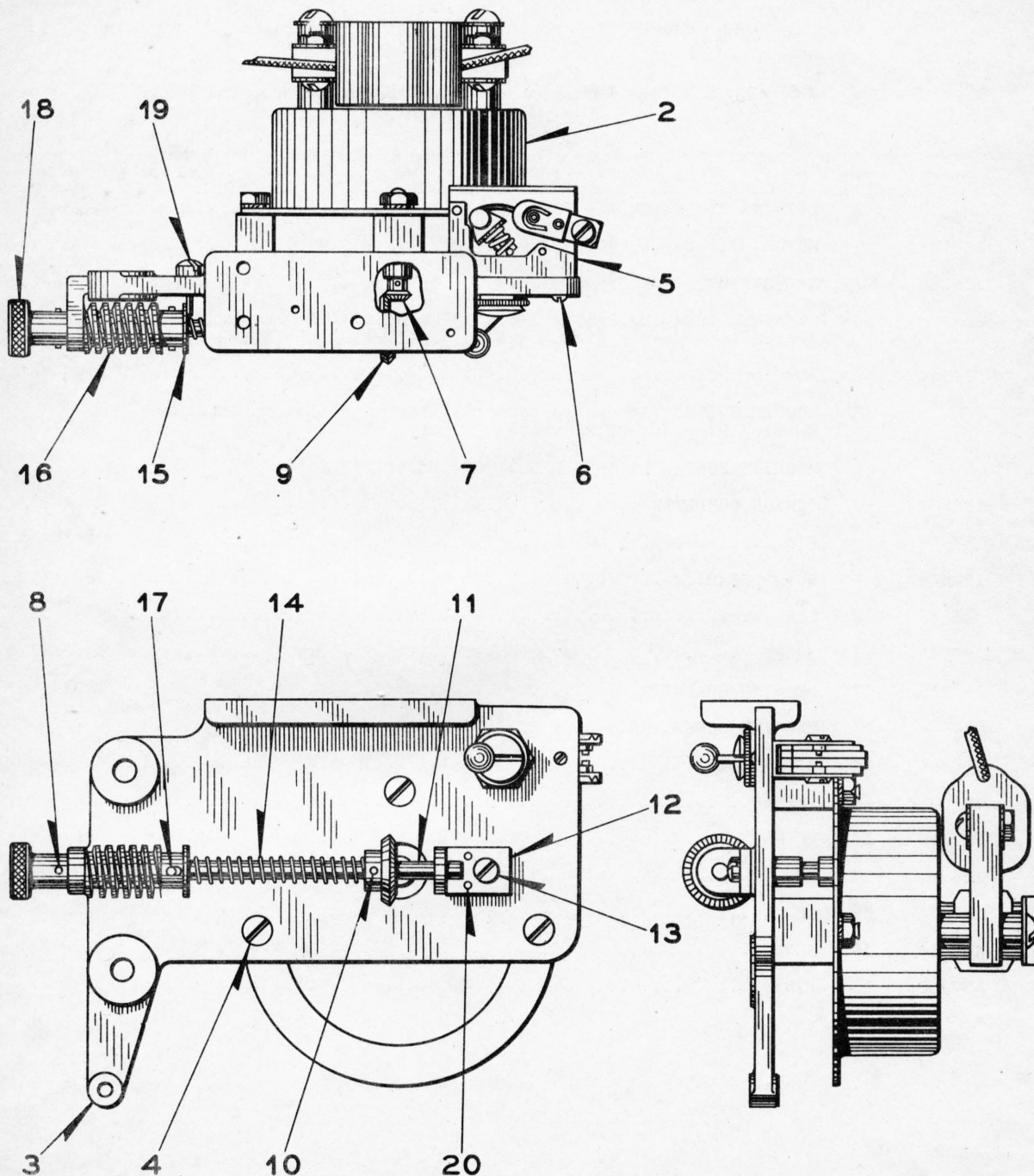

A

DRIVING MECHANISM



# UNION SWITCH & SIGNAL CO.

CENTRALIZED TRAFFIC CONTROL SYSTEM

DETAIL PARTS

DRIVING MECHANISM FOR TRAIN GRAPH

When ordering for replacement state Installation

**Order by Plate, Piece, Reference and Abbreviated Description Given in Heavy Face Type Only**

PIECE	REF.	DESCRIPTION	DWG. REF.
	A	DRIVING MECHANISM for Train Graph.....	C-9348-
102577	2	MOTOR, 110-Volts, 60-Cycles, 6-Watts, 1 R.P.M.....	C-9348-34
102560	3	END SUPPORT (R.H.Front).....	C-9348-33
	4	MACHINE SCREW, NO.8-36 x 1-1/8" Flat Hd.S. (Tin Pl.) with No. 8 Pl.S.Lock Washer (1/16" x 3/64") (Tin Pl.) and Nut Ref.4a	
94344	4a	NUT for Ref.4.....	8265-70
	5	TOGGLE SWITCH with extra capacity wiper, one Hex.Nut and one Knurled Ring Nut (C.N.72739)	
	6	MACHINE SCREW, NO.4-36 x 5/16" Rd.Hd.Br. (N.P.)	
102567	7	PINION COMPLETE.....	8424-293
37951	8	PIN.....	8097-279
102570	9	BEVEL GEAR.....	8424-294
41247	10	PIN.....	8097-362
102563	11	SHAFT.....	12501-125
183173	12	BEARING BRACKET.....	10914-537
	13	MACHINE SCREW, NO.8-36 x 5/16" Fl.Hd.S. (N.P.)	
208884	14	SPRING.....	7770-497
183037	15	WASHER.....	7826-272
102398	16	WORM.....	8424-291
208974	17	PIN.....	8097-466
183174	18	KNOB.....	8235-163
183036	19	SCREW.....	8378-361
37950	20	PIN.....	8097-279

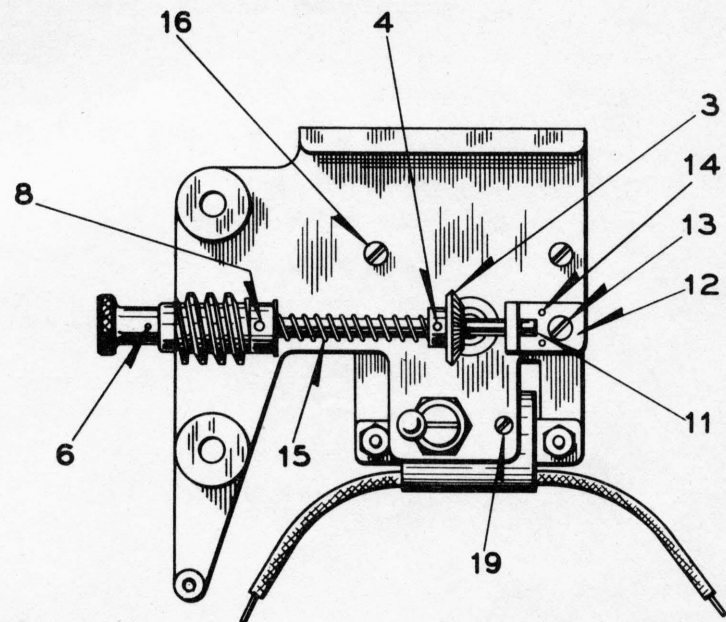
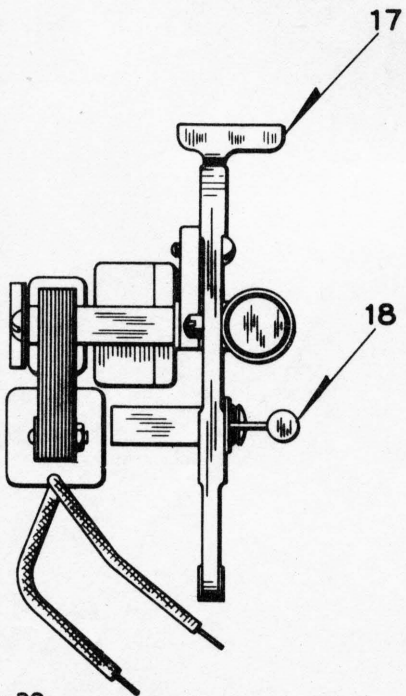
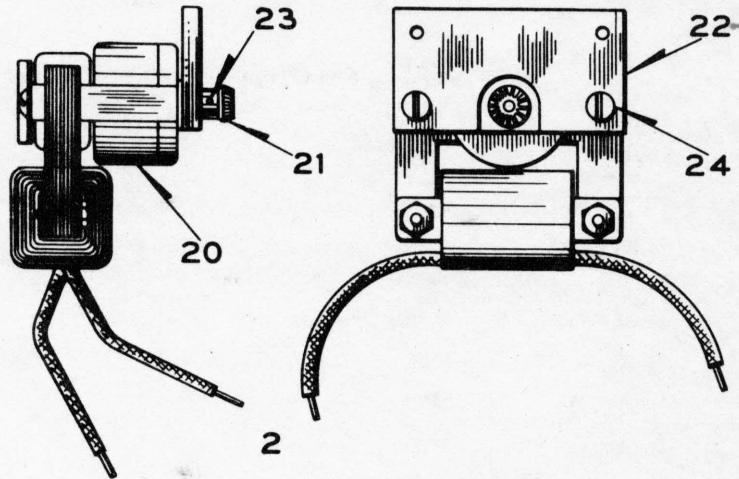
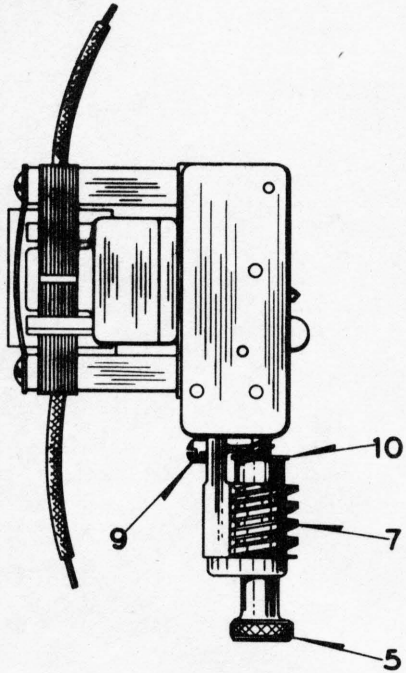

4-10-39

DRIVING MECHANISM FOR TRAIN GRAPH



# UNION SWITCH & SIGNAL CO.

CENTRALIZED TRAFFIC CONTROL SYSTEM

DETAIL PARTS

DRIVING MECHANISM FOR TRAIN GRAPH

When ordering for replacement state installation.

**Order by Plate, Piece, Reference and Abbreviated Description Given in Heavy Face Type Only**

PIECE	REF.	DESCRIPTION	DWG. REF.
	A	DRIVING MECHANISM FOR TRAIN GRAPHS shown on Plate T-68-A.....	C-9348-23
183189	2	MOTOR, 110-Volts, 60-Cycles, 4-Watts, 1 R.P.M. with Pinion Gear, Support Plate and Pin.....	C-9348-23
C.N.79583	3	BEVEL GEAR	
41247	4	PIN.....	8097-362
183174	5	KNOB.....	8235-163
37951	6	PIN.....	8097-279
C.N.79581	7	WORM	
168537	8	PIN.....	8097-643
183036	9	TRUNNION STOP SCREW.....	8378-361
183037	10	WASHER.....	7826-272
183035	11	DRIVE ROD.....	12501-89
183173	12	SUPPORT BRACKET.....	10914-537
	13	MACHINE SCREW, NO.8-36 x 5/16" Flt.Hd.S. (N.P.)	
37950	14	PIN.....	8097-279
183172	15	SPRING.....	7770-497
	16	MACHINE SCREW, NO.8-36 x 1/2" Rd.Hd.S. (N.P.)	
182177	17	END SUPPORT (R.H.Front).....	C-9348-22
C.N.72739	18	TOGGLE SWITCH COMPLETE	
	19	MACHINE SCREW, NO.4-36 x 1/4" Rd.Hd.Br. (N.P.)	
C.N.71762	20	MOTOR, 110-Volts, 60-Cycles, 4-Watts, 1 R.P.M. (Without Pinion Gear, Support Plate and Pin)	
C.N.79608	21	PINION GEAR	
183034	22	MOTOR SUPPORT PLATE.....	12538-113
39886	23	PIN.....	8097-362
	24	MACHINE SCREW, NO.10-32 x 1/2" Flat Hd.S. (N.P.)	

# PLATE T-69-C

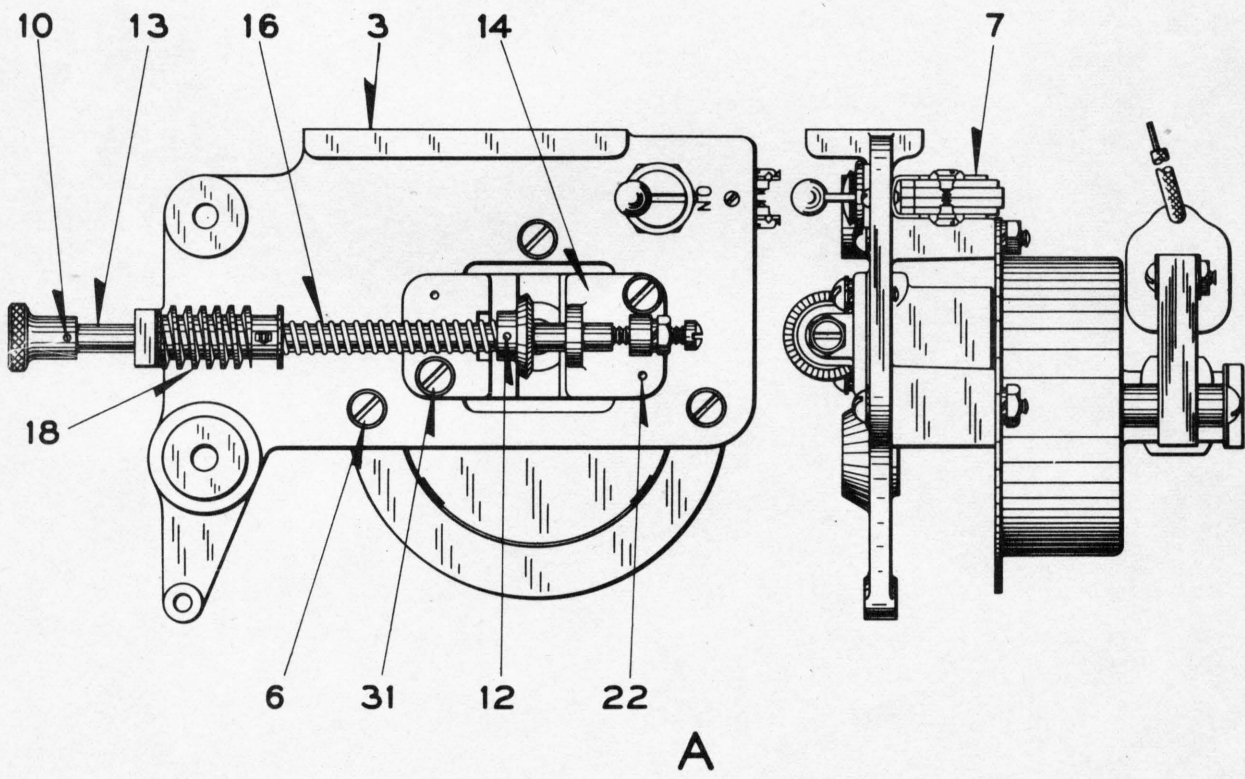
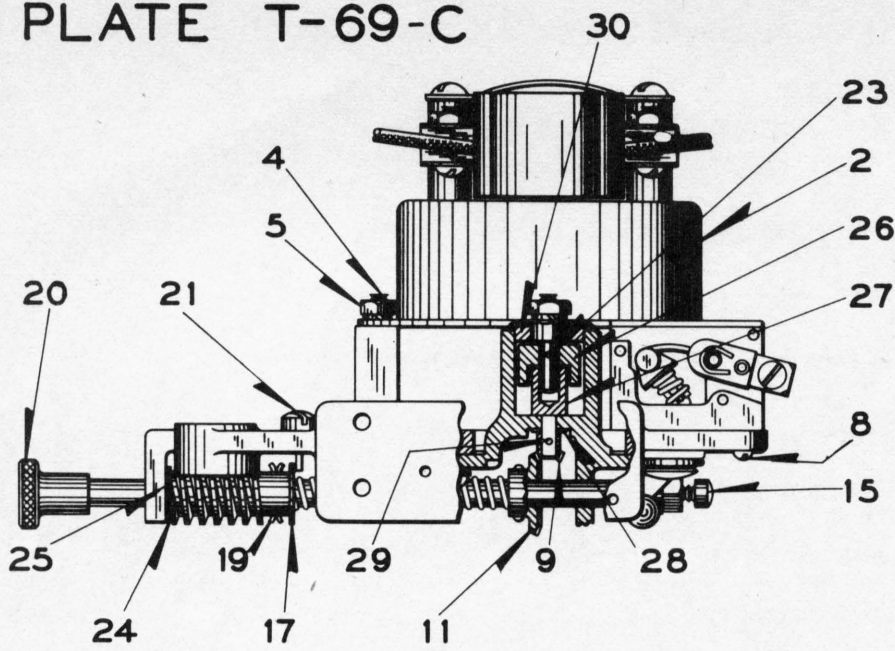

## DRIVING MECHANISM



# UNION SWITCH & SIGNAL CO.

## CENTRALIZED TRAFFIC CONTROL SYSTEM

### DETAIL PARTS

#### DRIVING MECHANISM FOR TRAIN GRAPH

When ordering for replacement state installation.

**Order by Plate, Piece, Reference and Abbreviated Description Given in Heavy Face Type Only**

PIECE	REF.	DESCRIPTION	DWG. REF.
221456	A	DRIVING MECHANISM FOR TRAIN GRAPH (With 110-120 Volts, 50-Cycle Motor Ref.2).....	C-9348-33
102561	Aa	DRIVING MECHANISM FOR TRAIN GRAPH (With 110-Volts, 60-Cycles Motor Ref.2a).....	C-9348-33
221455	2	MOTOR, 110-120 Volts, 50-Cycles.....	C-9348-34
102577	2a	MOTOR, 110-Volts, 60-Cycles.....	C-9348-34
102560	3	R.H.FRONT END SUPPORT.....	C-9348-33
	4	MACHINE SCREW, NO.8-36 x 1-1/2" Rd.Hd.S.(Tin Pl.) with No.8 Pl. S.Lock Washer (1/16" x 3/64") (Tin Pl.), Nut Ref.5 and Washer Ref.6	
94344	5	NUT.....	8265-70
102169	6	WASHER.....	7828-401
	7	TOGGLE SWITCH COMPLETE	
	8	MACHINE SCREW, NO.4-36 x 5/16" Rd.Hd.Br.(N.P.)	
102566	9	PINION GEAR.....	8424-293
45693	10	PIN.....	8097-473
102570	11	BEVEL GEAR.....	8424-294
36805	12	PIN.....	8097-279
102563	13	SHAFT.....	12501-125
220504	14	GEAR MOUNTING BRACKET.....	C-9348-21
	15	MACHINE SCREW, NO.8-36 x 5/8" Fil.Hd.S.(Tin Pl.) with No.8 Pl. S.Lock Washer (1/16" x 3/64") (Tin Pl.), and Nut Ref.5	
208884	16	SPRING.....	7770-497
183037	17	WASHER.....	7826-272
102398	18	WORM.....	8424-291
216008	19	PIN.....	8097-852
183174	20	KNOB.....	8235-163
183036	21	SCREW.....	8378-361
37950	22	PIN.....	8097-279
25949	23	PIN.....	8097-168
219962	24	WASHER (Steel).....	7826-300

# UNION SWITCH & SIGNAL Co.

PIECE	REF.	DESCRIPTION	DWG. REF.
219961	25	WASHER (Fibre).....	8078-549
221026	26	COUPLING PIECE (Motor End).....	12748-27
221027	27	COUPLING PIECE (Gear End).....	12748-27
221007	28	WASHER.....	8078-379
39886	29	PIN.....	8097-362
220892	30	GUIDE BUSHING.....	8350-964
	31	MACHINE SCREW, NO.8-36 x 7/16" Rd.Hd.Br.(N.P.) with Washer Ref.6 and No.8 Pl.S.Lock Washer (1/16" x 3/64") (Tin Pl.)	
3-31-41			



# UNION SWITCH & SIGNAL CO.

## PLATE T-71

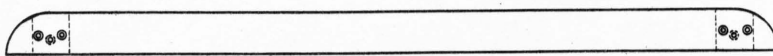
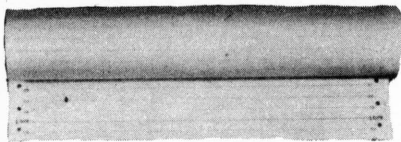
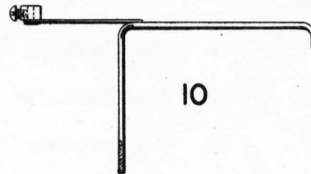
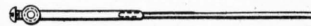
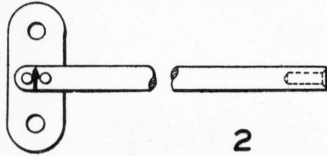
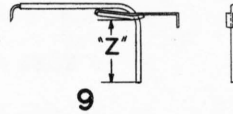
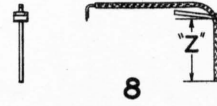
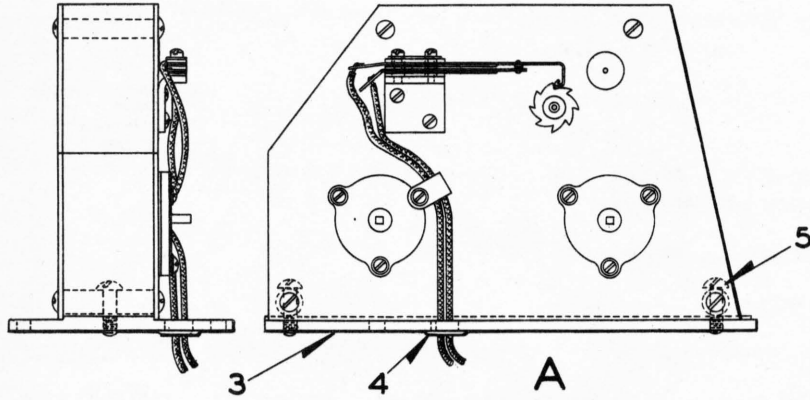
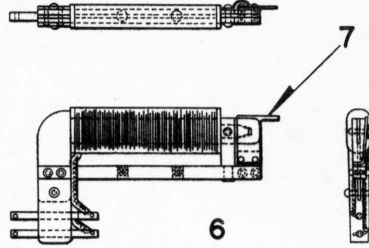
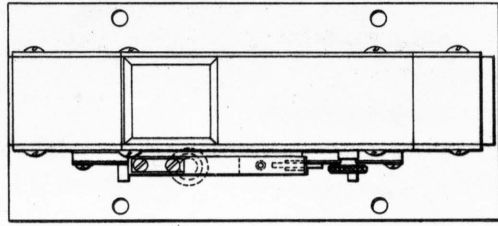

15

### TRAIN GRAPH DETAILS

# UNION SWITCH & SIGNAL CO.

## CENTRALIZED TRAFFIC CONTROL SYSTEM

### DETAIL PARTS

#### TRAIN GRAPH DETAILS

When ordering for replacement state installation

Order by Plate, Piece, Reference and Abbreviated Description Given in Heavy Face Type

Piece	Ref.	Description	Drawing Reference
	A	CONTROL MASTER CLOCK, (Without Key) (When ordering state installation for which required)	
	Aa	CONTROL MASTER CLOCK, (Without Key) Wall Type (Not shown)	
	2	KEY ONLY for Ref.A	
170238	3	BASE ONLY for Ref.A.....	12538-86
171312	4	BUSHING for Ref.A.....	8100-204
	5	MACHINE SCREW NO.10-30 x 5/8" Fil.Hd.Br.(W.P.) for Ref.A	
	6	PEN MAGNET COMPLETE, flat coil type	
168059	7	ARMATURE for Pen Magnet.....	8157-384
168082	8	ESTERLINE GRAPHIC METER PEN "Z" Dim. 3/4".(Pilot Pen).....	12681-2
168084	9	PEN COMPLETE "Z" Dim. 7/8".....	12681-3
157615	10	DEEP WELL PEN. (Bristol).....	12681-1
	11	CHART PAPER, 200-Ft. Roll U.S.& S.Co.	
	12	PEN FILLER (Esterline Angus Co.)	
	13	BROWN RECORDING INK (Color Green) Furnished in 1/2 Pint bottles	
	14	GRAPH RECORDER NAME PLATE ETCHING (When ordering, orders should state lettering desired)	
	15	RETAINER, for graph recorder name plate etching.	

5-32  
7-25



# PLATE T-75

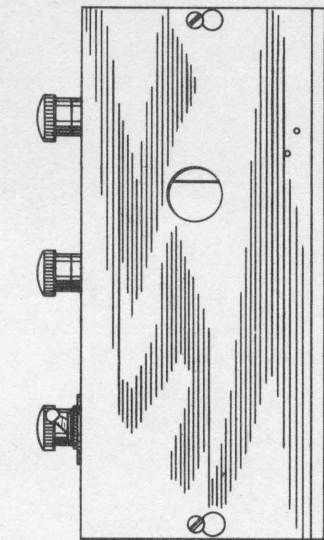
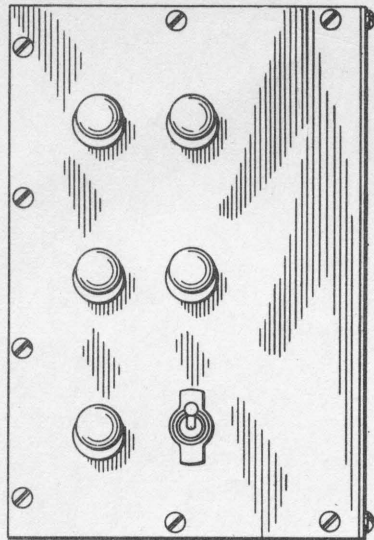

A

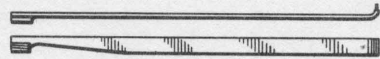

4

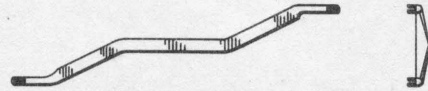

5

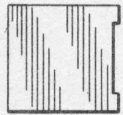
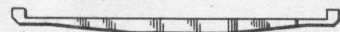

8



7

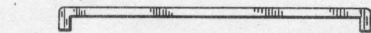

6

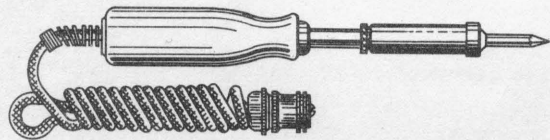
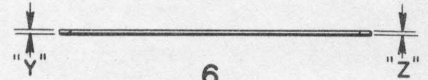

9

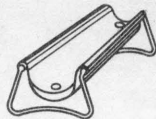

10



11

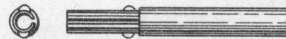

13

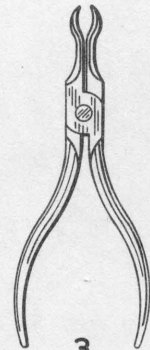

3

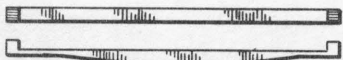

14



19

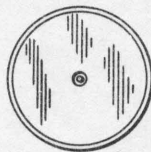

18

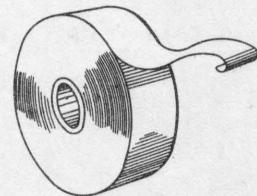
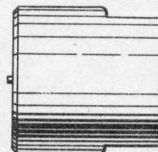

2

## CYCLE RECORDER, TOOLS AND SUPPLIES

# UNION SWITCH & SIGNAL CO.

## CENTRALIZED TRAFFIC CONTROL SYSTEM

### DETAIL PARTS

#### CYCLE RECORDER, TOOLS AND SUPPLIES FOR MAINTENANCE

Order by Plate, Piece, Reference and Abbreviated Description Given in Heavy Face Type Only

PIECE	REF.	DESCRIPTION	DWG. REF.
	A	CYCLE RECORDER (When ordering state installation for which required).	
	2	ROLL SIZE "C" PAPER FOR CYCLE RECORDER	
	3	PLIERS for removing Lamp Caps	
	4	OFFSET SCREW DRIVER for removing Relay Armatures	
164375	5	BENDER for Contact Springs.....	A-2586-15
164376	6	GAUGE for Contact Springs, "y"- .028" and "z"- .040".....	A-2586-15
171608	6a	GAUGE for Contact Springs, "y"- .035" and "z"- .045".....	A-2586-15
164377	7	SWEDGE for Adjusting Relay Armatures.....	A-2586-15
164393	8	ANVIL for Adjusting Relay Armatures.....	A-2586-16
	9	3/8" ELECTRIC SOLDERING IRON with stand.	
	10	NO.22 B.& S. GAUGE SOLID COPPER WIRE in color code for wiring control machine and control units (Orders should specify quantity and color desired).	
	11	NO.20 B.& S. GAUGE FLEXIBLE COPPER WIRE in color code for wiring control machine and control units (Orders should specify quantity and color desired).	
177803	13	TOOL for Removing Lamps.....	A-2586-21
172481	14	BENDER (STRAIGHT) for Contact Springs.....	A-2586-14
	15	GRAM GAUGE W.E. 68B for measuring contact pressures (Not shown)	
	16	BURNISHING TOOL W.E. 265B for cleaning contacts (Not shown)	
	17	RESIN CORE SOLDER for making soldered connections (Do not use acid core or acid soldering paste or fluid).	
106100	18	ANVIL (Used to form Eyelets on Relay Armatures).....	A-2586-34
106099	19	PUNCH (Used to form Eyelets on Relay Armatures).....	A-2586-34



# UNION SWITCH & SIGNAL CO.

PLATE T - 77

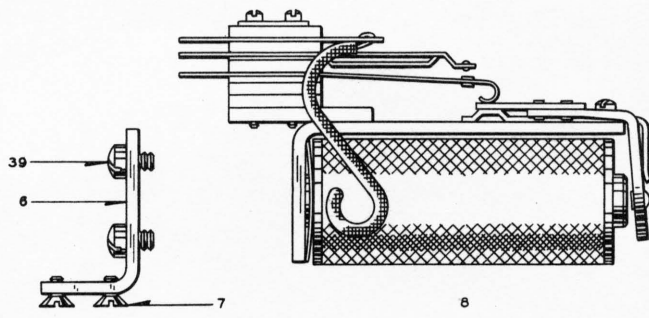
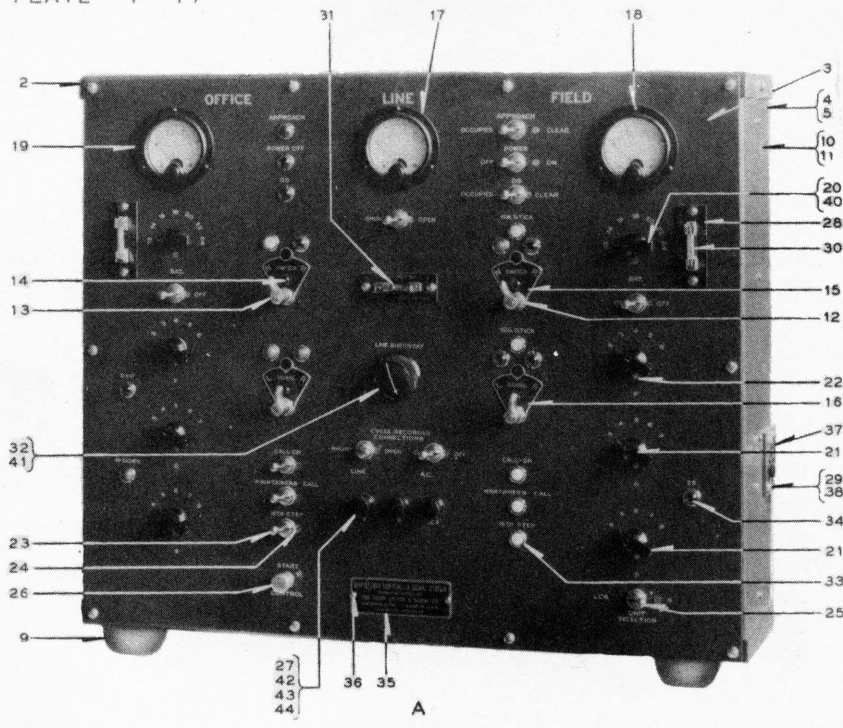

8-38

OFFICE AND FIELD TEST SET

## UNION SWITCH &amp; SIGNAL CO.

## CENTRALIZED TRAFFIC CONTROL SYSTEM

## DETAIL PARTS

## OFFICE AND FIELD TEST SET

Order by Plate, Piece, Reference and Abbreviated Description Given in  
Heavy Face Type Only

PIECE	REF.	DESCRIPTION	DWG. REF.
102696	A	OFFICE AND FIELD TEST SET COMPLETE (With 50 Milliampere Meter) for Centralized Traffic Control System Time Code Scheme.....	D-2491-2
102793	Aa	OFFICE AND FIELD TEST SET COMPLETE (With 150 Milliampere Meter) for Centralized Traffic Control System Time Code Scheme.....	D-2491-2
100459	2	CASE COMPLETE.....	C-9428-8
102695	3	FRONT PLATE.....	C-9428-10
161842	4	BACK PLATE COMPLETE.....	C-9248-56
	5	MACHINE SCREW, NO.10-30 x 1/4" Rd.Hd.S. (Head painted Olive Green) for attaching back plate to case	
184994	6	RELAY BRACKET.....	10914-573
	7	MACHINE SCREW, NO.6-40 x 1/4" Flat Hd.Br. (N.P.)	
172827	8	RELAY COMPLETE (For details refer to Plate T-54).....	B-12660-13
176508	9	RUBBER SUPPORT.....	8078-1524
199731	10	CABLE ROD.....	8114-439
	11	MACHINE SCREW, NO.10-30 x 3/8" Flat Hd.S.(Head painted Olive Green) for attaching Cable Rod to Case also bottom of Back Plate to Case	
171586	12	SWITCH AND SIGNAL CONTROLLER COMPLETE (For details refer to Plate T-21).....	B-12670-8
171454	13	SWITCH CONTROLLER COMPLETE (For details refer to Plate T-21)..	B-12670-8
	14	MACHINE SCREW, NO.6-40 x 1/4" Rd.Hd.Br. (N.P.)	
160051	15	SWITCH NUMBER PLATE.....	8225-341
160053	16	SIGNAL NUMBER PLATE.....	8225-341
	17	METER, D.C. 50 Milliampere, for Ref.A, with Screws and Nuts	
	17a	METER, D.C. 150 Milliampere, for Ref.Aa, with Screws and Nuts	
	18	MACHINE SCREW, 4-40 x 3/4" Rd.Hd.Bz. with Sq.Nut	
	19	VOLTMETER, D.C. 0-30 Volts	
100465	20	SWITCH (For 7 position operation).....	9954-68
100466	21	SWITCH (For 5 position operation).....	9954-69
	22	MACHINE SCREW, NO.4-48 x 1/4" Flat Hd.Br. (N.P.)	
	23	TOGGLE SWITCH (C.No.72739)	
	24	MACHINE SCREW, NO.4-40 x 1/2" Flat Hd.Br. (N.P.)	



# UNION SWITCH & SIGNAL CO.

PIECE	REF.	DESCRIPTION	DWG. REF.
	25	TOGGLE SWITCH (C.No.72758)	
171554	26	PUSH BUTTON COMPLETE (For details refer to Plate T-21).....	B-9918-47
	27	BINDING POST with Nuts and Washers (Inc.1-27a, 2-42, 3-43 and 1-44)	
	27a	BINDING POST with One Nut and Terminal (C.No.71961)	
	28	FUSE BLOCK (C.No.70292)	
20686	29	WASHER.....	7828-108
	30	FUSE, 10-Amp. 250-V. (C.No.71153)	
	31	FUSE, .125-Amp. 250-V. (C.No.71157)	
	32	RHEOSTAT, 500-Ohms, 50-Watts (C.No.62099)	
154829	33	LAMP RECEPTACLE COMPLETE (For details refer to Plate T-20).....	12522-14
	34	LAMP CAP (When ordering refer to Plate T-20).....	12522-11
150399	35	NAME PLATE.....	8225-317
	36	DRIVE SCREW, NO.2 x 3/16" Rd.Hd.Hardened (Tin Pl.)	
175223	37	INSULATION.....	8750-2511
	38	MACHINE SCREW NO.6-40 x 3/8" Rd.Hd.S. (N.P.)	
	39	MACHINE SCREW, NO.10-30 x 1/4" Fil.Hd.S. (N.P.)	
48800	40	WASHER (Used between switch and back of face plate).....	7828-184
43782	41	COLLAR (Used between rheostat and back of face plate).....	8350-411
1535	42	NUT.....	8109-38
17376	43	WASHER.....	7828-66
	44	LOCK WASHER, NO.8 Pl.S. (1/16" x 3/64") (Tin Pl.)	
141452	45	TAG (Order should specify marking desired) (Not shown).....	8988-71
184689	46	MIDDLE PLUG CONNECTOR COMPLETE with twenty-five Contact Springs and Terminal Posts (Not shown) for Station Coding Unit (Numbered 26 to 50).....	C-9232-51
184690	46a	L.H. PLUG CONNECTOR COMPLETE with twenty-five Contact Springs and Terminal Posts (Not shown) for Station Coding and Storage Units (Numbered 1 to 25).....	C-9232-51
184691	46b	R.H. PLUG CONNECTOR COMPLETE with twenty-five Contact Springs and Terminal Posts (Not shown) for Station Storage Unit (Numbered 26 to 50).....	C-9232-51
101931	46c	R.H. PLUG CONNECTOR COMPLETE with thirty Contact Springs and Terminal Posts (Not shown) for L.C.S. Unit (Numbered 51 to 80)	C-9232-105
101782	46d	PLUG CONNECTOR COMPLETE with five Contact Springs and Terminal Posts (Not shown) for "P-4" Relays (Numbered +, -, B, H, F)...	C-16642-2

# UNION SWITCH & SIGNAL CO.

## PLATE T-80

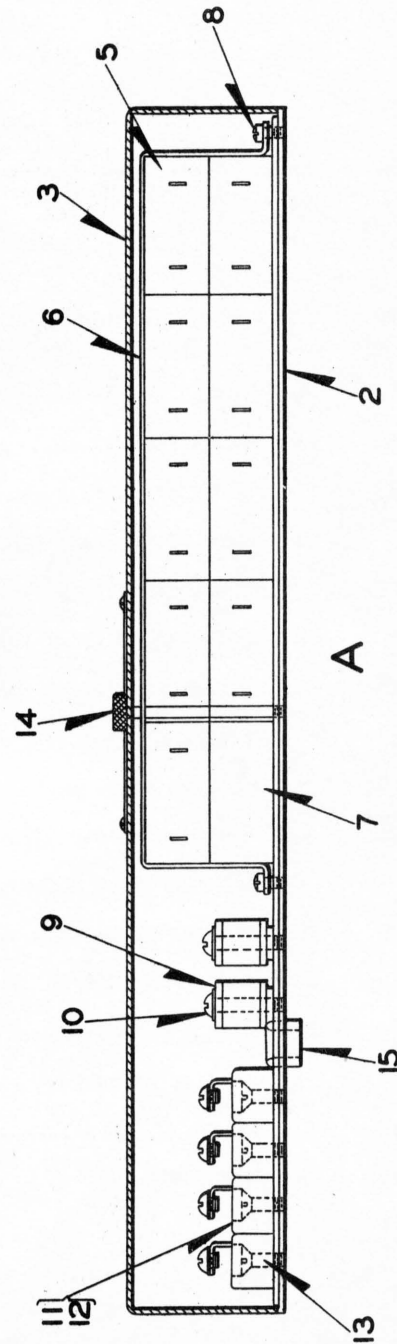
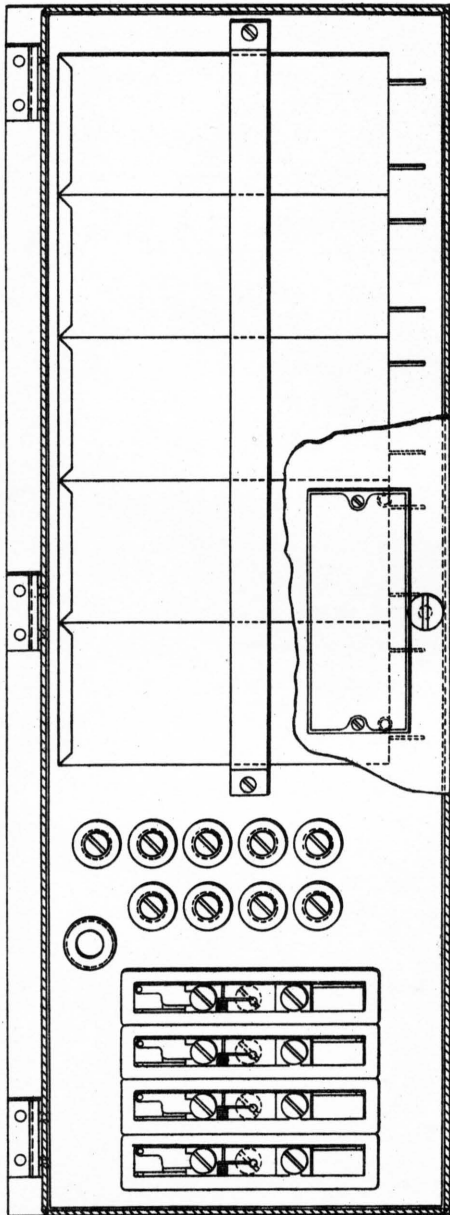
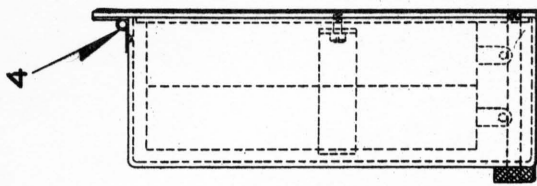

A  
CONDENSER CASE



# UNION SWITCH & SIGNAL CO.

## CENTRALIZED TRAFFIC CONTROL SYSTEM

### DETAIL PARTS

#### CONDENSER CASE

For application to coding units of 27 Station Basis.

Order by Plate, Piece, Reference and Abbreviated Description Given in Heavy Face Type

Piece	Ref.	Description	Drawing Reference
180012	A	CONDENSER CASE COMPLETE, (using 9 Condensers) as shown, for Field Coding Unit.....	C-9232-87
180010	Aa	CONDENSER CASE COMPLETE, (using 8 Condensers) for Office Coding Unit.....	C-9232-87
178735	2	BASE, for Ref.A.....	C-9232-86
179154	2a	BASE, for Ref.Aa.....	C-9232-86
179585	3	COVER for Refs.2 and 2a.....	C-9232-88
	4	BUTT HINGE 3/4" x 3/4" with four 1/8" x 1/4" Csk.Hd.I.Rivets	
168916	5	CONDENSER.....	B-12549-15
179917	6	CONDENSER SUPPORT for Ref.A.....	10914-474
179916	6a	CONDENSER SUPPORT for Ref.Aa.....	10914-474
169062	7	FILLER BLOCK.....	12443-180
	8	MACHINE SCREW NO.6-40 x 1/4" Fil.Hd.S.(Cad.Pl.)	
179793	9	RESISTOR (5 Ohms).....	9065-234
	10	MACHINE SCREW NO.10-30 x 1" Rd.Hd.S. with Washer Ref.10a	
73129	10a	WASHER for Ref.10.....	7826-180
	11	PORCELAIN FUSE BLOCK.	
	12	FUSE (1-1/3 Amp.)	
	13	MACHINE SCREW NO.10-30 x 5/8" Flat Hd.S.(Cad.Pl.)	
179742	14	SCREW.....	8098-1093
12196	15	BUSHING.....	8100-146

# UNION SWITCH & SIGNAL CO.

PLATE T-83

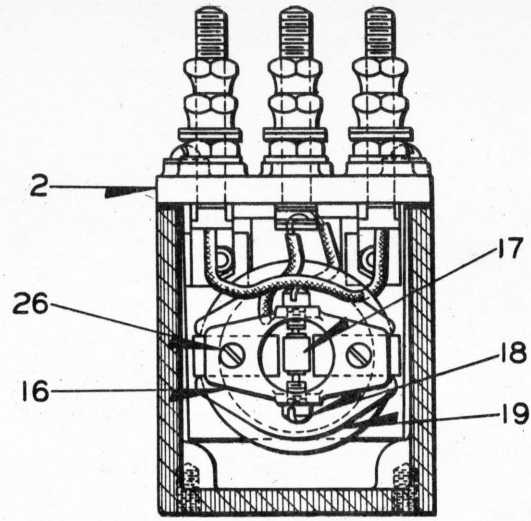
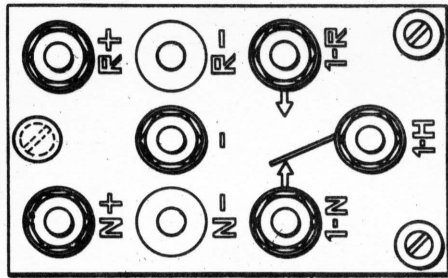

VIEW LOOKING IN DIRECTION OF ARROW

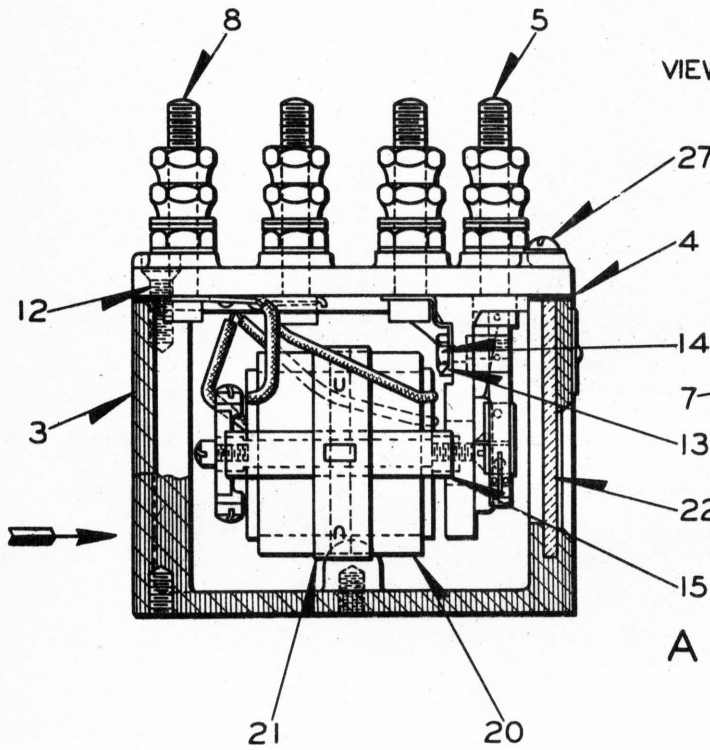

A

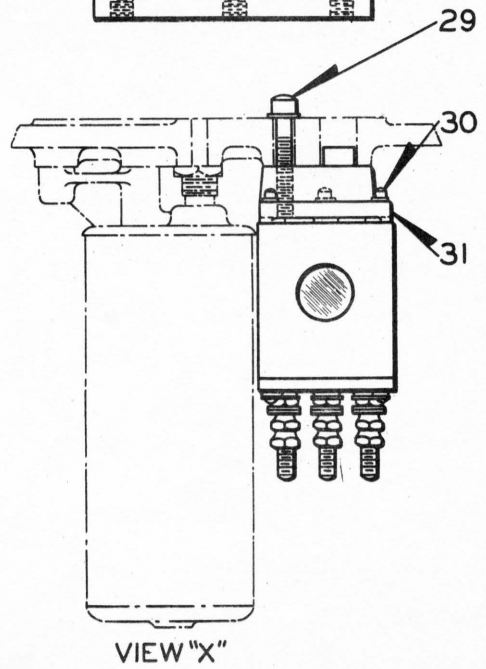
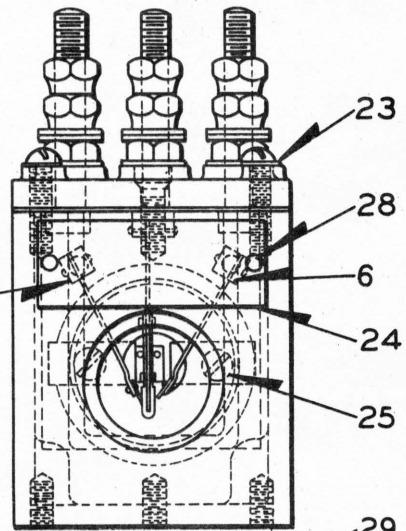

VIEW "X"

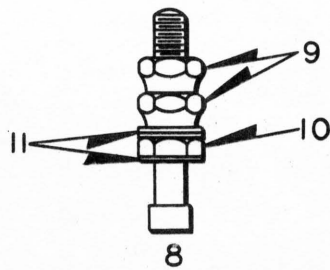
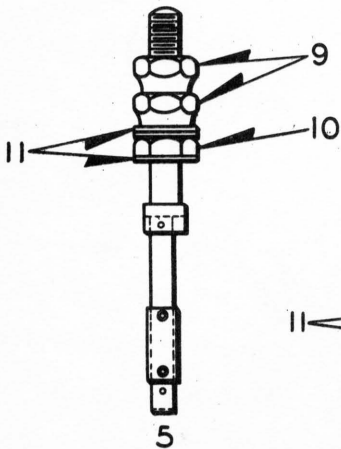

STYLE "P-3" POLAR RELAY



## UNION SWITCH &amp; SIGNAL CO.

STYLE "P-3" POLAR RELAY

Order by Plate, Piece, Reference and Abbreviated Description Given in  
Heavy Face Type Only

Piece	Ref.	Description	Drawing Reference
178517	A	STYLE "P-3" POLAR RELAY COMPLETE, 225 ohms per winding.....	B-12647-3
183419	Aa	STYLE "P-3" POLAR RELAY COMPLETE, 225 ohms per winding (With Name Plate Assembled Upside Down) for applying to "EP-14" Machines as per View "X".....	B-12647-3
187213	Ab	STYLE "P-3" POLAR RELAY COMPLETE, 375 ohms per winding (With Name Plate Assembled Upside Down) for applying to "EP-14" Machines as per View "X".....	B-12647-3
178079	2	TOP PLATE.....	B-12705-2
178515	3	CASE.....	B-12705-1
178323	4	GASKET, used between Refs.2 and 3.....	8078-1536
	5	CONTACT SPRING AND TERMINAL POST COMPLETE, with Rivet, Nuts, and Washers (Inc.1-5a, 2-9, 1-10 and 3-11).....	12451-
178319	5a	CONTACT SPRING AND TERMINAL POST COMPLETE, with Rivet (without Nuts and Washers) for Ref.5.....	8385-2316
178443	6	CONTACT SPRING (R.H.) COMPLETE, with Terminal Post and Rivet..	8385-2315
178363	7	CONTACT SPRING (L.H.) COMPLETE, with Terminal Post and Rivet..	8385-2315
	8	TERMINAL POST with Nuts and Washers (Inc.1-8a, 2-9, 1-10 and 3-11).....	12451-
160475	8a	TERMINAL POST ONLY, for Ref.8.....	8094-2207
29101	9	NUT.....	8109-193
29103	10	NUT.....	8109-194
29102	11	WASHER.....	7828-139
178306	12	SCREW.....	8098-1089
178499	13	TERMINAL CONNECTOR.....	8244-148
29956	14	NUT.....	8109-202
148190	15	POLE PIECE.....	8250-79
148191	16	ARMATURE SUPPORT.....	8303-102

# UNION SWITCH & SIGNAL CO.

PIECE	REF.	DESCRIPTION	DWG. REF.
178305	17	ARMATURE COMPLETE, with Pivot and Pins.....	8157-398
148181	18	SET SCREW.....	8378-350
178362	19	COIL COMPLETE with Leads (225 ohms per winding).....	8133-417
187212	19a	COIL COMPLETE with Leads (375 ohms per winding).....	8133-417
148189	20	PERMANENT MAGNET.....	12586-6
148311	21	MAGNET HOLDER.....	11893-396
178361	22	GLASS SHIELD.....	8163-212
17376	23	WASHER.....	7828-66
178360	24	NAME PLATE.....	8225-413
	25	MACHINE SCREW NO.8-36 x 7/16" Flat Hd.S.(Tin Pl.)	
	26	MACHINE SCREW NO.8-36 x 1/4" Rd.Hd.S.(Tin Pl.)	
	27	MACHINE SCREW NO.8-36 x 3/4" Rd.Hd.Br.(N.P.)	
	28	SCREW, NO.4 x 1/4" Rd.Hd.Hardened	
	29	MACHINE SCREW 5/16"-18 x 1-3/8" Fil.Hd.S.with 5/16" Plain S. Lock Washer (1/16" x 1/16") for fastening Ref.31 to "EP-14" Machine.	
	30	MACHINE SCREW NO.8-36 x 3/4" Fil.Hd.Br. with 3/16" Plain S. Lock Washer (1/16" x 1/16") for fastening Ref.31 to Relay.	
180011	31	ADAPTER BRACKET for mounting relay.....	B-12705-3

11-1-33



PLATE T - 84

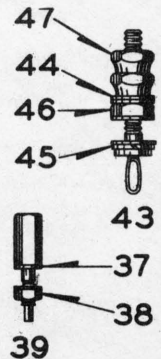
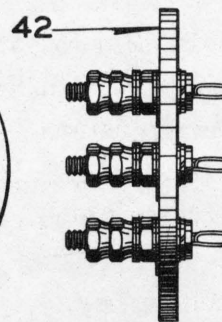
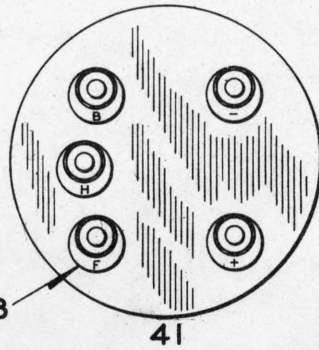
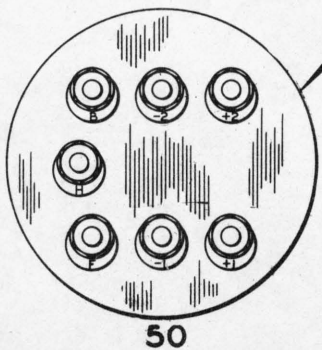
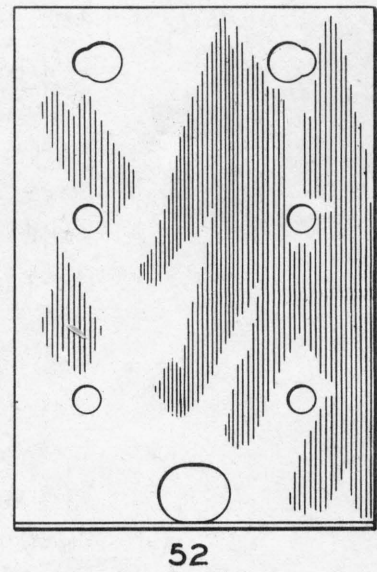
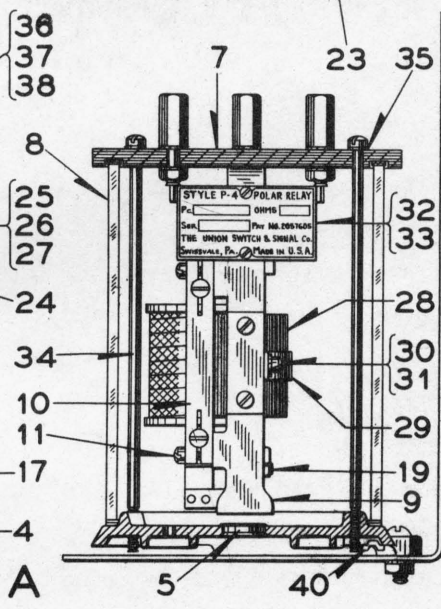
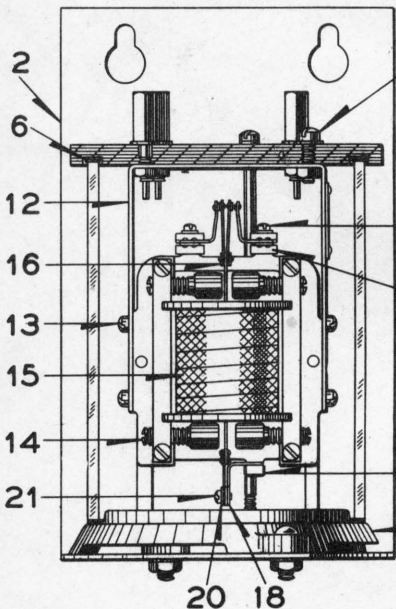
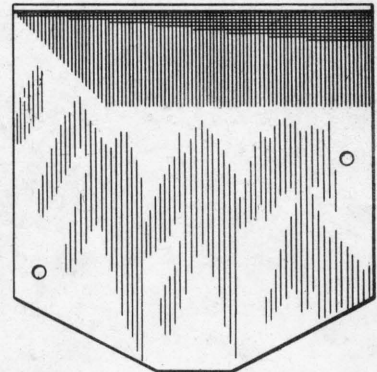
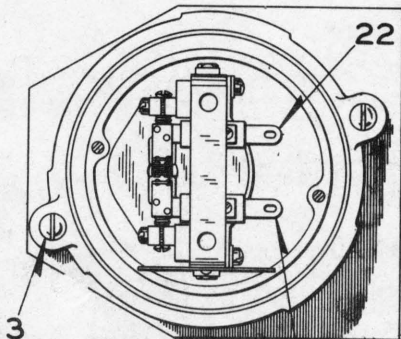
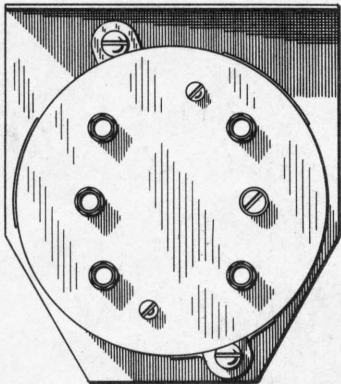
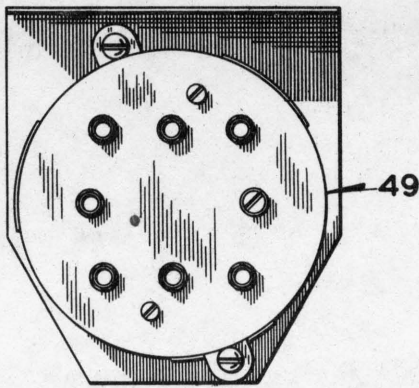
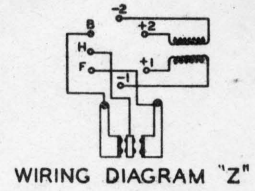
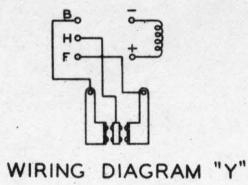

## UNION SWITCH &amp; SIGNAL CO.

## STYLE "P-4" BIASED POLAR RELAY

Order by Plate, Piece, Reference and Abbreviated Description Given in  
Heavy Face Type Only

PIECE	REF.	DESCRIPTION	DWG. REF.
101703	A	STYLE "P-4" POLAR RELAY COMPLETE as shown, with Wall Bracket, Plug Connector Ref.41 (19-Ohm Magnet Coil) and wired per Diag."Y".....	C-16643-1
101614	Aa	STYLE "P-4" POLAR RELAY COMPLETE, with 19-Ohm Magnet Coil, Plug Connector Ref.41, and wired per Diag."Y" (Without Wall Bracket) for Ref.A.....	C-16643-1
209195	Ab	STYLE "P-4" POLAR RELAY COMPLETE, (Top plate arranged as per "X"), with Wall Bracket, Plug Connector Ref.50 (8.5-Ohm Magnet Coil) and wired per Diag."Z".....	C-16643-2
209175	Ac	STYLE "P-4" POLAR RELAY COMPLETE, (Top plate arranged as per View "X") with 8.5-Ohm Magnet Coil, Plug Connector Ref.50, and wired per View "Z" (without Wall Bracket) for Ref.Ab.....	C-16643-2
192338	2	WALL BRACKET.....	10914-663
	3	MACHINE SCREW, NO.10-30 x 5/8" Rd.Hd.S. (Tin Pl.) with No.10 Lock Washer (Internal Teeth) (Tin Pl.) and No.10-30 S.Hex.Nut (Tin Pl.)	
171428	4	BASE with Ventilator and Gasket.....	B-12577-1
34340	5	VENTILATOR for Ref.4.....	C-7459-6
116925	6	GASKET for Refs.4 and 7.....	8078-514
	7	TOP PLATE with Gasket for Refs.A and Aa.....	C-16642-2
130616	8	SHIELD.....	8163-49
101617	9	RELAY MOUNTING FRAME.....	C-16642-1
101618	10	BACK STRAP.....	8162-265
	11	MACHINE SCREW, NO.6-40 x 5/8" Fil.Hd.S. (Tin Pl.)	
101637	12	MOUNTING BRACKET.....	10914-845
	13	MACHINE SCREW, NO.6-40 x 5/16" Fil.Hd.S. (Tin.Pl.)	
101622	14	POLE PIECE.....	8250-110
100897	15	MAGNET COIL COMPLETE (19-Ohms) for Refs.A and Aa.....	8133-397
102667	15a	MAGNET COIL COMPLETE (8.5-Ohms) for Refs.Ab and Ac.....	8133-504
101624	16	ARMATURE COMPLETE.....	8157-440
162755	17	SCREW.....	8098-165
101638	18	ARMATURE SUPPORT.....	11893-814
206801	19	NUT LOCK.....	8486-399
101636	20	CLAMP PLATE.....	12538-176



# UNION SWITCH & SIGNAL CO

PIECE	REF.	DESCRIPTION	DWG. REF.
	21	MACHINE SCREW, NO.3-56 x 1/8" Fil.Hd.Br. (N.P.)	
101644	22	L.H. CONTACT SPRING COMPLETE.....	8385-2526
101646	23	R.H. CONTACT SPRING COMPLETE.....	8385-2526
174235	24	INSULATION.....	8750-2503
206977	25	BUSHING.....	B-10266-1
152720	26	WASHER.....	7828-275
	27	MACHINE SCREW, NO.3-56 x 1/2" Fil.Hd.S. (N.P.)	
101635	28	PERMANENT MAGNET.....	12586-13
101560	29	PERMANENT MAGNET CLAMP.....	10914-849
	30	MACHINE SCREW, NO.6-40 x 7/16" Fil.Hd.Br. (N.P.)	
20686	31	WASHER.....	7828-108
101613	32	NAME PLATE.....	8225-505
	33	MACHINE SCREW, NO.2-56 x 1/8" Rd.Hd.Br. (N.P.)	
101829	34	SCREW.....	8098-1425
195397	35	WASHER.....	7828-368
	36	MACHINE SCREW, NO.10-30 x 9/16" Fil.Hd.Br. (N.P.) with one Washer Ref.37 and one Nut Ref.38	
44618	37	WASHER.....	7828-184
26942	38	NUT.....	8109-184
	39	TERMINAL POST with Nut and Washers (Inc.1-39b, 2-37 and 1-38).	12451-
	39a	TERMINAL POST with Nut and Washer (Inc.1-39b, 1-37 and 1-38)..	12451-
153972	39b	TERMINAL POST ONLY, for Refs.39 and 39a.....	8094-2220
152702	40	SEAL with wire 9" long.....	8988-33
101782	41	PLUG CONNECTOR COMPLETE for Refs.A and Aa.....	C-16642-2
101781	42	PLUG CONNECTOR BOARD for Ref.41.....	C-16642-2
	43	CONTACT SPRING AND TERMINAL POST with Nuts and Washers (Inc. 1-43a, 4-44, 1-45, 1-46 and 2-47).....	12451-
154506	43a	CONTACT SPRING AND TERMINAL POST.....	8385-2174
29102	44	WASHER.....	7828-139
	45	1/4" PL.S.LOCK WASHER (3/32" x 1/16") (Tin Pl.)	
127260	46	NUT.....	8109-194
29101	47	NUT.....	8109-193
142777	48	TAG (Orders should specify marking desired).....	8988-75
	49	TOP PLATE with Gasket for Refs.Ab and Ac.....	C-16642-3
102675	50	PLUG CONNECTOR COMPLETE for Refs.Ab and Ac.....	C-16642-3
102674	51	PLUG CONNECTOR BOARD, for Ref.50.....	C-16642-3
102701	52	BRACKET for attaching Relay to Office Line Coding Unit.....	10914-883

UNION SWITCH & SIGNAL CO.

# PLATE T-85

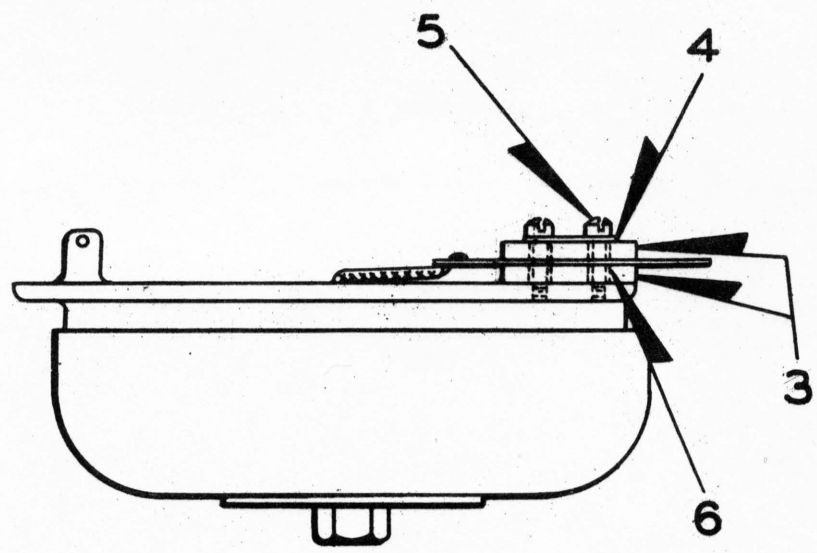
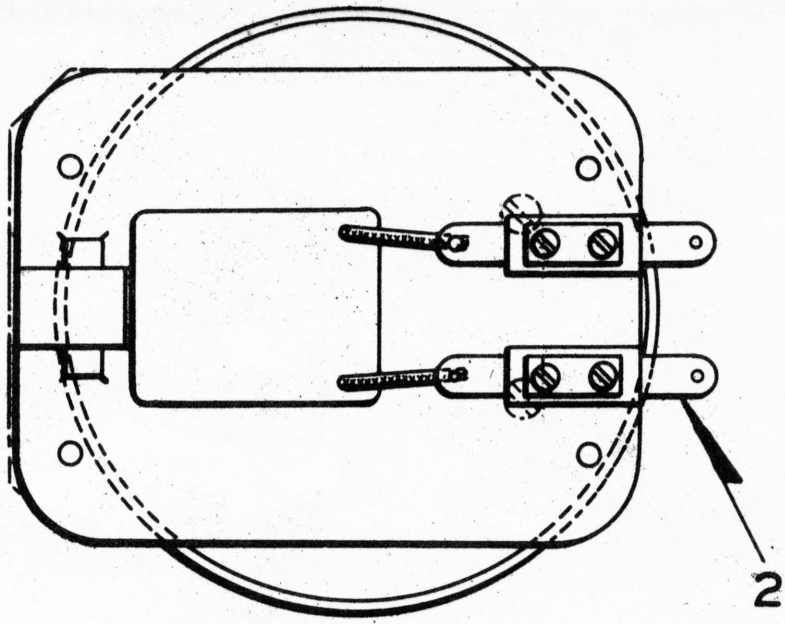

A

## BELLS



## UNION SWITCH &amp; SIGNAL CO.

## CENTRALIZED TRAFFIC CONTROL SYSTEM

## DETAIL PARTS

## BELLS

Order by Plate, Piece, Reference and Abbreviated Description Given in  
Heavy Face Type

Piece	Ref.	Description	Drawing Reference
156935	A	SINGLE STROKE BELL, Type D.S.-4, Standard Tone (25 ohms resistance for 12 Volt D.C.Operation).....	B-12680-1
156936	Aa	SINGLE STROKE BELL, Type D.S.-4-2, Soft Tone (25 ohms resistance for 12 Volt D.C.Operation).....	B-12680-1
173881	Ab	SINGLE STROKE BELL, Type D.S.-4, Standard Tone (25 ohms resistance for 16 Volt D.C.Operation).....	B-12680-1
183359	Ac	SINGLE STROKE BELL, Type D.S.-4, Standard Tone (6.54 ohms resistance for 6 Volt D.C.Operation).....	B-12680-1
	Ad	VIBRATING BELL, Type DV-4, 4" Gong (24 Volt D.C.).....	B-12680-2
152721	2	COIL CONNECTOR.....	8064-663
174235	3	INSULATION.....	8750-2503
152720	4	WASHER.....	7828-275
	5	MACHINE SCREW NO.3-56 x 7/16" Fil.Hd.S.(N.P.)	
152731	6	BUSHING.....	B-10266-1





**GENERAL OFFICE AND WORKS**  
**SWISSVALE, PA.**

---

**District Offices**

**Westinghouse Bldg.**  
**NEW YORK**

**Peoples Gas Bldg.**  
**CHICAGO**

**Railway Exchange Bldg.**  
**ST. LOUIS**

**Matson Bldg.**  
**SAN FRANCISCO**

**Dominion Square Bldg.**  
**MONTREAL**

**Represented by the INTERNATIONAL GENERAL ELECTRIC CO., in South Africa  
and Argentina**

**By McKENZIE & HOLLAND PTY. LTD. in Australasia**