

The Federal Railway Signal  
Company

1905

WORKS:  
TROY, N. Y.

SIXTY WALL STREET  
NEW YORK

MONADNOCK BLOCK  
CHICAGO

CATALOGUE

OF,

The Federal Railway Signal Co.

1905

R

625.1650294

F317c

1905

830101

**THE LIBRARY OF  
HENRY J. GRUND**

WORKS:  
TROY, N. Y.

SIXTY WALL STREET  
NEW YORK

MONADNOCK BLOCK  
CHICAGO



## PREFACE

One of the first needs of a Signal Company is a Catalogue, and we take pleasure in presenting this for your use and consideration.

In compiling this Catalogue we have included the devices generally used in mechanical interlocking plants. It is sent forward as a temporary Catalogue, to be followed in the near future by one more complete.

This Company is in a position to supply all parts of mechanical interlocking shown in any book of reference; or, which may be obsolete. We are also prepared to submit estimates for installation of interlocking, signaling and safety appliances, including mechanical and power interlocking plants; and manually controlled, or automatic, block signaling.

THE FEDERAL RAILWAY SIGNAL COMPANY





### Style "A" (Standard) Interlocking Machine

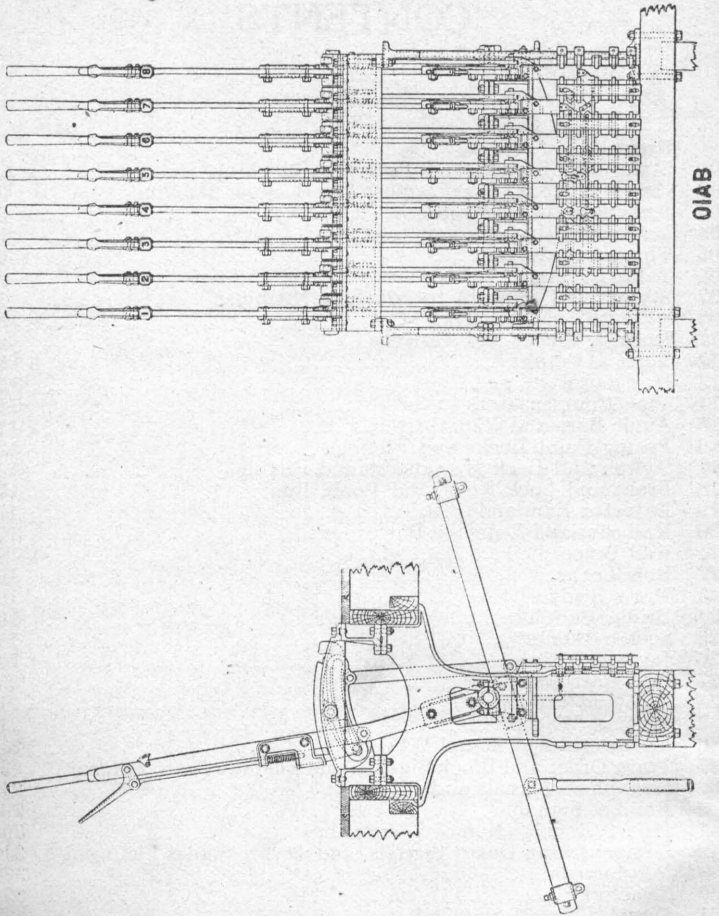

ORDER No.	01. STYLE "A" (STANDARD) INTER-LOCKING MACHINE	LIST PRICE	WEIGHT	
			LBS	OZS
01 AA	4 Lever Machine complete, per Lever . . . . .	28 80		
	Spare spaces . . . . .	11 40		
01 AB	8 Lever Machine complete, per Lever . . . . .	28 80		
	Spare spaces . . . . .	11 40		
01 AD	12 Lever Machine complete, per Lever . . . . .	28 80		
	Spare spaces . . . . .	11 40		
01 AE	16 Lever Machine complete, per Lever . . . . .	30 00		
	Spare spaces . . . . .	11 40		
01 AF	20 Lever Machine complete, per Lever . . . . .	30 00		
	Spare spaces . . . . .	11 40		
01 AG	24 Lever Machine complete, per Lever . . . . .	30 00		
	Spare spaces . . . . .	11 40		
01 AH	28 Lever Machine complete, per Lever . . . . .	31 20		
	Spare spaces . . . . .	11 40		
01 AJ	32 Lever Machine complete, per Lever . . . . .	31 20		
	Spare spaces . . . . .	11 40		
01 AK	36 Lever Machine complete, per Lever . . . . .	31 20		
	Spare spaces . . . . .	11 40		
01 AL	40 Lever Machine complete, per Lever . . . . .	31 20		
	Spare spaces . . . . .	11 40		
01 AM	44 Lever Machine complete, per Lever . . . . .	31 20		
	Spare spaces . . . . .	11 40		
01 AN	48 Lever Machine complete, per Lever . . . . .	31 20		
	Spare spaces . . . . .	11 40		
01 AP	52 Lever Machine complete, per Lever . . . . .	32 40		
	Spare spaces . . . . .	12 60		



## THE FEDERAL RAILWAY SIGNAL COMPANY

ORDER NO.	01. STYLE "A" (STANDARD) INTER- LOCKING MACHINE— Cont.	LIST PRICE	WEIGHT	
			LBS	OZS
01 AR	56 Lever Machine complete, per Lever .....	32 40		
	Spare spaces .....	12 60		
01 AS	60 Lever Machine complete, per Lever .....	32 40		
	Spare spaces .....	12 60		
01 AT	64 Lever Machine complete, per Lever .....	32 40		
	Spare spaces .....	12 60		
01 AV	68 Lever Machine complete, per Lever .....	32 40		
	Spare spaces .....	12 60		
01 AW	72 Lever Machine complete, per Lever .....	32 40		
	Spare spaces .....	12 60		
01 AX	76 Lever Machine complete, per Lever .....	33 60		
	Spare spaces .....	13 20		
01 AY	80 Lever Machine complete, per Lever .....	33 60		
	Spare spaces .....	13 20		
01 AZ	84 Lever Machine complete, per Lever .....	33 60		
	Spare spaces .....	13 20		
01 BA	88 Lever Machine complete, per Lever .....	33 60		
	Spare spaces .....	13 20		
01 BB	92 Lever Machine complete, per Lever .....	33 60		
	Spare spaces .....	13 20		
01 BD	96 Lever Machine complete, per Lever .....	33 60		
	Spare spaces .....	13 20		
01 BE	100 Lever Machine com- plete, per Lever .....	33 60		
	Spare spaces .....	13 20		





### Style "A" (Standard) Interlocking Machine Fittings

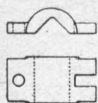

**OIBG**

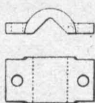

**OIBY**

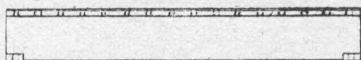

**OIDA**



**OIDE**

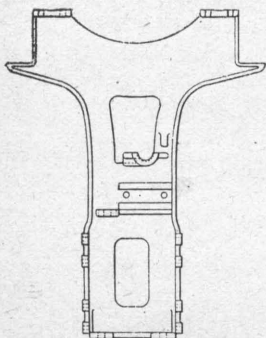

**OIBF**

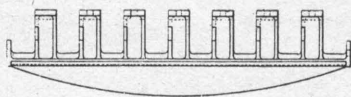

**OIBV**



**OIDM**

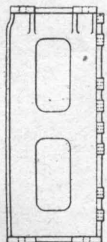

**OIBK**

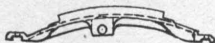

**OILJ**

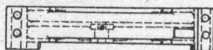

**OIDJ**

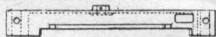

**OIDF**

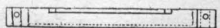

ORDER No.	01. STYLE "A" (STANDARD) INTER- LOCKING MACHINE FITTINGS—Cont.	LIST PRICE	WEIGHT	
			LBS	OZS
01 BF	Machine Leg.....	10 71		
01 BG	Machine Leg Bearing Cap	10		
01 BH	1— $\frac{5}{8}$ " x $2\frac{1}{4}$ " Bolt with 2 spl. hex. Nuts to each Ma- chine Leg Bearing Cap.	05		
01 BJ	4 Space Extension Leg..	6 80		
01 BK	9 " " " " ..	8 50		
01 BL	14 " " " " ..	11 90		
01 BM	19 " " " " ..	15 30		
01 BN	24 " " " " ..	18 70		
01 BP	29 " " " " ..	22 10		
01 BR	4— $\frac{5}{8}$ " x $2\frac{1}{2}$ " Bolts and Nuts, to each Extension Leg, each.....	05		
01 BS	4— $\frac{5}{8}$ " Washers to each Ex- tension Leg..... each	01		
01 BT	4 Lever Bottom Girder...	3 91		
01 BV	8 Lever Bottom Girder...	7 65		
01 BR	2— $\frac{5}{8}$ " x $2\frac{1}{2}$ " Bolts and Nuts to each Bottom Girder for fixing to End Leg each.....	05		
01 BW	2— $\frac{5}{8}$ " Lock Washers, to each Bottom Girder for fixing to End Leg..each	01		
01 BX	1— $\frac{5}{8}$ " x $3\frac{1}{4}$ " Bolt and Nut to each Bottom Girder for fixing to Intermedi- ate Leg..... each	04		
01 BW	1— $\frac{5}{8}$ " Lock Washer to each Bottom Girder for fix- ing to Intermediate Leg	01		
01 BY	Bottom Girder Bearing Cap.....	10		
01 BH	2— $\frac{5}{8}$ " x $2\frac{1}{4}$ " Bolts with 2 spl. hex. Nuts each for Cap, each.....	05		
01 BZ	4 Lever Front Girder....	3 31		
01 DA	8 Lever Front Girder....	4 08		
01 BR	4— $\frac{5}{8}$ " x $2\frac{1}{2}$ " Bolts and Nuts to each Front Girder, ea.	05		



ORDER No.	01. STYLE "A" (STANDARD) INTER- LOCKING MACHINE FITTINGS.—Cont.	LIST PRICE	WEIGHT	
			LBS	OZS
01 BS	4— $\frac{5}{8}$ " Washers to each Front Girder.....each	01		
01 DB	2— $\frac{3}{8}$ " x $1\frac{1}{8}$ " Taper Dowel Pins to each Front Gir- der .....	03		
01 DD	4 Lever Back Girder...	4 38		
01 DE	8 Lever Back Girder...	8 28		
01 BR	4— $\frac{5}{8}$ " x $2\frac{1}{2}$ " Bolts and Nuts to each Back Girder, ea	05		
01 BS	4— $\frac{5}{8}$ " Washers to each Back Girder.....each	01		
01 DB	2— $\frac{3}{8}$ " x $1\frac{1}{8}$ " Taper Dowel Pins to each Back Gir- der .....	03		
01 DF	Left-hand End Segment..	2 19		
01 DG	Left - hand Intermediate Segment (Old style, see 01 LJ).....	1 33		
01 DH	Right-hand Intermediate Segment (Old style, see 01 LJ) .....	2 21		
01 DJ	Right-hand End Segment	2 34		
01 DK	2— $\frac{5}{8}$ " x $1\frac{1}{2}$ " Tap. Bolts to each Segment....each	03		
01 DL	4 Lever Tappet-Stop Gir- ders. Used only when locking is placed at the back of Machine.....	2 25		
01 DM	8 Lever Tappet-Stop Gir- der, used only when locking is placed at the back of Machine.....	4 00		
01 BR	2— $\frac{5}{8}$ " x $2\frac{1}{2}$ " Bolts and Nuts to each Tappet-Stop Girder for fixing to End Leg.....each	05		
01 BW	2— $\frac{5}{8}$ " Lock Washers, to each Tappet-Stop Gir- der for fixing to end Leg.....each	01		
01 BX	1— $\frac{5}{8}$ " x $3\frac{1}{4}$ " Bolt and Nut, to each Tappet-Stop Gir- der for fixing to Inter- mediate Leg.....	04		
01 BW	1— $\frac{5}{8}$ " Lock Washer, to each Tappet-Stop Gir- der for fixing to Inter- mediate Leg.....	01		





ORDER NO.	01. STYLE "A" (STANDARD) INTER- LOCKING MACHINE FITTINGS.—Cont.	LIST PRICE	WEIGHT	
			LBS	OZS
01 DN	Lever complete including Lever, Lever Number, Latch Handle and pins, Latch Rod, Latch Spring, Latch Shoe, Latch Block, Lever Shoe and Center Pin, Rocker, Rocker Pin and Roller, and Tappet connecting Link and Pin—No Tap- pet nor Lever Tail. These must be ordered separately, stating length of Tappet and stroke of Lever Tail, State number required for Lever when order- ing.....	16 00		
01 DP	Lever .....	4 54		
01 DR	Rocker Guide .....	06		
01 DS	2— $\frac{3}{8}$ " x $1\frac{3}{8}$ " Rivets each .....	01		
01 DT	Lever Number .....	13		
01 DV	$\frac{1}{4}$ " x $1\frac{1}{2}$ " Bolt and Nut, each .....	01		
01 DW	Latch Handle .....	52		
01 DX	2— $\frac{5}{8}$ " x $1\frac{7}{8}$ " Pins, each .....	06		
01 DY	2— $\frac{3}{8}$ " Washers, each .....	01		
01 DZ	2— $\frac{3}{8}$ " x 1" Split Cotters, each .....	01		
01 EA	Latch Rod .....	55		
01 EB	" Spring .....	10		
01 ED	" Shoe .....	61		
01 EE	2— $\frac{5}{8}$ " x $1\frac{3}{4}$ " Cap Screws each .....	03		
01 EF	Latch Block .....	2 46		
01 EG	Roller .....	15		
01 EH	1— $\frac{1}{8}$ " x $1\frac{1}{4}$ " Split Cotter .....	01		
01 EJ	Lever Shoe .....	1 28		
01 EK	2— $\frac{3}{4}$ " x $2\frac{1}{4}$ " Bolts with esk hds. & hex. nuts, each .....	08		
01 EL	1— $\frac{1}{2}$ " x $1\frac{3}{8}$ " Dowel Pin .....	01		
01 EM	$1\frac{1}{2}$ " x 5" Centre Pin for Intermediate Lever .....	21		
01 EN	$1\frac{1}{2}$ " x $6\frac{1}{4}$ " Centre Pin for End Lever .....	24		
01 EP	Rocker .....	1 94		
01 ER	Rocker Pin for Intermed- iate Segment .....	08		

ORDER NO.	01. STYLE "A" (STANDARD) INTER- LOCKING MACHINE FITTINGS.—Cont.	LIST PRICE	WEIGHT	
			LBS	OZS
01 ES	Rocker Pin for End Segment .....	08		
01 ET	1—14-24 x 1" Filister hd. Screw to each Rocker Pin .....	02		
01 EV	Tappet Connecting Link for Front of Machine ..	61		
01 EW	Tappet Connecting Link for back of Machine...	75		
01 EX	Connecting Link Pin..	10		
01 EY	1— $\frac{1}{8}$ " x $\frac{1}{4}$ " Split Cot- ter .....	01		





### Style "A" (Standard) Interlocking Machine Fittings

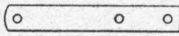

DIEZ

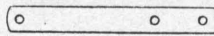

DIFA

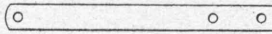

DIFB



53AX

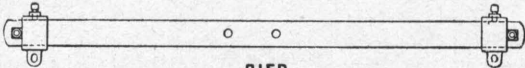

DIFD

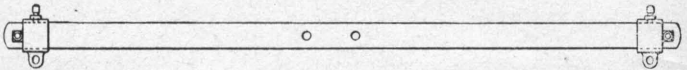

DIFE

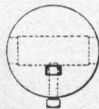

38HA

ORDER NO.	01. STYLE "A" (STANDARD) INTER-LOCKING MACHINE FITTINGS.—Cont.	LIST PRICE		WEIGHT	
				LBS	OZS
01 EZ	Front Lever Tail 7" Stroke	66			
01 FA	" " " 8" "	71			
01 FB	" " " 12" "	90			
01 FD	Front and Back Lever Tail 12" Stroke	1 02			
01 FE	Front and Back Lever Tail 16" Stroke	1 15			
01 EK	2— $\frac{3}{4}$ " x $2\frac{1}{4}$ " Bolts and csk. hds. & hex. nuts to each. Lever Tail..... each.	08			
53 AX	Adjustable Connector	35			
53 AS	$\frac{7}{8}$ " Shackle and Pin	10			
38 HA	56 lb. Balance weight.	2 80			

# Style "A" (Standard) Interlocking Machine Fittings

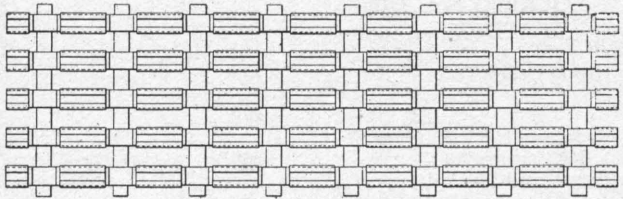

**OIFH**

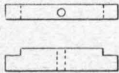

**OIFM**

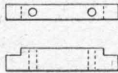

**OIFR**

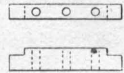

**OIFS**

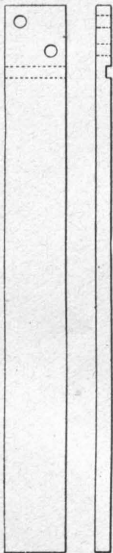

**OIGA**



**OIFT**

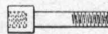

**OIFP**

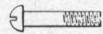

**OIFN**

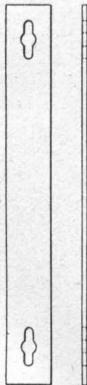

**OIFV**



**OIFZ**

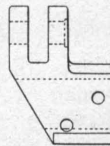

**OIFX**



**OIFY**



**OIFW**



**OIFY**

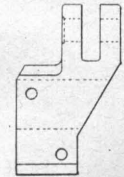

**OIFY**

ORDER NO.	01. STYLE "A" (STANDARD) INTER-LOCKING MACHINE FITTINGS.—Cont.	LIST PRICE		WEIGHT	
				LBS	OZs
01 FF	4 Lever 4 Space Locking Plate .....	-			
01 FH	8 Lever 4 Space Locking Plate .....	7	00		
01 FK	4— $\frac{3}{8}$ " x $1\frac{1}{8}$ " Cap Screws to each Locking Plate, each .....	14	00		
01 FL	4— $\frac{3}{8}$ " Special Washers to each Locking Plate, each .....		06		
01 DB	4— $\frac{3}{8}$ " $1\frac{1}{8}$ " Taper Dowel Pins to each Locking Plate .....		01		
01 FM	No. 1 Front Locking Guide $3\frac{11}{16}$ " long .....		03		
01 FN	1—14-24x $1\frac{1}{8}$ " rd. hd. Machine Screw to each No. 1 Front Locking Guide .....		10		
01 FP	1 Spl. screwed and tapped stud to each No. 1 Front Locking Guide .....		01		
01 FR	No. 2 Front Locking Guide $3\frac{11}{16}$ " long .....		05		
01 FN	2—14-24 x $1\frac{1}{8}$ " rd. hd. Machine Screws to each No. 2 Front Locking Guide .....		10		
01 FS	No. 3 Front Locking Guide $3\frac{11}{16}$ " long .....		01		
01 FN	2—14-24 x $1\frac{1}{8}$ " rd. hd. Machine Screws to each No. 3 Front Locking Guide .....		10		
01 FP	1 Spl. screwed and tapped stud to each No. 3 Front Locking Guide .....		01		
01 FT	No. 4 Front Locking End Guide $1\frac{3}{4}$ " long .....		05		
01 FN	1—14-24 x $1\frac{1}{8}$ " rd. hd. Machine Screw to each No. 4 Front Locking Guide .....		10		
01 FV	Locking Plate Strips $\frac{1}{8}$ " x $1\frac{1}{2}$ " x $12\frac{1}{2}$ " .....		01		
01 FW	2—14-24 x $\frac{3}{8}$ " rd. hd. Machine Screws to each Locking Plate Strip, each .....		12		
01 FX	Left-hand Tappet Jaw .....		01		
01 FY	Right-hand Tappet Jaw .....		71		
01 FZ	Tappet Jaw Pin .....		71		
			12		



ORDER No.	01. STYLE "A" (STANDARD) INTER- LOCKING MACHINE FITTINGS—Cont.	LIST PRICE	WEIGHT	
			LBS	OZS
01 EY	$\frac{1}{8}$ " x $1\frac{1}{4}$ " Split Cotter.....	01		
01 GA	Tappet for 4 Space Locking Plate .....	81		
01 GB	Tappet for 9 Space Locking Plate .....	1 40		
01 GD	Tappet for 14 Space Lock- ing Plate .....	1 70		
01 GE	Tappet for 19 Space Lock- ing Plate .....	2 00		
01 GF	Tappet for 24 Space Lock- ing Plate .....	2 30		
01 GG	Tappet for 29 Space Lock- ing Plate .....	3 00		
01 GH	Tappet for 34 Space Lock- ing Plate .....	3 75		
01 GJ	2— $\frac{3}{8}$ "x $1\frac{1}{8}$ " Cap Screws, each	03		

*[Faint, illegible text and markings, possibly bleed-through from the reverse side of the page.]*

## Style "A" (Standard) Interlocking Machine Fittings.

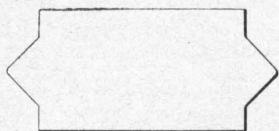
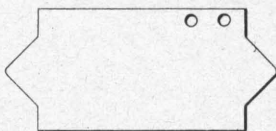
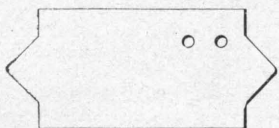
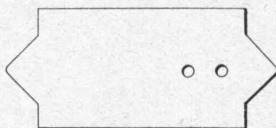
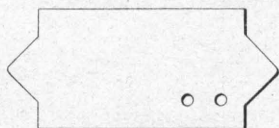
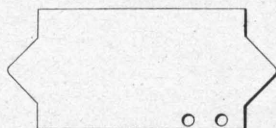
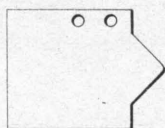
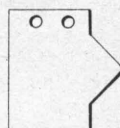
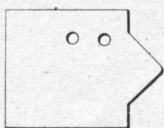
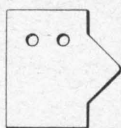
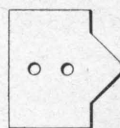
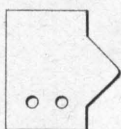
**OI GK****OI GL****OI GM****OI GN****OI GP****OI GR****OI GS****OI GT****OI GZ****OI HA****OI GV****OI GW****OI HB****OI HD****OI GX****OI GY****OI HE****OI HF**

ORDER No.	01. STYLE "A" (STANDARD) INTER- LOCKING MACHINE FITTINGS.—Cont.				LIST PRICE	WEIGHT	
						LBS	OZS
01 GK	No. 1	Front	Locking	Dog	48		
01 GL	" 1	"	"	" A	66		
01 GM	" 1	"	"	" B	66		
01 GN	" 1	"	"	" C	66		
01 GP	" 1	"	"	" D	66		
01 GR	" 1	"	"	" E	66		
01 GS	" 2	"	"	"	20		
01 GT	" 2	"	"	" A	38		
01 GV	" 2	"	"	" B	38		
01 GW	" 2	"	"	" C	38		
01 GX	" 2	"	"	" D	38		
01 GY	" 2	"	"	" E	38		
01 GZ	" 3	"	"	"	25		
01 HA	" 3	"	"	" A	42		
01 HB	" 3	"	"	" B	42		
01 HD	" 3	"	"	" C	42		
01 HE	" 3	"	"	" D	42		
01 HF	" 3	"	"	" E	42		

## Style "A" (Standard) Interlocking Machine Fittings

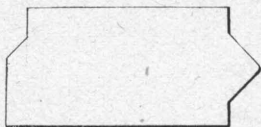
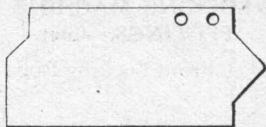
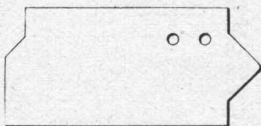
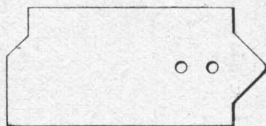
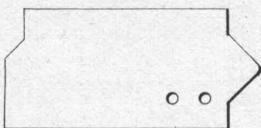
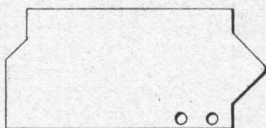
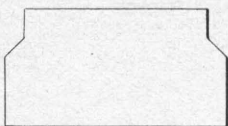
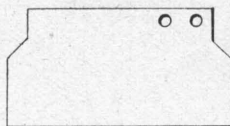
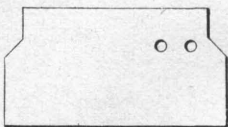
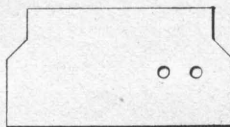
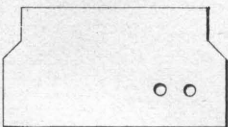
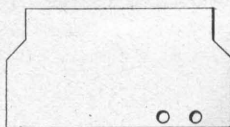
**OI HO****OI HH****OI HJ****OI HK****OI HL****OI HM****OI HN****OI HP****OI HR****OI HS****OI HT****OI HV**



ORDER No.	01 STYLE "A" (STANDARD) INTER-LOCKING MACHINE FITTINGS.—Cont.					LIST. PRICE	WEIGHT	
							LBS	OZS
01 HG	No. 4	Front	Locking	Dog	.....	42	.....	.....
01 HH	" 4	"	"	"	A	64	.....	.....
01 HJ	" 4	"	"	"	B	64	.....	.....
01 HK	" 4	"	"	"	C	64	.....	.....
01 HL	" 4	"	"	"	D	64	.....	.....
01 HM	" 4	"	"	"	E	64	.....	.....
01 HN	" 5	"	"	"	..	34	.....	.....
01 HP	" 5	"	"	"	A	51	.....	.....
01 HR	" 5	"	"	"	B	51	.....	.....
01 HS	" 5	"	"	"	C	51	.....	.....
01 HT	" 5	"	"	"	D	51	.....	.....
01 HV	" 5	"	"	"	E	51	.....	.....

### Style "A" (Standard) Interlocking Machine Fittings.



OIHW

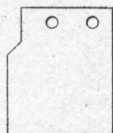

OIHX

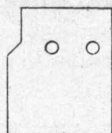

OIHY

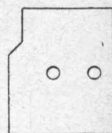

OIHZ

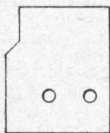

OIJA

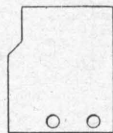

OIJB

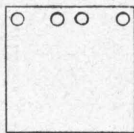

OIJE

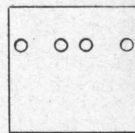

OIJF

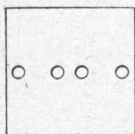

OIJG

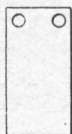

OIJH



OIJJ

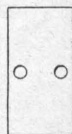

OIJK

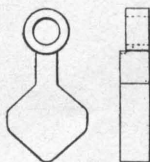

OIJL



OIJM



OIJD



OIJN



OIJW



OIJP



OIJR



OIJS



OIJT



OIJV

ORDER No.	01. STYLE "A" (STANDARD) INTER- LOCKING MACHINE FITTINGS.—Cont.	LIST PRICE	WEIGHT	
			LBS	OZS
01 HW	No. 6 Front Locking Dog	30		
01 HX	" " " " " A	47		
01 HY	" " " " " B	47		
01 HZ	" " " " " C	47		
01 JA	" " " " " D	47		
01 JB	" " " " " E	47		
01 JD	2—10-32x $\frac{13}{8}$ " Spl. flat-head Machine Screws to each Front Locking Dog. each	02		
01 JE	No. 7 Front Coupling Dog A	47		
01 JF	" " " " " B	47		
01 JG	" " " " " C	47		
01 JD	4—10-32x $\frac{13}{8}$ " Spl. flat-head Machine Screws to each Coupling Dog..... each	02		
01 JH	No. 7 Front Carrier Dog D	30		
01 JJ	" " " " " E	30		
01 JK	" " " " " F	30		
01 JD	2—10-32 x $\frac{13}{8}$ " Spl. flat-head Machine Screws to each Carrier Dog..... each	02		
01 JL	No. 8 Special Swing Dog	51		
01 JM	1 Special Stud to each Swing Dog.....	06		
01 JN	No. 9 Tappet piece A	68		
01 JP	" " " " B	68		
01 JR	" 10 " " A	38		
01 JS	" " " " B	38		
01 JT	" 11 " " "	14		
01 JV	" 12 " " "	60		
01 JW	2—14-24 x $\frac{3}{4}$ " Filister hd. Machine Screws to each Tappet piece..... each	02		

## Style "A" (Standard) Interlocking Machine Fittings.

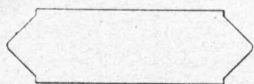

OI JX

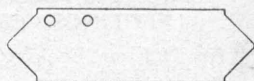

OI JY

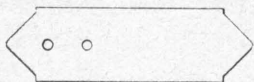

OI JZ

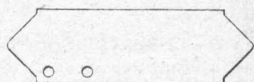

OI KA

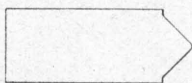

OI KB

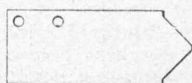

OI KD

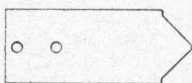

OI KE



OI KX

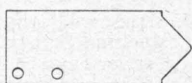

OI KF

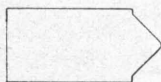

OI KG



OI KH

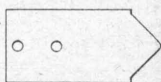

OI KJ

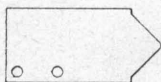

OI KK



OI KL



OI KM



OI KN

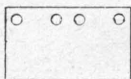

OI KP

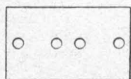

OI KR



OI KS



OI KT



OI KV



OI KW

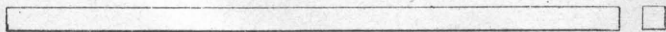

OI KY

ORDER No.	01. STYLE "A" (STANDARD) INTER- LOCKING MACHINE FITTING.—Cont.	LIST PRICE	WEIGHT	
			LBS	OZS
01 JX	No. 13 Back Locking Dog	28		
01 JY	" " " " " A	46		
01 JZ	" " " " " B	46		
01 KA	" " " " " C	46		
01 KB	No. 14 " " " " "	11		
01 KD	" " " " " A	29		
01 KE	" " " " " B	29		
01 KF	" " " " " C	29		
01 KG	No. 15 " " " " "	15		
01 KH	" " " " " A	34		
01 KJ	" " " " " B	34		
01 KK	" " " " " C	34		
01 KL	No. 16 " " " " "	33		
01 KM	" " " " " B	33		
01 KN	" " " " " C	33		
01 KP	No. 17 " Coupling " A	48		
01 KR	" " " " " B	48		
01 KS	No. 18 " Carrier " A	25		
01 KT	" " " " " B	25		
01 KV	No. 19 " " " " " A	17		
01 KW	" " " " " B	17		
01 KX	2—10 - 32 x $\frac{15}{16}$ " Special flat head Machine Screws to each Back Locking Dog, Coupler and Carrier. each	02		
01 KY	Steel Bar $\frac{3}{8}$ " x $\frac{3}{8}$ " for connecting Locking Dogs	08		
01 LA	Right-hand Intermediate Segment for Electric Lock (Old Style, see 01-LK) . . . .	2 50		
01 LB	Left-hand Intermediate Segment for Electric Lock (Old Style, see 01-LK) . . . .	1 50		
01 LJ	Intermediate Segment in one piece. Takes the place of 01-DG and 01-DH. . . . .	3 00		
01 LK	Intermediate Segment in one piece for Electric Lock. Takes the place of 01-LA and 01-LB. . . . .	3 50		



## Style "B" (Saxby &amp; Farmer) Interlocking Machine

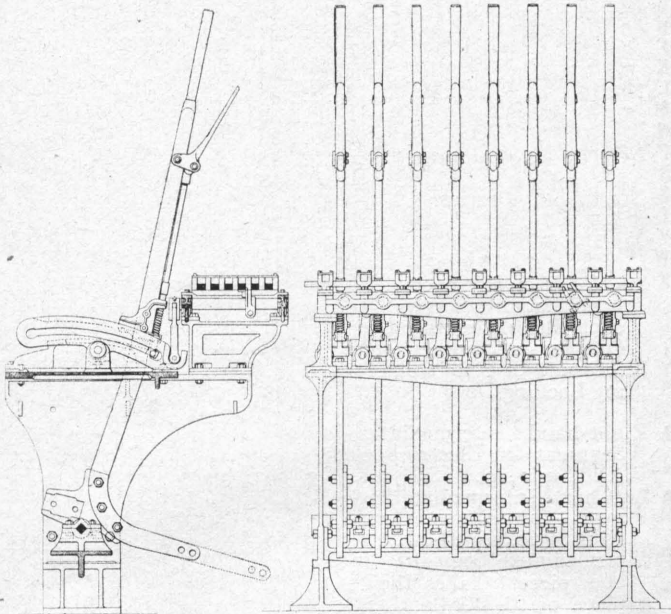

02AB

ORDER NO.	02. STYLE "B" (SAXBY & FARMER) INTERLOCKING MACHINE.	LIST PRICE		WEIGHT	
				LBS	OZS
02 AA	4 Lever Machine complete, per lever.....	28	80		
	Spare spaces.....	11	40		
02 AB	8 Lever Machine complete, per lever.....	28	80		
	Spare spaces.....	11	40		
02 AD	12 Lever Machine complete, per lever.....	28	80		
	Spare spaces.....	11	40		
02 AE	16 Lever Machine complete, per lever.....	30	00		
	Spare spaces.....	11	40		
02 AF	20 Lever Machine complete, per lever.....	30	00		
	Spare spaces.....	11	40		
02 AG	24 Lever Machine complete, per lever.....	30	00		
	Spare spaces.....	11	40		
02 AH	28 Lever Machine complete, per lever.....	31	20		
	Spare spaces.....	11	40		
02 AJ	32 Lever Machine complete, per lever.....	31	20		
	Spare spaces.....	11	40		
02 AK	36 Lever Machine complete, per lever.....	31	20		
	Spare spaces.....	11	40		
02 AL	40 Lever Machine complete, per lever.....	31	20		
	Spare spaces.....	11	40		
02 AM	44 Lever Machine complete, per lever.....	31	20		
	Spare spaces.....	11	40		
02 AN	48 Lever Machine complete, per lever.....	31	20		
	Spare spaces.....	11	40		
02 AP	52 Lever Machine complete, per lever.....	32	40		
	Spare spaces.....	12	60		
02 AR	56 Lever Machine complete, per lever.....	32	40		
	Spare spaces.....	12	60		
02 AS	60 Lever Machine complete, per lever.....	32	40		
	Spare spaces.....	12	60		
02 AT	64 Lever Machine complete, per lever.....	32	40		
	Spare spaces.....	12	60		

ORDER NO.	02. STYLE "B" (SAXBY & FARMER) INTERLOCKING MA- CHINE.—Cont.	LIST PRICE		WEIGHT	
				LBS	OZS
02 AV	68 Lever Machine complete, per lever.....	32	40		
	Spare spaces.....	12	60		
02 AW	72 Lever Machine complete, per lever.....	32	40		
	Spare spaces.....	12	60		
02 AX	76 Lever Machine complete, per lever.....	33	60		
	Spare spaces.....	13	20		
02 AY	80 Lever Machine complete, per lever.....	33	60		
	Spare spaces.....	13	20		
02 AZ	84 Lever Machine complete, per lever.....	33	60		
	Spare spaces.....	13	20		
02 BA	88 Lever Machine complete, per lever.....	33	60		
	Spare spaces.....	13	20		
02 BB	92 Lever Machine complete, per lever.....	33	60		
	Spare spaces.....	13	20		
02 BD	96 Lever Machine complete, per lever.....	33	60		
	Spare spaces.....	13	20		
02 BE	100 Lever Machine complete, per lever.....	33	60		
	Spare spaces.....	13	20		

NOTE—Special Interlocking Machine Style "B" for horizontal Lead-out at same prices as ordinary machine.



## Style "B" (Saxby &amp; Farmer) Interlocking Machine Fittings.

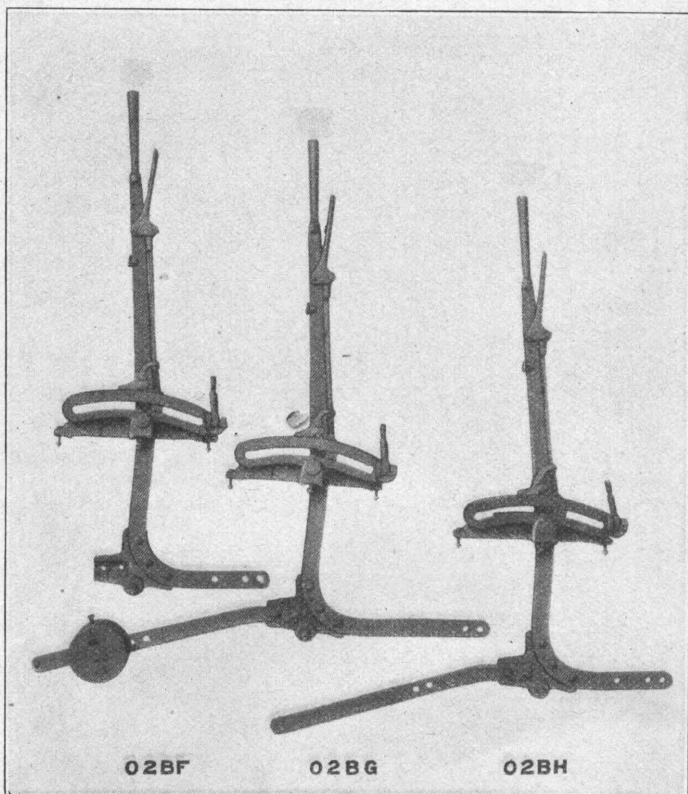

ORDER No.	02. STYLE "B" (SAXBY & FARMER) INTERLOCKING MA- CHINE FITTINGS.	LIST PRICE	WEIGHT	
			LBS	OZS
02 BF	Switch Lever complete.....	15 96		
02 BG	Distant Signal Lever com- plete with counterweight..	17 42		
02 BH	Home Signal Lever com- plete for wire connections.	16 28		
02 BJ	Home Signal Lever com- plete for pipe connections with counterweight.....	19 45		





ORDER No.	02. STYLE "B" (SAXBY & FARMER) IN- TERLOCKING MACHINE FITTINGS.—Cqnt.	LIST PRICE		WEIGHT	
				LBS	OZS
02 BK	Machine Leg . . . . .	10	92		
02 BL	4 Lever Bottom Girder . . . . .	4	40		
02 BM	8 Lever Bottom Girder . . . . .	7	92		
02 BN	Cap for Bottom Girder . . . . .		07		
02 BP	Lever Shoe . . . . .	1	20		
02 BR	4 Lever Top Plate . . . . .	6	59		
02 BS	8 Lever Top Plate . . . . .	11	57		
02 BT	Left-hand End Top Plate . . . . .		55		
02 BV	Right-hand End Top Plate . . . . .		55		
02 BW	4-way Bearing for Rails . . . . .	1	74		
02 BX	6-way " " " . . . . .	1	98		
02 BY	8-way " " " . . . . .	2	27		
02 BZ	10-way " " " . . . . .	2	48		
02 DA	12-way " " " . . . . .	2	71		
02 DB	14-way " " " . . . . .	2	76		
02 DD	16-way " " " . . . . .	3	24		
02 DE	18-way " " " . . . . .	3	32		
02 DF	20-way " " " . . . . .	3	73		
02 DG	24-way " " " . . . . .	5	05		
02 DH	28-way " " " . . . . .	5	54		
02 DJ	30-way " " " . . . . .	6	11		
02 DK	32-way " " " . . . . .	6	41		
02 DL	36-way " " " . . . . .	7	06		
02 DM	40-way " " " . . . . .	8	14		
02 DN	4 Lever Front Rail . . . . .	1	70		
02 DP	4 Lever Front Rail Cap . . . . .	1	14		
02 DR	8 Lever Front Rail . . . . .	3	28		
02 DS	8 " " " Cap . . . . .	2	44		
02 DT	4 " Intermediate Rail . . . . .	2	05		
02 DV	4 Lever Intermediate Rail Cap . . . . .	1	44		
02 DW	8 Lever Intermediate Rail . . . . .	3	78		
02 DX	8 Lever Intermediate Rail Cap . . . . .	2	74		
02 DY	4 Lever Back Rail . . . . .	2	27		
02 DZ	8 Lever Back Rail . . . . .	3	89		
02 EA	Left-hand End Block . . . . .		28		
02 EB	Intermediate End Block . . . . .		32		
02 ED	Right-hand End Block . . . . .		28		
02 EE	4-way Locking Bracket . . . . .	1	22		
02 EF	4-way " " Cap . . . . .		24		
02 EG	6-way " " . . . . .	1	42		
02 EH	6-way " " Cap . . . . .		25		
02 EJ	8-way " " . . . . .	1	60		
02 EK	8-way " " Cap . . . . .		28		
02 EL	10-way " " . . . . .	1	80		
02 EM	10-way " " Cap . . . . .		32		
02 EN	12-way " " . . . . .	1	84		

ORDER No.	02. STYLE "B" (SAXBY & FARMER) IN- TERLOCKING MACHINE FITTING.—Cont.	LIST PRICE		WEIGHT	
				LBS	OZS
02 EP	12-way Locking Bracket Cap	35			
02 ER	14-way " " " "	2 05			
02 ES	14-way " " Cap	36			
02 ET	15-way " " " "	2 11			
02 EV	15-way " " Cap	38			
02 EW	16-way " " " "	2 20			
02 EX	16-way " " Cap	41			
02 EY	18-way " " " "	2 41			
02 EZ	18-way " " Cap	43			
02 FA	20-way " " " "	2 62			
02 FB	20-way " " Cap	46			
02 FD	Quadrant	2 68			
02 FE	Rocker	2 44			
02 FF	Lever	4 57			
02 FG	Latch Shoe	54			
02 FH	Latch Rod	1 03			
02 FJ	Universal Link	13			
02 FK	Latch Handle	60			
02 FL	Latch Spring	19			
02 FM	Latch Rod Thimble	17			
02 FN	4-way Locking Shaft	1 25			
02 FP	6-way " " " "	1 38			
02 FR	8-way " " " "	1 51			
02 FS	10-way " " " "	1 64			
02 FT	12-way " " " "	1 76			
02 FV	14-way " " " "	1 87			
02 FW	16-way " " " "	2 03			
02 FX	18-way " " " "	2 05			
02 FY	20-way " " " "	2 14			
02 FZ	24-way " " " "	2 84			
02 GA	28-way " " " "	3 36			
02 GB	30-way " " " "	3 48			
02 GD	32-way Locking Shaft	3 60			
02 GE	36-way Locking Shaft	3 86			
02 GF	40-way Locking Shaft	4 14			
02 GG	Crank for Locking Shaft	13			
02 GH	Driver for Locking Bar	22			
02 GJ	Filling Block for Driver	08			
02 CK	Short Tail Lever	66			
02 GL	Long Tail Lever	92			
38 GY	40 lb. Weight complete, with Bolt for Tail Lever	2 00			
38 HA	56 lb. Weight complete, with Bolt for Tail Lever	2 80			
53 AX	Adjustable Connector	35			



## Style "B" (Saxby &amp; Farmer) Interlocking Machine Fittings.

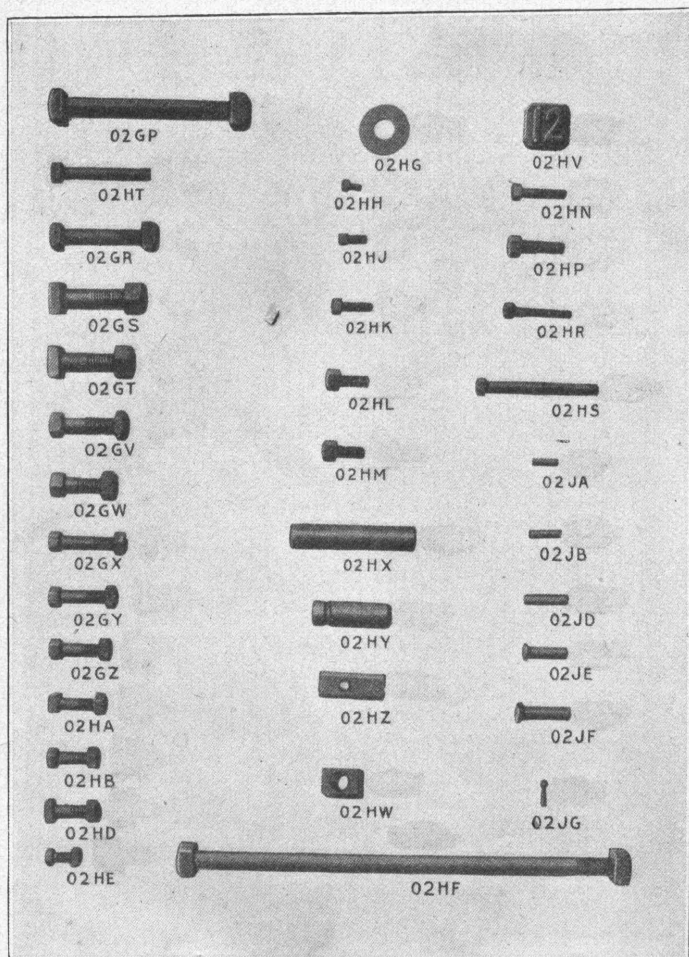

ORDER NO.	02. STYLE "B" (SAXBY & FARMER) INTERLOCKING MACHINE FITTINGS.—Cont.	LIST PRICE	WEIGHT	
			LBS	OZ
02 GP	$\frac{3}{4}$ " x 7" Bolt and Nut for fastening leg to timber framing.....	13		
02 GR	$\frac{5}{8}$ " x 4 $\frac{1}{2}$ " Bolt and Nut for 40 and 56 lb. weights.....	07		
02 GS	$\frac{3}{4}$ " x 2 $\frac{1}{2}$ " Bolt and Nut for fastening Bottom Girder to Intermediate Leg.....	09		
02 GT	$\frac{3}{4}$ " x 2 $\frac{1}{4}$ " Bolt and Nut for fastening Bottom Girder to End Leg.....	09		
02 GV	$\frac{5}{8}$ " x 2 $\frac{1}{4}$ " Bolt and Nut for Clamping Driver to Locking Shaft.....	07		
02 GW	$\frac{5}{8}$ " x 2" Bolt and Nut for fastening Lever and Tail Lever to Lever Shoe.....	07		
02 GX	$\frac{1}{2}$ " x 2 $\frac{1}{2}$ " Bolt and Nut for fastening middle and front of Quadrant to Top Plate.....	04		
02 GY	$\frac{1}{2}$ " x 2 $\frac{1}{4}$ " Bolt and Nut for fastening Crank to Locking Shaft.....	04		
02 GZ	$\frac{1}{2}$ " x 1 $\frac{7}{8}$ " Bolt and Nut for fastening Locking Bearing to Leg and back of Quadrant to Top Plate.....	04		
02 HA	$\frac{1}{2}$ " x 1 $\frac{3}{4}$ " Bolt and Nut for fastening Cap to Bottom Girder.....	04		
02 HB	$\frac{1}{2}$ " x 1 $\frac{5}{8}$ " Bolt and Nut, full head, for fastening Top Plate and End Top Plate to Leg.....	04		
02 HD	$\frac{1}{2}$ " x 1 $\frac{3}{8}$ " Bolt and Nut, T head, for fastening Top Plate and End Top Plate to Leg.....	04		
02 HE	$\frac{3}{8}$ " x 1" Bolt and Nut, Hexagon-Head and Nut, for End of Tail Lever.....	03		
02 HF	$\frac{3}{4}$ " x 17" Bolt and Nut for fastening Leg to Timber Framing.....	22		
02 HG	$\frac{3}{4}$ " Washer for 02 GP.....	01		



ORDER No.	02. STYLE "A" (SAXBY & FARMER) INTERLOCKING MACHINE FITTINGS.—Cont.	LIST PRICE	WEIGHT	
			LBS	OZS
02 HH	$\frac{1}{4}$ " x $\frac{1}{2}$ " Cap Screw for fastening Cap to Locking Bracket.....	04		
02 HJ	$\frac{3}{8}$ " x $\frac{3}{4}$ " Set Screw for fastening Rocker Pin.....	04		
02 HK	$\frac{3}{8}$ " x $1\frac{1}{4}$ " Tap Bolt for fastening Locking Bracket to Back Rail.....	04		
02 HL	$\frac{1}{2}$ " x $1\frac{1}{4}$ " Tap Bolt for fastening Top Plate to Leg....	07		
02 HM	$\frac{1}{2}$ " x $1\frac{1}{4}$ " Cap Screw for fastening Back Rails and End Blocks to Bearings.....	07		
02 HN	$\frac{3}{8}$ " x $1\frac{3}{4}$ " Machine Screw for fastening Cap to Intermediate Rail.....	05		
02 HP	$\frac{1}{2}$ " x $1\frac{3}{8}$ " Tap Bolt for fastening Latch Shoe to Lever...	02		
02 HR	$\frac{3}{8}$ " x $2\frac{1}{4}$ " Cap Screw for fastening Locking Bracket to Front Rail.....	07		
02 HS	$\frac{3}{8}$ " x $4\frac{3}{8}$ " Cap Screw for fastening Locking Bracket through End Block to Bearing.....	11		
02 HT	$\frac{3}{8}$ " x $3\frac{1}{2}$ " Machine Screw, Filister Head, for fastening Intermediate Rail to Bearing.....	10		
02 HV	Lever Number.....	07		
02 HW	Die for Rocker.....	22		
02 HX	Lever Shoe Pin, $1$ " x $4\frac{7}{8}$ ".....	09		
02 HY	Rocker Pin, $1$ " x $3$ ".....	07		
02 HZ	Swivel Pin, flat, $1$ " x $2\frac{5}{8}$ ".....	10		
02 JA	$\frac{1}{4}$ " x $1$ " Dowel pin, through Rails to Bearing and through $\frac{3}{8}$ " and $\frac{1}{2}$ " Dogs to Locking Bar.....	02		
02 JB	$\frac{1}{4}$ " x $1\frac{1}{4}$ " Dowel pin, through $\frac{3}{4}$ " Dogs to Locking Bar....	02		
02 JD	No. 7 x $1\frac{3}{4}$ " Taper Dowel Pin, through Bearing and Leg; through Top Plate and Leg; through Lever Shoe and Lever; and through Latch Shoe and Lever....	02		

ORDER No.	02. STYLE "B" (SAXBY & FARMER) INTERLOCKING MACHINE FITTINGS—Cont'd.	LIST PRICE	WEIGHT	
			LBS	OZS
02 JE	$\frac{1}{2}$ " x $1\frac{1}{8}$ " Turned pin, for fastening Latch Handle and Number Plate to Lever, and Universal Link to Locking Crank.....	06		
02 JF	$\frac{1}{2}$ " x 2" Turned Pin for fastening Swivel Pin to Universal Link.....	06		
02 JG	$\frac{1}{8}$ " x $\frac{3}{4}$ " Split cotter for 02 JE and 02 JF.....	01		

Style "B" (Saxby & Farmer) Interlocking Machine Fittings.

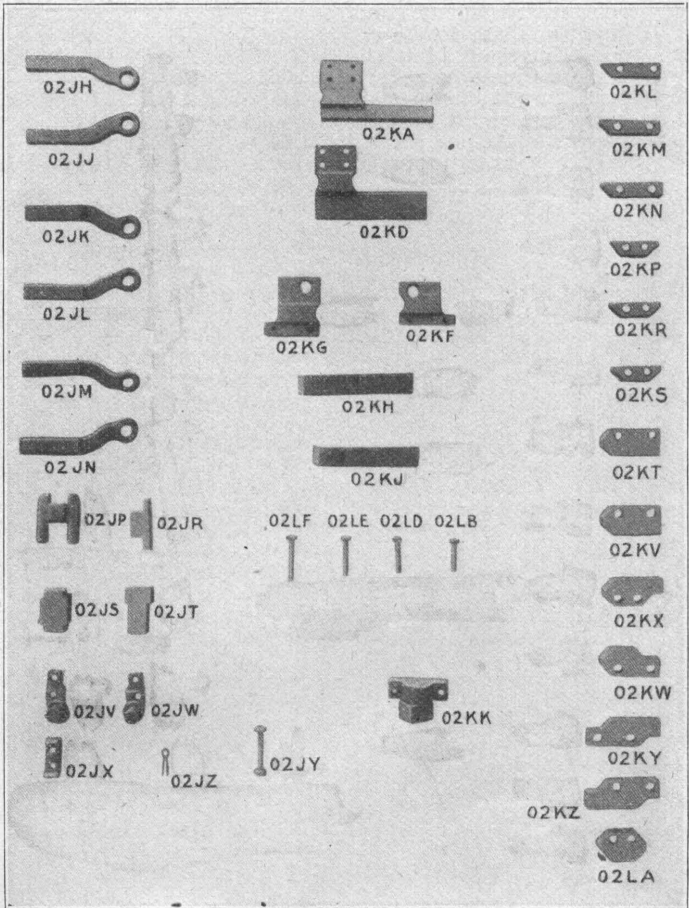

ORDER NO.	02 STYLE "B" (SAXBY & FARMER) INTERLOCKING MACHINE FITTINGS.—Cont.	LIST PRICE	WEIGHT	
			LBS	OZS
02 JH	Right-hand swing dog $\frac{3}{8}$ " thick.....	05		
02 JJ	Left hand swing dog $\frac{3}{8}$ " thick	05		
02 JK	Right-hand swing dog $\frac{1}{2}$ " thick.....	05		
02 JL	Left-hand swing dog $\frac{1}{2}$ " thick	05		
02 JM	Right-hand swing dog $\frac{3}{4}$ " thick.....	06		
02 JN	Left-hand swing dog $\frac{3}{4}$ " thick	06		
02 JP	Filling piece for locking bar	03		
02 JR	" " " Cross locks	03		
02 JS	" " " "	03		
02 JT	" " " "	03		
02 JV	Right-hand trunnion.....	15		
02 JW	Left " ".....	15		
02 JX	Splice plate for locking bar	32		
02 JY	$\frac{1}{4}$ " x $1\frac{9}{16}$ " Cap screw with hexagon nut for making splice in locking bar.....	09		
02 JZ	Split cotter for 02 JY.....	01		
02 KA	Right-hand special reach dog, $\frac{1}{2}$ " wide.....	2 31		
02 KB	Left-hand special reach dog, $\frac{1}{2}$ " wide.....	2 31		
02 KD	Right-hand special reach dog, 1" wide.....	2 38		
02 KE	Left-hand special reach dog, 1" wide.....	2 38		
02 KF	Right-hand special reach trunnion.....	82		
02 KG	Left-hand special reach trunnion.....	82		
02 KH	Steel Bar $\frac{1}{2}$ " x $\frac{3}{4}$ " for connecting locking dogs..per foot	13		
02 KJ	Steel Bar $\frac{3}{4}$ " x $\frac{3}{4}$ " for cross locking.....per foot	19		
02 KK	Driving piece and block.....	43		
02 KL	No. 1 Locking Dog $\frac{3}{8}$ " x $\frac{1}{2}$ "..	07		

ORDER NO.	02 STYLE "B" (SAXBY & FARMER) IN- TERLOCKING MACHINE FITTINGS--Cont.				LIST PRICE	WEIGHT	
						LBS	OZS
02 KM	No. 2	Locking Dog	$\frac{1}{2}$ " x $\frac{1}{2}$ "	07			
02 KN	" 3	" "	$\frac{3}{4}$ " x $\frac{1}{2}$ "	07			
02 KP	" 4	" "	$\frac{3}{8}$ " x $\frac{1}{2}$ "	08			
02 KR	" 5	" "	$\frac{1}{2}$ " x $\frac{1}{2}$ "	08			
02 KS	" 6	" "	$\frac{3}{4}$ " x $\frac{1}{2}$ "	08			
02 KT	" 7	" "	$\frac{1}{2}$ " x 1"	09			
02 KV	" 8	" "	$\frac{3}{4}$ " x 1"	11			
02 KW	" 9	" "	$\frac{3}{4}$ " x 1"	15			
02 KX	" 10	" "	$\frac{3}{4}$ " x 1"	15			
02 KY	" 13	" "	$\frac{3}{4}$ " x 1"	15			
02 KZ	" 14	" "	$\frac{1}{2}$ " x 1"	15			
02 LA	" 15	" "	$\frac{3}{4}$ " x 1"	10			
02 LB	$\frac{1}{4}$ " x $1\frac{1}{6}$	Rivet for Trunnions		01			
02 LD	$\frac{1}{4}$ " x $1\frac{7}{8}$	Rivet for locking dogs	$\frac{3}{8}$ " locking	01			
02 LE	$\frac{1}{4}$ " x $1\frac{11}{16}$	Rivet for locking dogs	$\frac{1}{2}$ " locking	01			
02 LF	$\frac{1}{4}$ " x $1\frac{13}{16}$	Rivet for locking dogs	$\frac{3}{4}$ " locking	01			

W. W. ...  
...

830101



## STYLE "C" DWARF MACHINE.

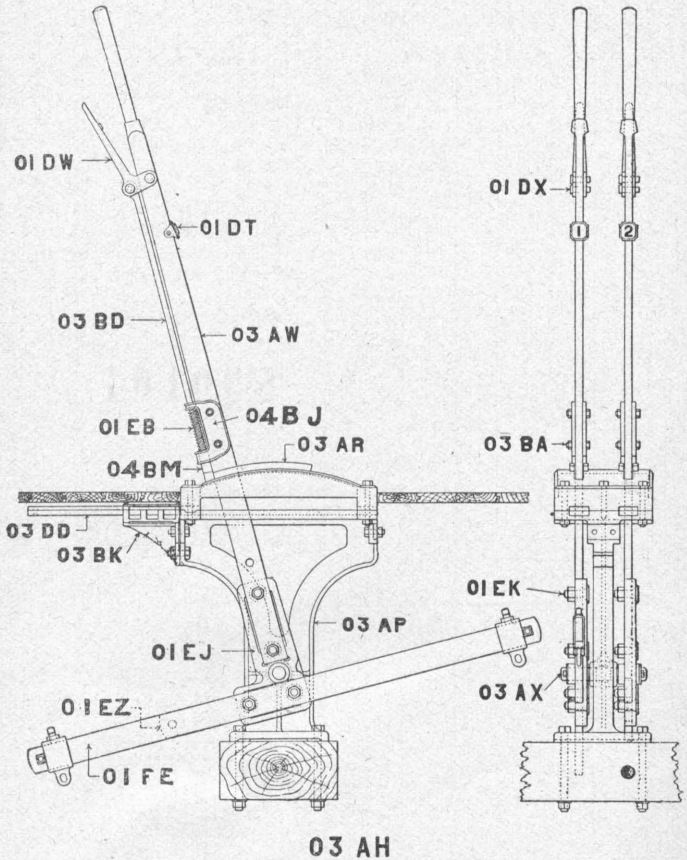

ORDER No.	03. STYLE "C" DWARF MACHINE.	LIST PRICE	WEIGHT	
			LBS	OZS
03 AA	2 Lever Machine without Locking, per lever.....	14 00		
03 AB	4 Lever Machine without Locking, per lever.....	15 00		
03 AD	6 Lever Machine without Locking, per lever.....	15 00		
03 AE	8 Lever Machine without Locking, per lever.....	15 00		
03 AF	10 Lever Machine without Locking, per lever.....	15 00		
03 AG	12 Lever Machine without Locking, per lever.....	15 00		
03 AH	2 Lever Machine with Locking, per lever.....	18 00		
03 AJ	4 Lever Machine with Locking, per lever.....	18 85		
03 AK	6 Lever Machine with Locking, per lever.....	19 75		
03 AL	8 Lever Machine with Locking, per lever.....	20 75		
03 AM	10 Lever Machine with Locking, per lever.....	21 75		
03 AN	12 Lever Machine with Locking, per lever.....	22 75		
	Spare spaces..... each	10 00		

Style "C" Dwarf Machine Fittings.

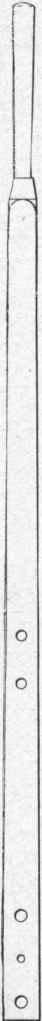

03AW

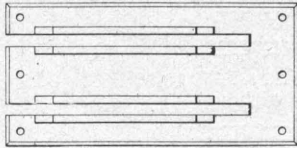

03AR

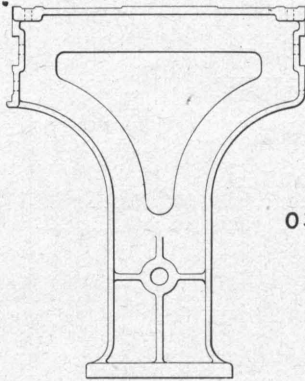

03AP

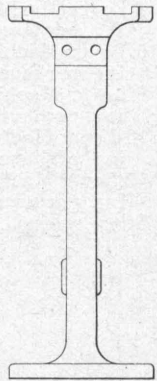

03BK

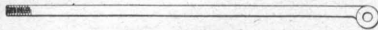
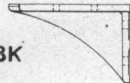

03BD

ORDER No.	03. STYLE "C" DWARF MACHINE FITTINGS.	LIST PRICE	WEIGHT	
			LBS	OZS
03 AP	Two-Lever Leg.....	7 30		
03 AR	Two-Lever top-plate.....	2 90		
03 AS	4— $\frac{1}{2}$ " x $3\frac{3}{4}$ " Bolts and Nuts ..... each	05		
03 AT	1— $\frac{1}{2}$ " x 3" Tap-bolt... each	04		
03 AV	Lever complete, including Lever, Lever Shoe, Latch Shoe, Latch Block, Latch Rod, Latch Handle, Latch Spring, Pins and Bolts. No tappet nor lever tail. These must be ordered separately, stating length of tappet and stroke of lever tail. State number required for lever when ordering.....	6 30		
03 AW	Lever.....	2 40		
01 EJ	Lever Shoe.....	1 28		
01 EK	2— $\frac{3}{4}$ " x $2\frac{1}{4}$ " Bolts with csk. hds. and hex. nuts ... each	08		
01 EL	1— $\frac{1}{2}$ " x $1\frac{3}{8}$ " Dowel Pin.....	01		
03 AX	$1\frac{1}{4}$ " x 8" Lever Centre Pin....	30		
03 AY	2— $\frac{1}{4}$ " x 2" Split Cotters.....	03		
04 BJ	Latch Shoe.....	50		
03 BA	2— $\frac{3}{8}$ " x 2" Bolts and Nuts....	03		
04 BM	Latch Block.....	55		
01 EB	Latch Spring.....	10		
01 DW	Latch Handle.....	52		
01 DX	2— $\frac{5}{8}$ " x $1\frac{7}{8}$ " Pins.....	06		
01 DY	2— $\frac{5}{8}$ " Washers.....	01		
01 DZ	2— $\frac{1}{8}$ " x 1" Split Cotters.....	01		
03 BD	Latch Rod.....	85		
01 DT	Lever Number.....	13		
01 DV	$\frac{1}{4}$ " x $1\frac{1}{2}$ " Bolt and Nut.....	01		
03 BK	Bracket to support Locking Plate 1 to each Leg.....	80		
03 BL	2— $\frac{1}{2}$ " x $1\frac{3}{4}$ " Bolts to each Bracket..... each	04		
03 BM	4 Lever Locking Plate.....	5 65		
01 GJ	4— $\frac{3}{8}$ " x $1\frac{1}{8}$ " Cap Screws.....	03		
01 DB	2— $\frac{3}{8}$ " x $1\frac{1}{8}$ " Taper Dowel Pins.....	03		
03 BN	6 Lever Locking Plate.....	8 45		
01 GJ	6— $\frac{3}{8}$ " x $1\frac{1}{8}$ " Cap Screws.....	03		
01 DB	2— $\frac{3}{8}$ " x $1\frac{1}{8}$ " Taper Dowel Pins.....	03		

ORDER No.	03. STYLE "C" DWARF MACHINE FITTINGS.—Cont.	LIST PRICE		WEIGHT	
				LBS	OZS
03 BP	8 Lever Locking Plate.....	11	25		
01 GJ	8— $\frac{3}{8}$ " x $1\frac{1}{8}$ " Cap Screws.....		03		
01 DB	2— $\frac{3}{8}$ " x $1\frac{5}{8}$ " Taper Dowel Pins.....		03		
03 BR	10 Lever Locking Plate.....	14	05		
01 GJ	10— $\frac{3}{8}$ " x $1\frac{1}{8}$ " Cap Screws.....		03		
01 DB	2— $\frac{3}{8}$ " x $1\frac{5}{8}$ " Taper Dowel Pins.....		03		
03 BS	12 Lever Locking Plate.....	16	85		
01 GJ	12— $\frac{3}{8}$ " x $1\frac{1}{8}$ " Cap Screws.....		03		
01 DB	2— $\frac{3}{8}$ " x $1\frac{5}{8}$ " Taper Dowel Pins.....		03		
03 BT	14 Lever Locking Plate.....	19	65		
01 GJ	14— $\frac{3}{8}$ " x $1\frac{1}{8}$ " Cap Screws.....		03		
01 DB	2— $\frac{3}{8}$ " x $1\frac{5}{8}$ " Taper Dowel Pins.....				
03 BV	4 Lever Locking Plate Cover		60		
03 BW	4—14-24 x $\frac{3}{4}$ " Rd. hd. Ma- chine Screws..... each		01		
03 BX	6 Lever Locking Plate Cover		90		
03 BW	6—14-24 x $\frac{3}{4}$ " Rd. hd. Ma- chine Screws..... each		01		
03 BY	8 Lever Locking Plate Cover	1	20		
03 BW	8—14-24 x $\frac{3}{4}$ " Rd. hd. Ma- chine Screws..... each		01		
03 BZ	10 Lever Locking Plate Cover	1	50		
03 BW	10—14-24 x $\frac{3}{4}$ " Rd. hd. Ma- chine Screws..... each		01		
03 DA	12 Lever Locking Plate Cover	1	80		
03 BW	12—14-24 x $\frac{3}{4}$ " Rd. hd. Ma- chine Screws..... each		01		
03 DB	14 Lever Locking Plate Cov- er.....	2	10		
03 BW	14—14-24 x $\frac{3}{4}$ " Rd. hd. Ma- chine Screws..... each		01		
03 DD	Tappet for Locking at Front or Back of Machine.....	1	70		
03 DE	Tappet for Locking at both Front and Back of Ma- chine.....	2	50		
	NOTE.—Locking Dogs same as Back Locking Dogs for style "A" Machine.				

ORDER NO.	03. STYLE "C" DWARF MACHINE FITTINGS.—Cont.	LIST PRICE	W EIGHT	
			LBS	OZS
01 EZ	Front Lever Tail 7" Stroke	66		
01 FA	Front Lever Tail 8" Stroke	71		
01 FB	Front Lever Tail 12" Stroke	90		
01 FD	Front and Back Lever Tail 12" Stroke	1 02		
01 FE	Front and Back Lever Tail 16" Stroke	1 15		
01 EK	2— $\frac{3}{4}$ " x $2\frac{1}{4}$ " Bolts with Csk. hds. and hex. nuts to each Lever Tail	08		
53 AX	Adjustable Connector	35		
53 AS	$\frac{7}{8}$ " Shackle and Pin	10		
38 HA	56 lb Balance Weight	2 80		



## STYLE "D" DWARF MACHINE.

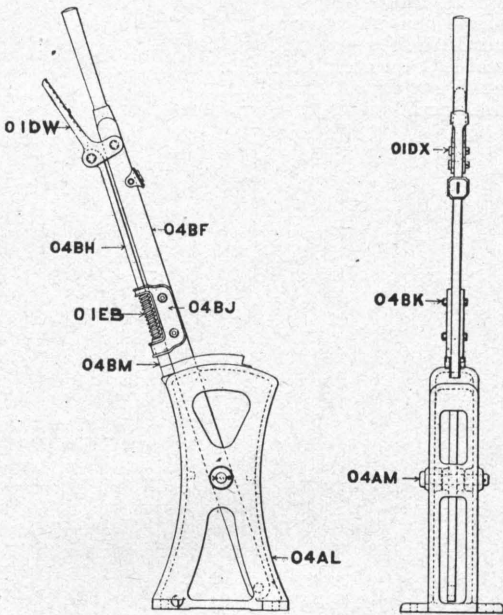

04AA

ORDER NO.	04. STYLE "D" DWARF MACHINE.	LIST PRICE		WEIGHT	
				LBS	OZS
04 AA	1 Lever complete.....	17	25		
04 AB	2 Lever complete without Locking.....	36	45		
04 AD	3 Lever complete without Locking.....	46	90		
04 AE	4 Lever complete without Locking.....	58	00		
04 AF	2 Lever complete with Locking.....	51	25		
04 AG	3 Lever complete with Locking.....	67	85		
04 AH	4 Lever complete with Locking.....	85	15		
04 AJ	6 Lever complete with Locking.....	109	10		
04 AK	8 Lever complete with Locking.....	133	00		

STYLE "D" DWARF MACHINE.

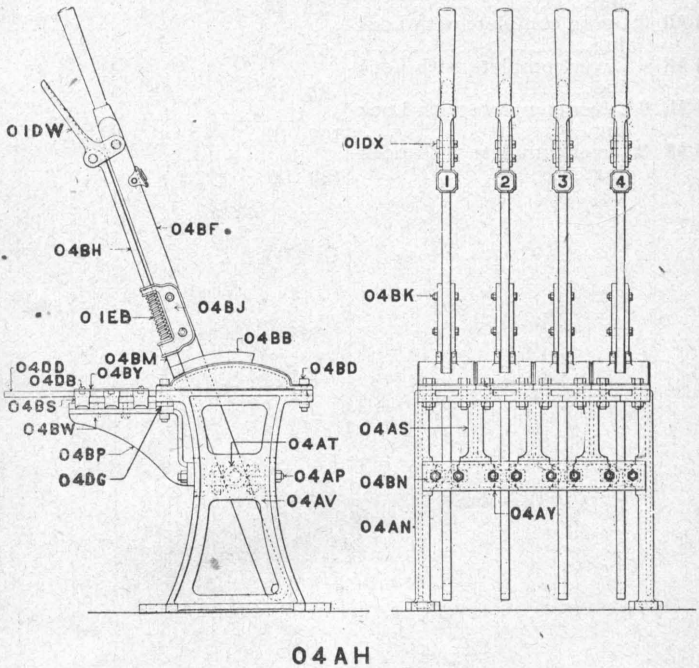

ORDER NO.	04. STYLE "D" DWARF MACHINE FITTINGS.	LIST PRICE		WEIGHT	
				LBS	OZS
04 AL	Stand for 1 Lever.....	4	30		
04 AM	1" Pin for 1 Lever Stand... }				
12 AV	2— $\frac{3}{16}$ " x 2" Split Cotters... }		16		
04 AN	End Stand.....	4	70		
04 AP	2— $\frac{1}{2}$ " x 2 $\frac{1}{4}$ " Bolts and Nuts, each			04	
04 AR	Intermediate Stand.....	4	70		
04 AP	4— $\frac{1}{2}$ " x 2 $\frac{1}{4}$ " Bolts and Nuts each			04	
04 AS	Intermediate Bracket.....	2	95		
04 AP	4— $\frac{1}{2}$ " x 2 $\frac{1}{4}$ " Bolts and Nuts each			04	
04 AT	Bearing Cap.....		21		
04 AV	2— $\frac{1}{2}$ " x 2" Bolts and Nuts each			04	
04 AW	Tie Plate for 2 Lever Machine.....		40		
04 AX	Tie Plate for 3 Lever Machine.....		60		
04 AY	Tie Plate for 4 Lever Machine.....		80		
04 AZ	Tie Plate for 6 Lever Machine.....	1	00		
04 BA	Tie Plate for 8 Lever Machine.....	1	20		
04 BB	Segment.....	1	90		
04 BD	4— $\frac{1}{2}$ " x 3 $\frac{1}{4}$ " Bolts and Nuts..		06		
04 BE	Lever complete including Lever Centre pin, Latch Shoe, Latch Block, Latch Rod, Latch Spring and Latch Handle.....	7	15		
04 BF	Lever only.....	3	45		
01 DW	Latch Handle.....		52		
01 DX	2— $\frac{3}{8}$ " x 1 $\frac{7}{8}$ " Pins..... each			06	
01 DY	2— $\frac{3}{8}$ " Washers..... "			01	
01 DZ	2— $\frac{1}{8}$ " x 1" Split Cotters "			01	
04 BH	Latch Rod.....		65		
04 BJ	Latch Shoe.....		50		
04 BK	2— $\frac{3}{8}$ " x 2" Bolts and Nuts...			03	
01 EB	Latch Spring.....		10		
04 BM	Latch Block.....		55		
04 BN	1" x 3 $\frac{1}{2}$ " Centre Pin.....		15		
04 BP	Locking Plate Bracket.....	1	00		

Note.—Two required for 3 or 4 Lever Machine and three required for 6 or 8 Lever machine.

### Style "D" Dwarf Machine Fittings.

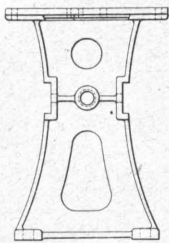

04AX

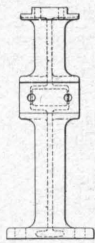
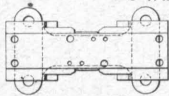

04BB



01DX

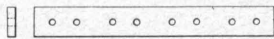

04AY

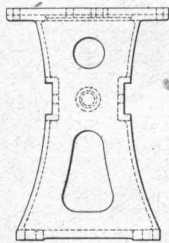

04AN

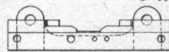

04DD

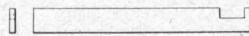

04BJ

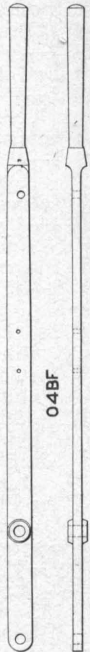

04BF

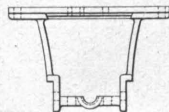

04AS



048P

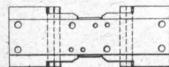
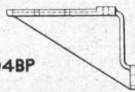

04BN



04AT

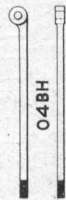
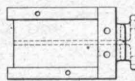

048H

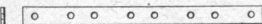

04DC



048M

ORDER NO.	04. STYLE "D" DWARF MACHINE FITTINGS.—Cont.	LIST PRICE	WEIGHT	
			LBS	OZS
04 BR	Locking Plate 2 Space for 3 Lever Machine.....	4 50		
04 BS	Locking Plate 2 Space for 4 Lever Machine.....	5 65		
04 BT	Locking Plate 2 Space for 6 Lever Machine.....	8 45		
04 BV	Locking Plate 2 Space for 8 Lever Machine.....	11 25		
04 BW	2— $\frac{3}{8}$ " x $1\frac{1}{8}$ " Tap Bolts for fixing Locking Plate to each Bracket..... each	03		
04 BX	Locking Plate Cover for 3 Lever Machine.....	45		
04 BY	Locking Plate Cover for 4 Lever Machine.....	60		
04 BZ	Locking Plate Cover for 6 Lever Machine.....	90		
04 DA	Locking Plate Cover for 8 Lever Machine.....	1 20		
04 DB	14-24 x $\frac{3}{4}$ " Rd. hd. Machine Screws. Four required for Locking Plate Cover for 3 or 4 Lever Machine and six for 6 or 8 Lever Machine..... each	01		
04 DD	Tappet..... Note.—Locking Dogs same as Back Locking Dogs for Style "A" Machine.	1 10		
04 DE	Tie bar for 2-lever Machine..	30		
04 DF	" " " 3- " "	40		
04 DG	" " " 4- " "	50		
04 DH	" " " 6- " "	70		
04 DJ	" " " 8- " "	90		



DISTANT SWITCH SIGNAL LEVER.

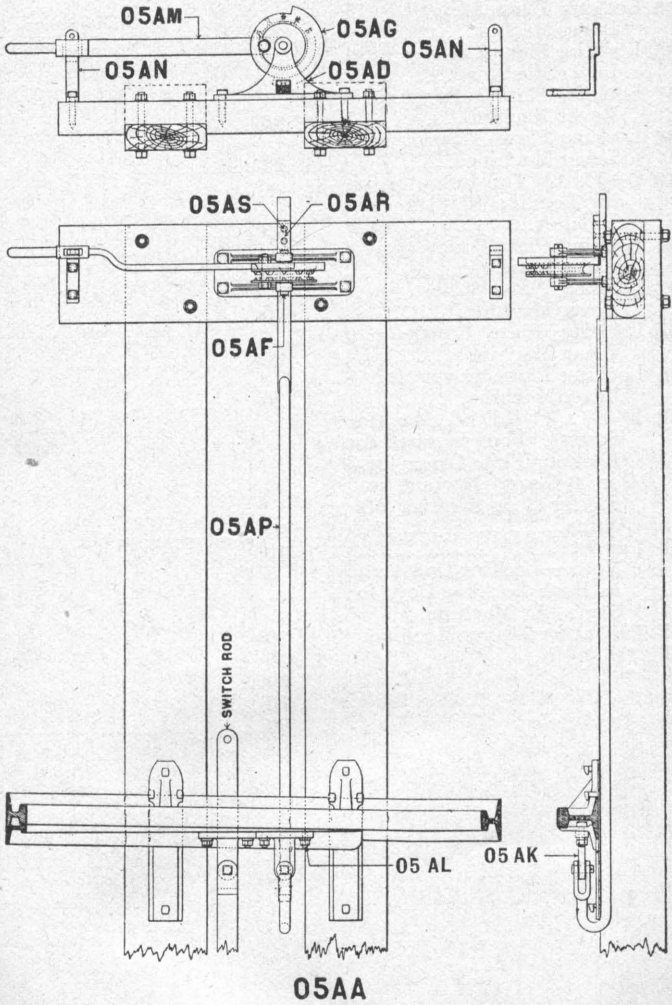

ORDER No.	05. THROW-OVER LEVERS.	LIST PRICE		WEIGHT	
				LBS	OZS
05 AA	Distant Switch Signal Lever for 10" Stroke complete...	14	50		
05 AB	Distant Switch Signal Lever for 15" Stroke complete...	14	50		
<b>FITTINGS.</b>					
05 AD	7" Wheel Stand.....	2	50		
05 AE	10" Wheel Stand.....	2	65		
05 AF	1" x 6¼" Pin and Cotters....	1	20		
05 AG	7" Wheel.....	1	35		
05 AJ	10" Wheel.....	1	50		
05 AK	Style "C" Switch Lug.....		75		
05 AL	5/8" x 2¼" Bolt and Nut.....		07		
05 AM	Lever.....	3	15		
05 AN	Lever Lock Bracket.....		55		
01 BW	2—5/8" Lock Washers....each		01		
05 AP	Front Rod.....	2	85		
05 AR	Lock Tappet.....		24		
05 AS	½" x 1¾" Rivet.....		01		

THROW OVER LEVERS.

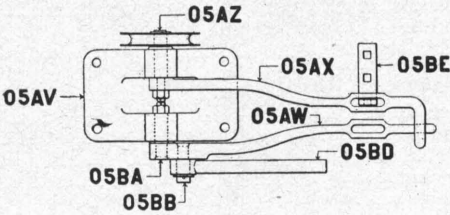
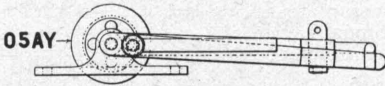

05AT

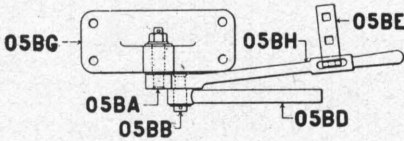
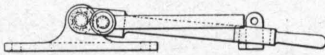

05BF

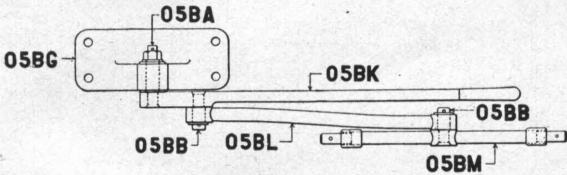
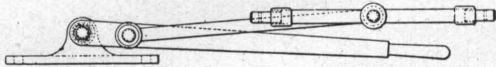

05BJ

ORDER No.	05. THROW-OVER LEVERS.—Cont.	LIST PRICE	WEIGHT	
			LBS	OZS
05 AT	Throw-over Levers complete for working Switch and Distant Signal, to be fixed on end of ties. The Signal Lever must be operated first, putting the Signal to danger before the Switch Lever can be thrown over. ....	20 00		
	<b>Fittings.</b>			
05 AV	Stand. ....			
05 AW	Switch Lever. ....			
05 AX	Signal Lever. ....			
05 AY	Wheel. ....			
05 AZ	1 1/4" x 6 3/4" Shaft. ....			
05 BA	1 1/4" x 5 3/4" Shaft. ....			
05 BB	1 1/4" x 4" Stud. ....			
05 BD	1 1/4" Eye Solid End. ....			
05 BE	Lever Lock Bracket. ....			
05 BF	P. R. R. Switch Lever complete. ....	10 50		
	<b>Fittings.</b>			
05 BG	Stand. ....			
05 BH	Lever. ....			
05 BA	1 1/4" x 5 3/4" Shaft. ....			
05 BB	1 1/4" x 4" Stud. ....			
05 BD	1 1/4" Eye Solid End. ....			
05 BE	Lever Lock Bracket. ....			
05 BJ	Throw-over Lever, Stand and Connecting Rods complete for 9" Stroke. ....	11 75		
	<b>Fittings.</b>			
05 BG	Stand. ....			
05 BK	Lever. ....			
05 BA	1 1/4" x 5 3/4" Shaft. ....			
05 BB	1 1/4" x 4" Stud. ....			
05 BL	2' 0" Connecting Rod. ....			
05 BM	1 1/4" Coupling Rod with Tang Ends. ....			

### Double Throw-Over Lever.

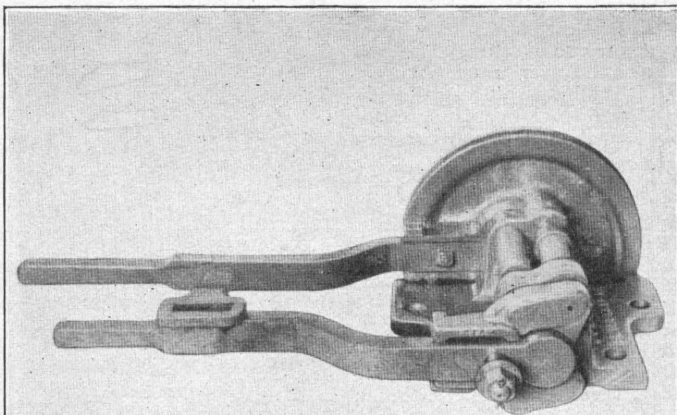

05BN

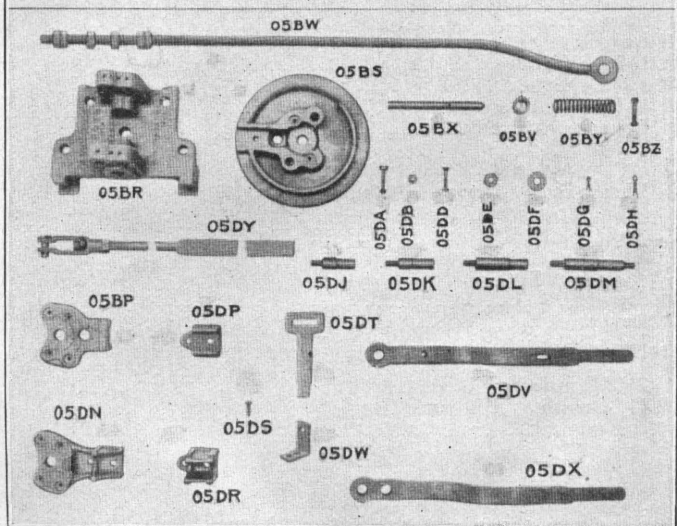

ORDER No.	05. THROW-OVER LEVERS.—Cont.	LIST PRICE		WEIGHT	
				LBS	OZS
05 BN	Double Throw-over lever complete.....	20	50		
05 BP	Lever Shoe.....		55		
05 BR	Lever Stand.....	3	20		
05 BS	Wheel (right-hand).....	2	35		
05 BT	Wheel (left-hand).....	2	35		
05 BV	Collar & dowel pin.....		06		
05 BW	Connecting rod complete with nuts.....	2	60		
05 BX	Locking pin.....		40		
05 BY	Spring for locking pin.....		60		
05 BZ	$\frac{1}{2}$ " x $2\frac{1}{2}$ " Bolt and Nut for fastening lever to wheel.....		04		
05 DA	$\frac{3}{8}$ " x $2\frac{1}{2}$ " Cheese hd. bolt and nut for filling lock holes in wheel and lever shoes.....		03		
05 DB	" Washer for bolts.....		01		
05 DD	" x $2\frac{1}{2}$ " Csk. hd. bolt and nut.....		03		
05 DE	" Hex. nut for studs.....		04		
05 DF	" Washer for studs.....		01		
05 DG	$\frac{5}{8}$ " x $1\frac{1}{2}$ " Split cotter for studs.....		01		
05 DH	$\frac{7}{8}$ " x 2" Split cotter for studs.....		01		
05 DJ	Stud for $\frac{1}{4}$ switch rod connection on switch lever.....		27		
05 DK	Stud for pipe connection on wheel.....		27		
05 DL	Stud for joining stand, switch lever and shoe.....		30		
05 DM	Stud for joining stand, signal lever and wheel.....		50		
05 DN	Lever shoe for separate lever.....		70		
05 DP	Clip used with above when lever is of flat iron.....		20		
05 DR	Clip used with above when lever is of round iron.....		30		
05 DS	Rivet for fastening clip to shoe.....		01		
05 DT	Cross-arm for signal lever.....		70		
05 DV	Signal lever.....	2	35		
05 DW	Staple.....		25		
05 DX	Switch lever.....	2	35		
05 DY	Lock rod with pin and cotter.....	2	65		



TABLE LEVERS.

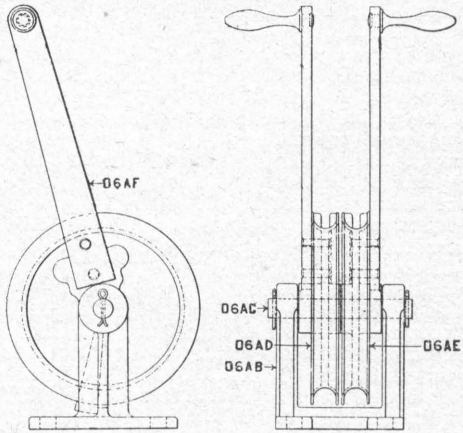

D6AA

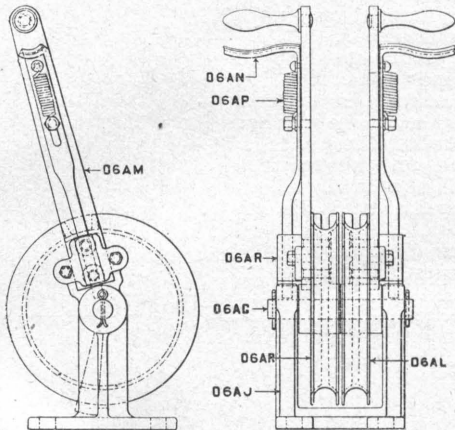

D6AH

ORDER No.	06. TABLE LEVERS For Working Block Station Signals.	LIST PRICE	WEIGHT	
			LBS	OZS
06 AA	Table Levers complete.....	8 00		
	<b>Fittings.</b>			
06 AB	Stand.....	1 25		
06 AD	Left-hand Wheel.....	1 00		
06 AE	Right-hand Wheel.....	1 00		
06 AF	Lever.....	2 00		
06 AG	1" x 7½" Pin.....	20		
06 AH	Table Levers with Latch Handles complete.....	9 00		
	<b>Fittings.</b>			
06 AJ	Stand.....	1 50		
06 AK	Left-hand Wheel.....	1 00		
06 AL	Right-hand Wheel.....	1 00		
06 AM	Lever.....	2 50		
06 AG	1" x 7½" Pin.....	20		
06 AN	Latch Handle.....	25		
06 AP	" Spring.....	12		
06 AR	" Shoe.....	25		
06 AS	Table Levers with Locking complete (same as 06AA with Locking added).....	10 50		
	<b>Fittings.</b>			
06 AT	Stand.....	1 50		
06 AV	Left-hand Wheel.....	1 25		
06 AW	Right-hand Wheel.....	1 25		
06 AF	Lever.....	2 00		
06 AG	1" x 7½" Pin.....	20		
06 AX	Locking Bolt.....	25		
06 AY	Table Levers with Latch Handles and Locking com- plete (same as 06AH with Locking added).....	11 50		
	<b>Fittings.</b>			
06 AZ	Stand.....	1 75		
06 BA	Left-hand Wheel.....	1 25		
06 BB	Right-hand Wheel.....	1 25		
06 AM	Lever.....	2 50		
06 AG	1" x 7½" Pin.....	20		
06 AN	Latch Handle.....	25		
06 AP	" Spring.....	12		
06 AR	" Shoe.....	25		
06 AX	Locking Bolt.....	25		

Lever Machines for Working Block Station or Train Order Signals.

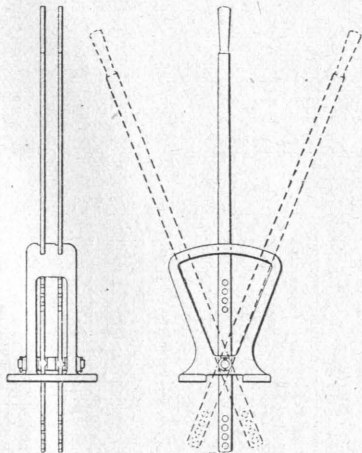

06DA

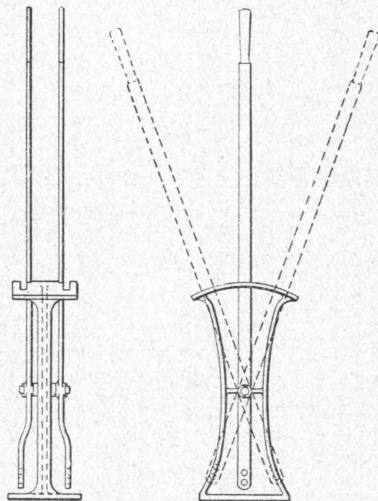

06DB

ORDER NO.	06. LEVER MACHINES FOR WORKING BLOCK STATION OR TRAIN ORDER SIGNALS.	LIST PRICE		WEIGHT	
				LBS	OZS
06 DA	2-Lever Low Stand complete	6	00	.....	.....
06 DB	2-Lever High Stand complete.....	6	00	.....	.....

Style "E" (Johnson) Interlocking Machine Fittings.

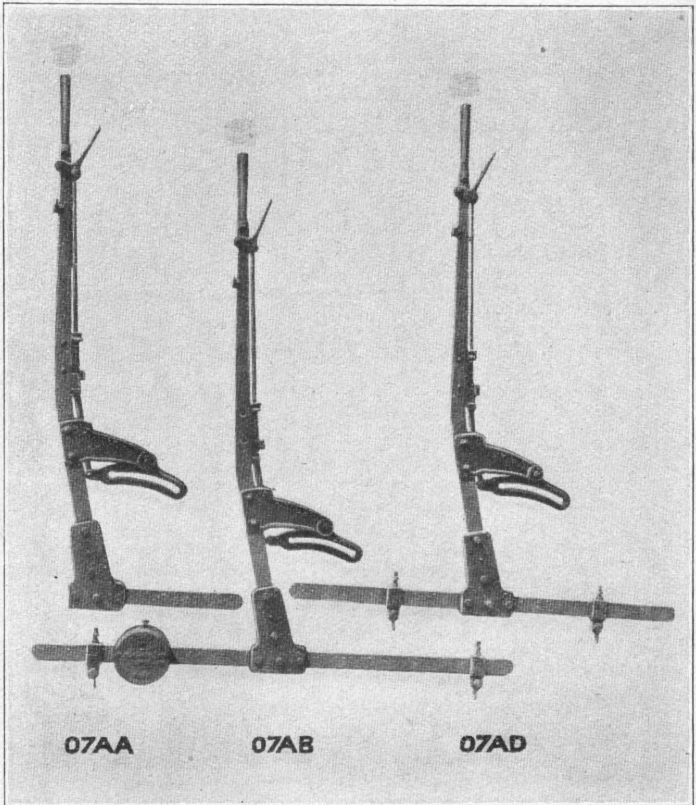

ORDER No.	07. STYLE "E" (JOHNSON) INTER- LOCKING MACHINE FITTINGS.	LIST PRICE		WEIGHT	
				LBS	OZS
07 AA	Switch Lever complete.....	18	50	.....	.....
07 AB	Distant signal complete with counterweight.....	22	50	.....	.....
07 AD	Home signal lever complete for wire connections.....	20	00	.....	.....
07 AE	Home signal lever complete for pipe connections with counterweight.....	22	50	.....	.....



### Style "E" (Johnson) Interlocking Machine Fittings.

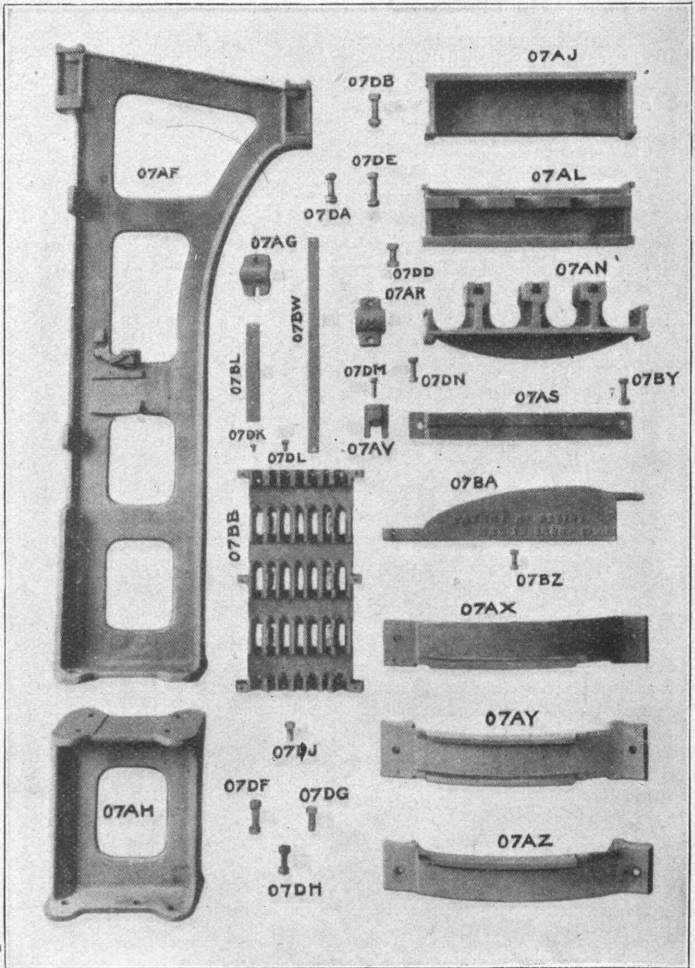

ORDER NO.	07. STYLE "E" (JOHNSON) INTER- LOCKING MACHINE FITTINGS.—Cont.	LIST PRICE		WEIGHT	
				LBS	OZS
07 AF	Machine Leg.....	17	00		
07 AG	Machine Leg Bearing Cap.....		09		
07 AH	Machine Leg Extension.....	3	50		
07 AJ	4-lever Front girder.....	2	50		
07 AK	8 lever " ".....	4	00		
07 AL	4-lever Back " ".....	3	00		
07 AM	8-lever " ".....	5	00		
07 AN	4-lever Bottom " ".....	3	75		
07 AP	8-lever Bottom girder.....	6	50		
07 AR	Bottom girder Bearing Cap.....		09		
07 AS	4-lever Tappet Girder....	2	00		
07 AT	8-lever Tappet girder.....	3	00		
07 AV	Tappet cap.....		20		
07 AW	Left-hand end plate.....		40		
07 AX	Left-hand Segment.....	2	60		
07 AY	Intermediate Segment.....	2	75		
07 AZ	Right-hand Segment.....	2	60		
07 BA	Right-hand End plate.....		40		
07 BB	4-lever 4 space Locking plate.....	6	00		
07 BD	4-lever 6 space Locking plate.....	7	00		
07 BE	4-lever 8 space Locking plate.....	8	00		
07 BF	4-lever 10 space Locking plate.....	10	00		
07 BG	8-lever 4 space Locking plate.....	7	50		
07 BH	8-lever 6 space Locking plate.....	10	00		
07 BJ	8-lever 8 space Locking plate.....	12	50		
07 BK	8-lever 10 space Locking plate.....	15	00		
07 BL	Cap for 4-lever 4 space Lock- ing plate.....		04		
07 BM	Cap for 4-lever 6 space Lock- ing plate.....		04		
07 BN	Cap for 4-lever 8 space Lock- ing plate.....		06		
07 BP	Cap for 4-lever 10 space Locking plate.....		06		
07 BR	Cap for 8-lever 4 space Lock- ing plate.....		04		
07 BS	Cap for 8-lever 6 space Lock- ing plate.....		04		
07 BT	Cap for 8-lever 8 space Lock- ing plate.....		06		
07 BV	Cap for 8-lever 10 space Locking plate.....		06		
07 BW	Tie-bar for 4-lever Locking plate.....		27		
07 BX	Tie-bar for 8-lever Locking plate.....		60		

ORDER No.	07. STYLE "E" (JOHNSON) INTER- LOCKING MACHINE FITTINGS.—Cont.	LIST PRICE	WEIGHT	
			LBS	OZS
07 BY	$\frac{1}{2}$ " x $1\frac{3}{4}$ " Bolt, hex. head and nut for fastening tappet girder to machine leg.....	02		
07 BZ	$\frac{3}{8}$ " x $1\frac{3}{8}$ " Bolt hex. head and nut for fastening end plate to segment.....	01		
07 DA	$\frac{5}{16}$ " x $2\frac{1}{4}$ " Bolt, hex. head and nut for fastening front and back girders to end leg....	03		
07 DB	$\frac{5}{8}$ " x $3\frac{1}{4}$ " Bolt, hex. head and nut for fastening front and back girders to intermediate leg.....	04		
07 DD	$\frac{5}{8}$ " x $1\frac{3}{4}$ " Bolt, hex. head and nut for fastening bottom girder to end leg.....	03		
07 DE	$\frac{5}{8}$ " x $2\frac{3}{4}$ " Bolt, hex. head and nut for fastening bottom girder to intermediate leg.....	04		
07 DF	$\frac{5}{8}$ " x $2\frac{1}{4}$ " Bolt, hex. head and nut for fastening extension to leg.....	04		
07 DG	$\frac{5}{8}$ " x $1\frac{1}{2}$ " Tap bolt hex. head for fastening segments to leg.....	02		
07 DH	$\frac{5}{8}$ " x 2" Bolt, hex. head and nut for fastening segments to front and back girders.....	03		
07 DJ	$\frac{1}{2}$ " x $1\frac{1}{4}$ " Tap Bolt, hex. head for fastening locking plate to leg.....	01		
07 DK	$\frac{1}{4}$ " x $\frac{1}{2}$ " Machine Screw for fastening cap to locking plate.....	01		
07 DL	$\frac{5}{16}$ " x 1" Tap Bolt, hex. head, for fastening tie bar to locking plate.....	01		
07 DM	$\frac{3}{8}$ " x $1\frac{1}{2}$ " Cap screw, hex. head for fastening tappet cap to tappet girder.....	04		
07 DN	$\frac{1}{2}$ " x $1\frac{3}{4}$ " Bolt, hex. head and nut for fastening bearing cap to leg and to bottom girder.....	02		



## Style "E" (Johnson) Interlocking Machine Fittings.

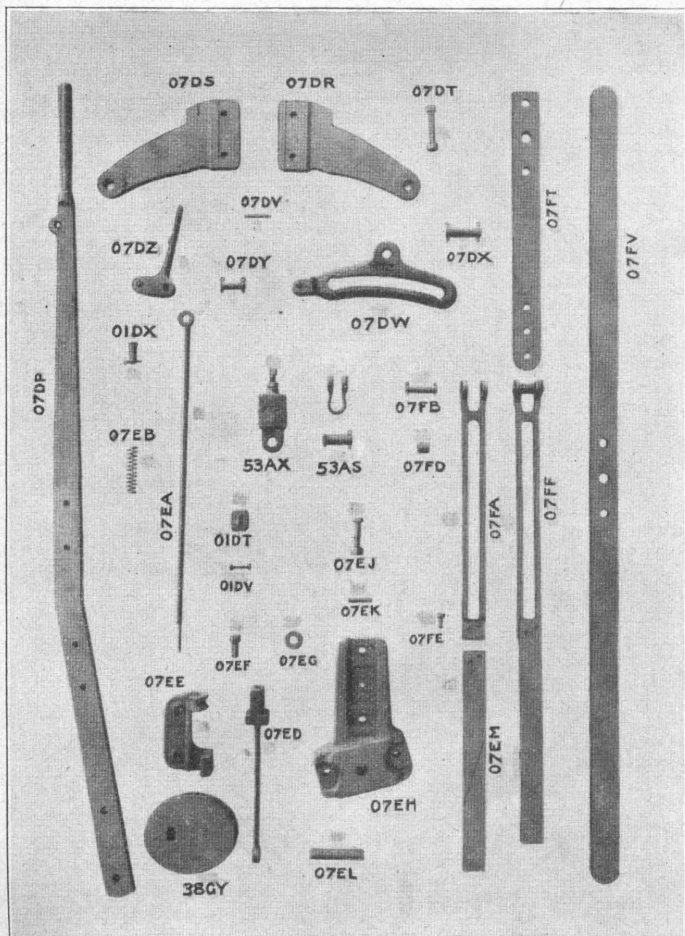

ORDER No.	07 STYLE "E" (JOHNSON) INTERLOCKING MACHINE FITTINGS—Cont.	LIST PRICE	WEIGHT	
			LBS	OZS
07 DP	Lever.....	6 50		
07 DR	Left-hand Rocker bracket...	1 00		
07 DS	Right-hand Rocker bracket	1 00		
07 DT	$\frac{5}{8}$ " x $3\frac{1}{4}$ " Bolt, hex. head and nut for fastening rocker brackets to lever.....	07		
07 DV	$\frac{1}{4}$ " x $2\frac{1}{2}$ " Dowel pin for fastening rocker brackets to lever	02		
07 DW	Rocker.....	1 50		
07 DX	1" x $3\frac{1}{4}$ " Rocker centre pin	13		
07 DY	$\frac{5}{8}$ " x $2\frac{1}{4}$ " Rocker link pin.....	07		
07 DZ	Latch Handle.....	65		
01 DX	$\frac{5}{8}$ " x $1\frac{7}{8}$ " Pin for Latch Handle.....	07		
07 EA	Latch Rod.....	40		
07 EB	Latch Spring.....	15		
07 ED	Latch Block.....	42		
07 EE	Latch Shoe.....	60		
07 EF	$\frac{5}{8}$ " x $1\frac{1}{4}$ " Cap screw for fastening Latch shoe to lever	09		
07 EG	Washer for Latch Rod.....	01		
01 DT	Lever Number.....	05		
01 DV	$\frac{1}{4}$ " x $1\frac{1}{2}$ " Bolt, sq. head and nut for fastening lever number to lever.....	02		
07 EH	Lever shoe.....	1 80		
07 EJ	$\frac{3}{4}$ " x $2\frac{3}{8}$ " Bolt, hex. head and nut for fastening lever and tail levers to lever shoe....	10		
07 EK	$\frac{7}{16}$ " x 2" Dowel pin for fastening lever to lever shoe	03		
07 EL	1" x $4\frac{3}{8}$ " Lever centre pin.....	11		
07 EM	4-space Tappet only.....	65		
07 EN	6 " " " ".....	80		
07 EP	8 " " " ".....	95		
07 ER	10 " " " ".....	1 10		
07 ES	12 " " " ".....	1 25		
07 ET	14 " " " ".....	1 40		
07 EV	16 " " " ".....	1 55		
07 EW	18 " " " ".....	1 75		
07 EX	20 " " " ".....	1 90		
07 EY	22 " " " ".....	2 00		
07 EZ	24 " " " ".....	2 10		
07 FA	Tappet Jaw.....	50		
07 FB	Tappet Jaw pin.....	06		
07 FD	Tappet Jaw roller.....	35		
07 FE	$\frac{3}{8}$ " x 1" Cap screw for fastening tappet jaw to tappet..	04		



ORDER No.	07 STYLE "E" (JOHNSON) INTERLOCK- ING MACHINE FITT- INGS—Cont.	LIST PRICE		WEIGHT	
				LBS	OZS
07 FF	4-space Tappet complete with tappet jaw.....	1	75		
07 FG	6-space Tappet complete with tappet jaw.....	1	90		
07 FH	8-space Tappet complete with tappet jaw.....	2	05		
07 FJ	10-space Tappet complete with tappet jaw.....	2	20		
07 FK	12-space Tappet complete with tappet jaw.....	2	35		
07 FL	14-space Tappet complete with tappet jaw.....	2	50		
07 FM	16-space Tappet complete with tappet jaw.....	2	70		
07 FN	18-space Tappet complete with tappet jaw.....	2	85		
07 FP	20-space Tappet complete with tappet jaw.....	3	00		
07 FR	22-space Tappet complete with tappet jaw.....	3	15		
07 FS	24-space Tappet complete with tappet jaw.....	3	35		
07 FT	Tail lever for switch.....	1	00		
07 FV	Tail lever for signal.....	2	00		
53 AX	Adjustable connector.....		35		
53 AS	$\frac{7}{8}$ " shackle and pin.....		10		
38 GY	40 lb. Counterweight com- plete.....	2	00		



Style "E" (Johnson) Interlocking Machine Fittings.

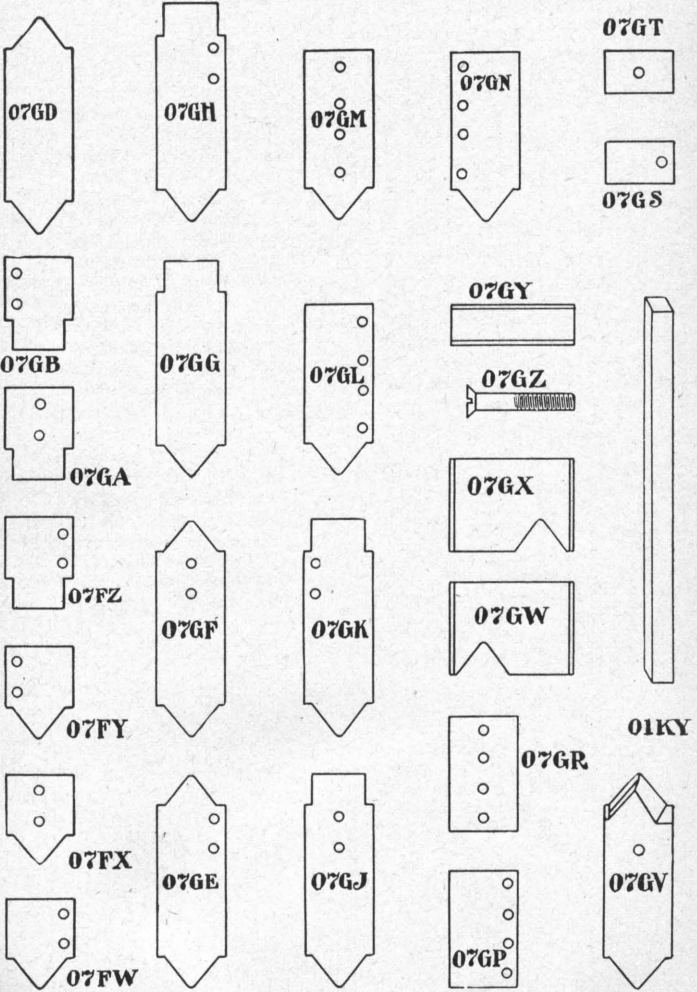

ORDER No.	07. STYLE "E" (JOHNSON) INTER- LOCKING MACHINE FITTINGS.—Cont.	LIST PRICE	WEIGHT	
			LBS	OZS
07 FW	No. 1 Locking Dog.....	18		
07 FX	No. 2 " ".....	18		
07 FY	No. 3 " ".....	18		
07 FZ	No. 4 " ".....	18		
07 GA	No. 5 " ".....	18		
07 GB	No. 6 " ".....	18		
07 GD	No. 7 " ".....	23		
07 GE	No. 8 " ".....	25		
07 GF	No. 9 " ".....	25		
07 GG	No. 10 " ".....	18		
07 GH	No. 11 " ".....	27		
07 GJ	No. 12 " ".....	27		
07 GK	No. 13 " ".....	27		
07 GL	No. 14 " ".....	27		
07 GM	No. 15 " ".....	27		
07 GN	No. 16 " ".....	27		
07 GP	No. 17 " ".....	22		
07 GR	No. 18 " ".....	22		
07 GS	No. 19 " ".....	07		
07 GT	No. 20 " ".....	07		
07 GV	No. 21 " ".....	22		
07 GW	No. 22 " ".....	20		
07 GX	No. 23 " ".....	20		
07 GY	Spacing strip.....	13		
07 GZ	10-32 x $\frac{7}{8}$ " Special steel screw for Locking Dogs.....	01		
01 KY	$\frac{3}{8}$ " x $\frac{3}{8}$ " Steel Bar for con- necting Locking Dogs.....	07		

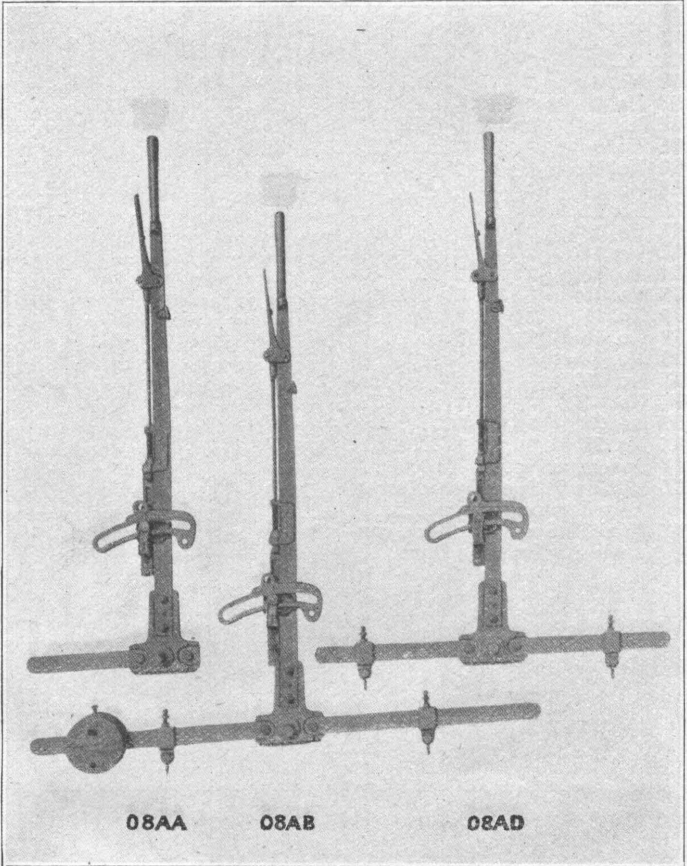
**08. Style "F" (National) Interlocking Machine Fittings**

ORDER No.	08. STYLE "F" (NATIONAL) INTER- LOCKING MACHINE FITTINGS.	LIST PRICE		WEIGHT	
				LBS	OZS
08 AA	Switch lever complete.....	15	65		
08 AB	Distant signal lever complete with counterweight.....	18	65		
08 AD	Home signal lever complete for wire connections.....	16	65		
08 AE	Home signal lever complete for pipe connections with counterweight.....	18	60		





ORDER NO.	08. STYLE "F" (NATIONAL) INTER- LOCKING MACHINE FITTINGS.—Cont.	LIST PRICE	WEIGHT	
			LBS	OZS
08 AF	Machine Leg.....	20 00		
08 AG	Machine Leg Extension.....	7 35		
08 AH	$\frac{3}{4}$ " x 3" Bolt, hex. head and nut for fastening extension to leg.....	07		
08 AJ	4 Lever Bottom girder.....	4 50		
08 AK	8 Lever Bottom girder.....	7 60		
08 AL	$\frac{5}{8}$ " x 2" Bolt, hex. head (faced) and nut for fastening Bottom Girder to end leg.....	06		
08 AM	$\frac{5}{8}$ " x 2 $\frac{1}{2}$ " Bolt, hex. head (faced) and nut for fastening Bottom Girder to intermediate leg.....	06		
08 AN	Bottom Girder Bearing Cap	09		
08 AP	$\frac{1}{2}$ " x 1 $\frac{3}{4}$ " Bolt, square shank, button head and hex. nut for fastening bearing Cap to Bottom Girder.....	04		
08 AR	4 Lever Top Plate.....	14 80		
08 AS	8 Lever Top Plate.....	25 65		
08 AT	End Strip.....	38		
08 AV	$\frac{1}{2}$ " x 1 $\frac{3}{4}$ " Bolt, button head and hex. nut for fastening top plate and end strip to leg.....	04		
08 AW	$\frac{7}{16}$ " x 2" Taper Dowel Pin for fastening top plate and locking plate to leg; and latch box and lever shoe to lever.....	02		
08 AX	Latch Handle.....	58		
08 AY	$\frac{1}{2}$ " x 2 $\frac{1}{2}$ " Latch Handle pin & $\frac{1}{8}$ " x $\frac{3}{4}$ " split cotters.....	02		
08 AZ	Latch Thimble.....	18		
08 BA	Latch Rod.....	15		
08 BB	Lever.....	3 50		
08 BD	Lever Number.....	09		
08 BE	$\frac{3}{8}$ " x 2" Lever number pin and $\frac{1}{8}$ " x $\frac{3}{4}$ " split cotters.....	02		
08 BF	Latch Shoe.....	50		
08 BG	$\frac{3}{8}$ " x 1 $\frac{3}{8}$ " Cap Screw for fastening latch shoe to lever.....	04		
08 BH	Latch Spring.....	15		
08 BJ	Latch Dog.....	1 40		
08 BK	Rocker Link Bearing.....	27		

ORDER NO.	08. STYLE "F" (NATIONAL) INTER- LOCKING MACHINE · FITTINGS.—Cont.	LIST PRICE	WEIGHT	
			LBS	OZS
08 BL	$\frac{1}{2}$ " x $1\frac{1}{2}$ " Cap Screw for fastening Rocker Link Bearing to Latch Dog .....	06		
08 BM	$\frac{3}{8}$ " x $1\frac{1}{2}$ " Dowel Pin for fastening Rocker Link Bearing to Latch Dog .....	02		
08 BN	$1\frac{1}{16}$ " x $1\frac{1}{4}$ " x $\frac{3}{4}$ " Roller for Rocker Link .....	36		
08 BP	$\frac{3}{4}$ " x $2\frac{1}{16}$ " Roller Pin and $\frac{3}{16}$ " x 2" Split Cotter .....	07		
08 BR	Latch Box .....	85		
08 BS	$\frac{3}{8}$ " x 2" Cap Screw for fastening latch box to lever .....	10		
08 BT	Lever Shoe .....	1 75		
08 BV	$\frac{5}{8}$ " x 2" Bolt, hex. head and nut for fastening lever shoe to lever .....	06		
01 EM	Lever Centre Pin .....	20		
08 BW	Hanger for Rocker .....	56		
08 BX	$\frac{1}{2}$ " x $1\frac{1}{8}$ " Cap Screw for fastening Hanger to Top Plate .....	09		
08 BY	1" x $2\frac{1}{4}$ " Pin and split cotter for Rocker Centre and Hanger .....	06		
08 BZ	Single Rocker .....	2 60		
08 DA	Double Rocker .....	2 90		
08 DB	4 Lever 4 Space Locking Plate .....	6 90		
08 DD	4 Lever 8 Space Locking Plate .....	9 10		
08 DE	4 Lever 12 Space Locking Plate .....	11 30		
08 DF	8 Lever 4 Space Locking Plate .....	9 50		
08 DG	8 Lever 8 Space Locking Plate .....	14 80		
08 DH	8 Lever 12 Space Locking Plate .....	20 70		
08 DJ	$\frac{3}{8}$ " x $1\frac{3}{8}$ " Cap Screw for fastening Locking Plate to leg. ....	04		
08 DK	Straight Cap for Locking Plate .....	03		
08 DL	Extension Cap for Locking Plate .....	06		
08 DM	$\frac{3}{8}$ " x 1" Cap Screw for fastening Caps to Locking Plate. ....	04		
08 DN	Adjustable Tappet Connection .....	60		

ORDER NO.	08. STYLE "F" (NATIONAL) INTER- LOCKING MACHINE FITTINGS.—Cont.	LIST PRICE		WEIGHT	
				LBS	OZS
08 DP	$\frac{3}{4}$ "x $1\frac{1}{8}$ " Pin and $\frac{3}{16}$ "x 2" Split Cotters for Adj. Tappet connection and Rocker....	09			
08 DR	4 space Tappet Blade.....	35			
08 DS	8 " " " ".....	50			
08 DT	12 " " " ".....	65			
08 DV	Tappet Jaw and 3- $\frac{1}{4}$ " x $1\frac{1}{4}$ " Button head Rivets.....	09			
08 DW	4 Space Tappet with Jaw complete.....	60			
08 DX	8 Space Tappet with Jaw complete.....	75			
08 DY	12 Space Tappet with Jaw complete.....	90			
08 DZ	$\frac{3}{4}$ "x $1\frac{1}{8}$ " Pin and $\frac{3}{16}$ "x2" Split cotters for Tappet and Adj. connection.....	09			
08 EA	Tail lever for switch.....	80			
08 EB	Tail lever for signal.....	1 70			
08 ED	$\frac{3}{4}$ " x $2\frac{3}{8}$ " Bolt, hex. head and nut for fastening Tail lev- ers to lever shoe.....	07			
53 AX	Adjustable connector.....	35			
38 GY	40 lb. weight.....	2 00			

Style "F" (National) Interlocking Machine Fittings.

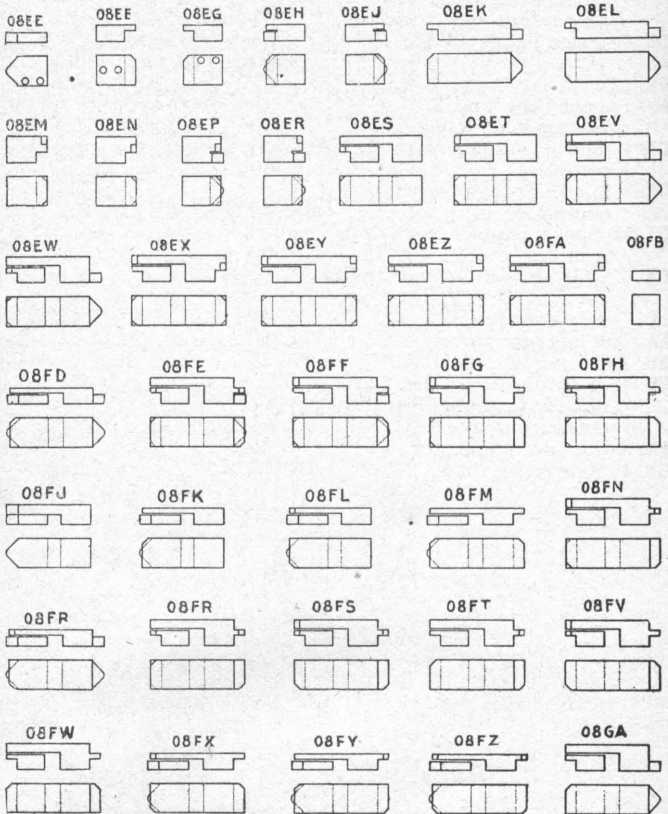

ORDER NO.	08 STYLE "F" (NATIONAL) INTER- LOCKING MACHINE FITTINGS.—Cont.	LIST PRICE		WEIGHT	
				LBS	OZS
08 EE	Locking Dog No. 10.50.....	13			
08 EF	" " " 10.51.....	15			
08 EG	" " " 10.52.....	15			
08 EH	" " " 10.53.....	42			
08 EJ	" " " 10.54.....	42			
08 EK	" " " 10.55.....	42			
08 EL	" " " 10.56.....	42			
08 EM	" " " 10.57.....	36			
08 EN	" " " 10.58.....	36			
08 EP	" " " 10.59.....	40			
08 ER	" " " 10.60.....	40			
08 ES	" " " 10.61.....	90			
08 ET	" " " 10.62.....	90			
08 EV	" " " 10.63.....	85			
08 EW	" " " 10.64.....	85			
08 EX	" " " 10.65.....	63			
08 EY	" " " 10.66.....	63			
08 EZ	" " " 10.67.....	63			
08 FA	" " " 10.68.....	63			
08 FB	" " " 10.69.....	07			
08 FD	" " " 10.70.....	75			
08 FE	" " " 10.71.....	65			
08 FF	" " " 10.72.....	65			
08 FG	" " " 10.73.....	83			
08 FH	" " " 10.74.....	83			
08 FJ	" " " 10.75.....	61			
08 FK	" " " 10.76.....	72			
08 FL	" " " 10.77.....	72			
08 FM	" " " 10.78.....	75			
08 FN	" " " 10.79.....	85			
08 FP	" " " 10.791.....	75			
08 FR	" " " 10.7910.....	85			
08 FS	" " " 10.7911.....	85			
08 FT	" " " 10.7912.....	85			
08 FV	" " " 10.7913.....	85			
08 FW	" " " 10.7914.....	85			
08 FX	" " " 10.7915.....	75			
08 FY	" " " 10.7916.....	75			
08 FZ	" " " 10.7917.....	75			
08 GA	" " " 10 7918.....	85			



Style "F" (National) Interlocking Machine Fittings.

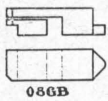

08GB

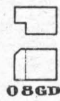

08GD

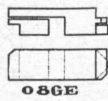

08GE

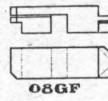

08GF

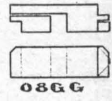

08GG

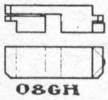

08GH

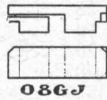

08GJ

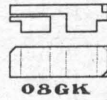

08GK

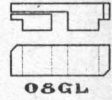

08GL

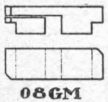

08GM

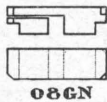

08GN

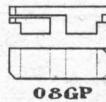

08GP

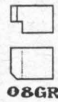

08GR

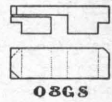

08GS

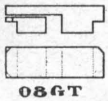

08GT

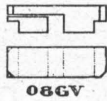

08GV

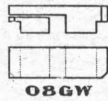

08GW

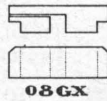

08GX

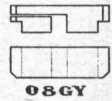

08GY

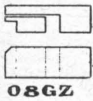

08GZ



08HA

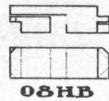

08HB

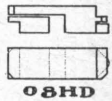

08HD

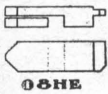

08HE

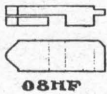

08HF



08HG

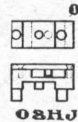

08HJ

08HH

08HK



08HL

ORDER NO.	08. STYLE "F" (NATIONAL) INTER- LOCKING MACHINE FITTINGS.—Cont.	LIST PRICE	WEIGHT	
			LBS	OZS
08 GB	Locking Dog No. 10.7919.....	85		
08 GD	" " " 10.792.....	20		
08 GE	" " " 10.7920.....	65		
08 GF	" " " 10.7921.....	65		
08 GG	" " " 10.7922.....	65		
08 GH	" " " 10.7923.....	65		
08 GJ	" " " 10.7924.....	63		
08 GK	" " " 10.7925.....	63		
08 GL	" " " 10.7926.....	60		
08 GM	" " " 10.7927.....	60		
08 GN	" " " 10.7928.....	63		
08 GP	" " " 10.7929.....	63		
08 GR	" " " 10.793.....	20		
08 GS	" " " 10.7930.....	60		
08 GT	" " " 10.7931.....	60		
08 GV	" " " 10.7932.....	60		
08 GW	" " " 10.7933.....	60		
08 GX	" " " 10.7934.....	60		
08 GY	" " " 10.7935.....	60		
08 GZ	" " " 10.794.....	90		
08 HA	" " " 10.795.....	90		
08 HB	" " " 10.796.....	65		
08 HD	" " " 10.797.....	65		
08 HE	" " " 10.798.....	75		
08 HF	" " " 10.799.....	85		
08 HG	" " " 10.95.....	42		
08 HH	" " " 10.96.....	1 10		
08 HJ	" " " 10.97.....	52		
08 HK	" " " 10.98.....	22		
08 HL	" " " 10.99.....	11		
08 HM	$\frac{1}{4}$ " x $\frac{3}{4}$ " Filister head machine screw for Locking Dog....	01		
08 HN	$\frac{1}{4}$ " x 1" Filister head machine screw for Locking Dog....	02		
08 HP	$\frac{1}{4}$ " x 1 $\frac{3}{8}$ " Filister head machine screw for Locking Dog.....	02		
	Note:— When ordering Locking Dogs state wheth- er they are to be drilled for upper, middle, or lower bar.			

### Rocking Shafts and Fittings.

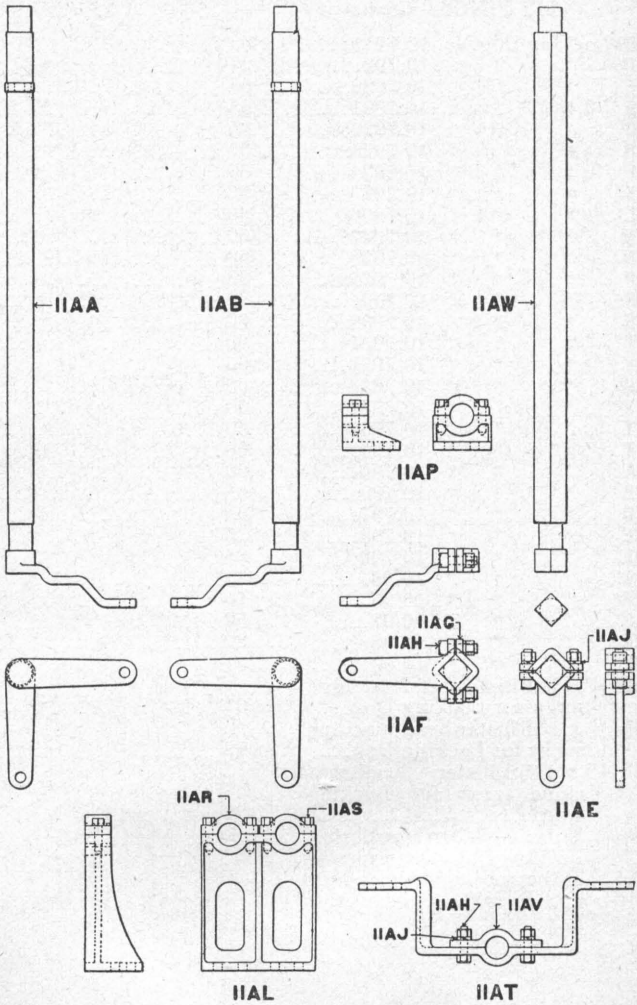

ORDER NO.	11. ROCKING SHAFTS.	LIST PRICE		WEIGHT	
				LBS	OZS
11 AA	2 $\frac{1}{4}$ " Round solid forged Rocking Shaft with 2 Arms, Left Hand.....				
11 AB	2 $\frac{1}{4}$ " Round solid forged Rocking Shaft with 2 Arms, Right Hand.....				
11 AD	2" Square Rocking Shaft with 2 Adjustable Arms. 8 Ft. long with 3 bearings Note:—When ordering Rocking Shafts state whether with 2 or 3 Journals and send sketch or drawing showing exact length of Shafts and position of Arms.	19	50		
<b>11. ROCKING SHAFT FITTINGS.</b>					
11 AE	Straight Arm.....	1	90		
11 AF	Offset Arm.....	2	10		
11 AG	Arm Clip.....		60		
11 AH	2— $\frac{3}{4}$ " x 2 $\frac{1}{2}$ " Bolts and Nuts to each Adjustable Arm each.....		07		
11 AJ	2— $\frac{3}{4}$ " Lock Washers to each Adjustable Arm.....each		01		
11 AK	1-way High Bearing complete.....	1	35		
11 AL	2-way High Bearing complete.....	2	80		
11 AM	3-way High Bearing complete.....	4	10		
11 AN	4-way High Bearing complete.....	5	40		
11 AP	1-way Low Bearing complete.....	1	10		
11 AR	Cap for Bearings.....		30		
11 AS	2— $\frac{5}{8}$ " x 1 $\frac{3}{4}$ " Cap Screws to each Cap.....		04		
11 AT	Rocking Shaft Bearing for between Ties.....	1	35		
11 AV	Cap for Bearings between Ties.....		35		
11 AH	2— $\frac{3}{4}$ " x 2 $\frac{1}{2}$ " Bolts and Nuts each.....		07		
11 AJ	2— $\frac{3}{4}$ " Lock Washers....each		01		
11 AW	2" Square Rocking Shaft only, per ft.....	1	00		

### Rocking Shafts and Fittings

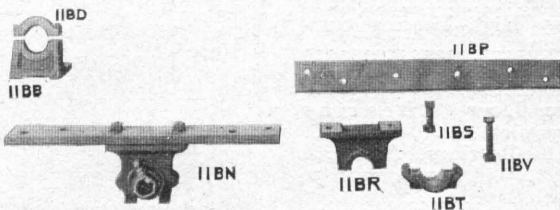
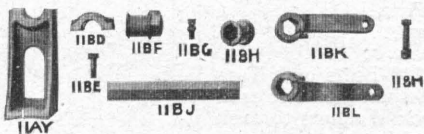
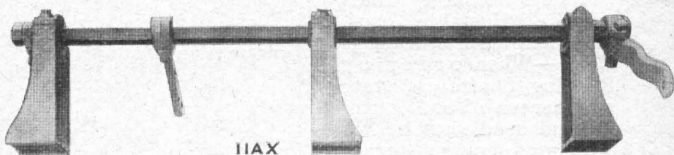

ORDER NO.	11. ROCKING SHAFTS AND FITTINGS.—Cont.	LIST PRICE	WEIGHT	
			LBS	OZS
11 AX	Hexagonal Rocking Shaft, 8 Ft. long com.....	18 70		
11 AY	1-way High Bearing for Hex. Rocking Shaft.....	1 00		
11 AZ	2-way High Bearing for Hex. Rocking Shaft.....	2 10		
11 BA	4-way High Bearing for Hex. Rocking Shaft.....	4 00		
11 BB	1-way Low Bearing for Hex. Rocking Shaft.....	70		
11 BD	Cap for Bearings.....	30		
11 BE	$\frac{5}{8}$ " x $2\frac{1}{4}$ " Tap Bolt for fastening Caps to Bearings.....	04		
11 BF	End journal for Hex. Shaft..	50		
11 BG	Intermediate journal for Hex. Shaft.....	40		
11 BH	Set screw for End journal for Hex. Shaft.....	07		
11 BJ	Hexagonal Rocking Shaft per ft.....	1 05		
11 BK	Straight arm for Hex. Shaft	1 00		
11 BL	Offset arm for Hex. Shaft..	1 08		
11 BM	$\frac{3}{4}$ " x 4" Bolt, hex. head and 2 nuts for clamping arms to shaft.....	09		
11 BN	Low Bearing for Detector Bars complete with End journal for Hex. Shaft....	4 60		
11 BP	Tie Plate for Low Bearing...	1 70		
11 BR	Low Bearing for Tie Plate...	1 20		
11 BS	$\frac{3}{4}$ " x $2\frac{3}{4}$ " Bolt, sq. hd. and nut for fastening Low Bearing to Tie Plate.....	07		
11 BT	Cap for Low Bearing.....	80		
11 BV	$\frac{3}{4}$ " x 4" Bolts, sq. head and nut for fastening Cap to Low Bearing.....	09		



Vertical Cranks and Cross Bars.

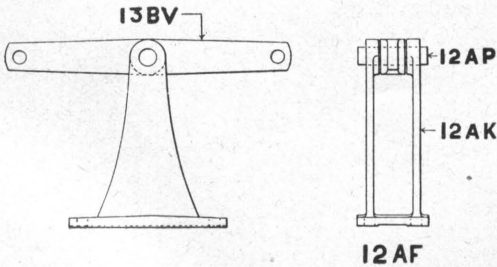
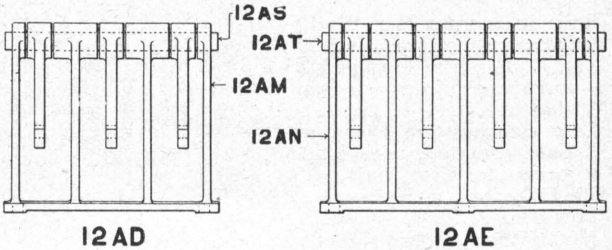
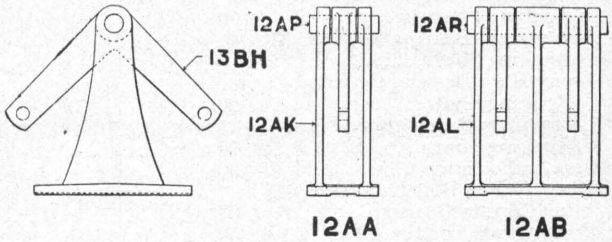

ORDER No.	12. VERTICAL CRANKS AND CROSS BARS.	LIST PRICE		WEIGHT	
				LBS	OZS
12 AA	1-way 9" x 9" Vertical Crank complete.....	2	34		
12 AB	2-way 9" x 9" Vertical Crank complete.....	4	32		
12 AD	3-way 9" x 9" Vertical Crank complete.....	6	30		
12 AE	4-way 9" x 9" Vertical Crank complete.....	8	28		
12 AF	1 way 9" x 9" Vertical Cross Bar complete.....	2	34		
12 AG	2 way 9" x 9" Vertical Cross Bar complete.....	4	32		
12 AH	3 way 9" x 9" Vertical Cross Bar complete.....	6	30		
12 AJ	4 way 9" x 9" Vertical Cross Bar complete.....	8	28		
<b>FITTINGS.</b>					
12 AK	1-way Stand.....	1	17		
12 AL	2-way Stand.....	2	16		
12 AM	3-way Stand.....	3	15		
12 AN	4-way Stand.....	4	14		
13 BH	9" x 9" Crank.....		84		
13 BV	9" x 9" Cross Bar.....		84		
12 AP	1-way Pin, 1 $\frac{1}{4}$ " x 4 $\frac{1}{2}$ ".....		15		
12 AR	2-way Pin, 1 $\frac{1}{4}$ " x 9 $\frac{1}{2}$ ".....		27		
12 AS	3-way Pin, 1 $\frac{1}{4}$ " x 14 $\frac{1}{2}$ ".....		39		
12 AT	4-way Pin, 1 $\frac{1}{4}$ " x 19 $\frac{1}{2}$ ".....		51		
12 AV	2— $\frac{3}{16}$ " x 2" Split Cotter to each Pin..... each		01		

### Horizontal Cranks.

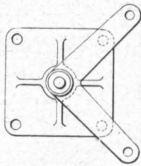

13AA

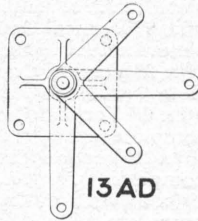

13AD

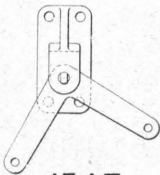

13AE

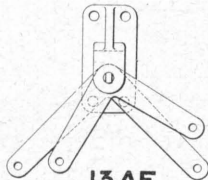

13AF

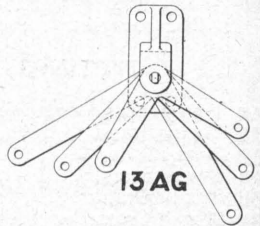

13AG

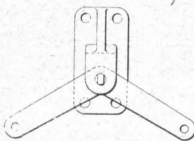

13AH

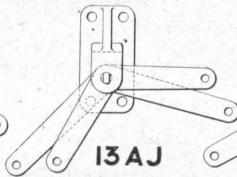

13AJ

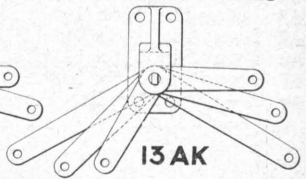

13AK

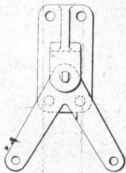

13AL

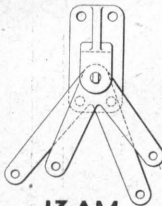

13AM

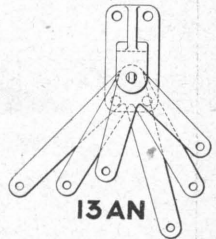

13AN

ORDER No.	13. HORIZONTAL CRANKS AND CROSS BARS, INCLUDING BOX CRANKS.	LIST PRICE	WEIGHT	
			LBS	OZS
13 AA	1-way 9" x 9" Crank and Pin Plate complete.....	2 08		
13 AB	1-way 11 $\frac{3}{4}$ " x 11 $\frac{3}{4}$ " Crank and Pin Plate complete.....	2 26		
13 AD	2-way 9" x 9" and 11 $\frac{3}{4}$ " x 11 $\frac{3}{4}$ " Crank and Pin Plate complete.....	3 51		
13 AE	1-way 9" x 9" Hor. Crank and Stand complete.....	2 08		
13 AF	2-way 9" x 9" and 11 $\frac{3}{4}$ " x 11 $\frac{3}{4}$ " Crank and Stand complete.....	3 51		
13 AG	3-way 9" x 9", 11 $\frac{3}{4}$ " x 11 $\frac{3}{4}$ " and 14 $\frac{1}{2}$ " x 14 $\frac{1}{2}$ " Crank and Stand complete.....	5 70		
13 AH	1-way 9" x 9", 120° Crank and stand complete.....	2 08		
13 AJ	2-way 9" x 9" and 11 $\frac{3}{4}$ " x 11 $\frac{3}{4}$ ", 120° Crank and stand complete.....	3 51		
13 AK	3-way 9" x 9", 11 $\frac{3}{4}$ " x 11 $\frac{3}{4}$ " and 14 $\frac{1}{2}$ " x 14 $\frac{1}{2}$ " 120° Crank and stand complete.....	5 70		
13 AL	1-way 9" x 9", 60° Crank and stand complete.....	2 08		
13 AM	2-way 9" x 9" and 11 $\frac{3}{4}$ " x 11 $\frac{3}{4}$ ", 60° Crank and stand complete.....	3 51		
13 AN	3-way 9" x 9", 11 $\frac{3}{4}$ " x 11 $\frac{3}{4}$ " and 14 $\frac{1}{2}$ " x 14 $\frac{1}{2}$ ", 60° Crank and Stand complete.....	5 70		

Horizontal "T" Cranks.

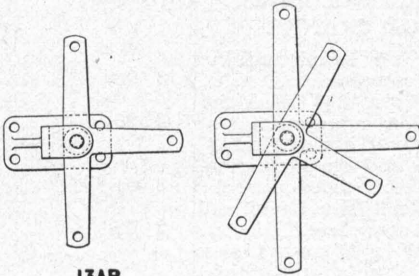

13AP

13AR

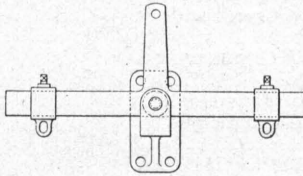

13AS

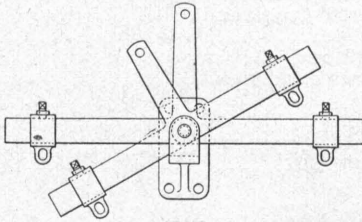

13AT

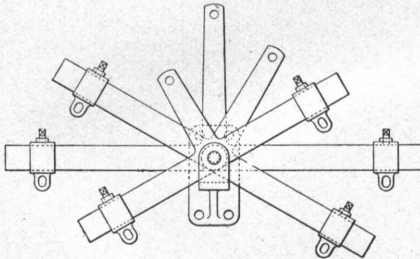

13AV

ORDER NO.	13. HORIZONTAL CRANKS AND CROSS BARS, INCLUDING BOX CRANKS.—Cont.	LIST PRICE		WEIGHT	
				LBS	OZS
13 AP	1-way 9" x 9" x 9" T Crank and Stand complete.....	2	40	.....	.....
13 AR	2-way 9" x 9" x 9" and 11 $\frac{3}{4}$ " x 11 $\frac{3}{4}$ " x 11 $\frac{3}{4}$ " T Crank and Stand complete.....	4	12	.....	.....
13 AS	1-way 9" x 15" x 15" T Crank and Stand complete with Adjustable Connectors for Draw Bridge Connections	4	35	.....	.....
13 AT	2-way 9" x 15" x 15" and 11 $\frac{3}{4}$ " x 18" x 18" T Crank and Stand complete with Adjustable Connectors for Draw Bridge Connections	7	10	.....	.....
13 AV	3-way 9" x 15" x 15", 11 $\frac{3}{4}$ " x 18" x 18" and 14 $\frac{1}{2}$ " x 21" x 21" T Crank and Stand complete with Adjustable Connectors for Draw Bridge Connections.....	10	60	.....	.....

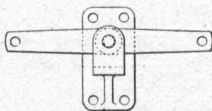
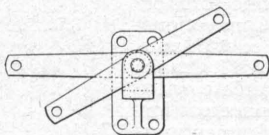
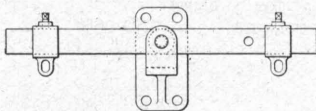
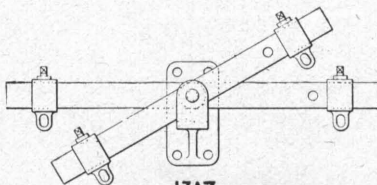
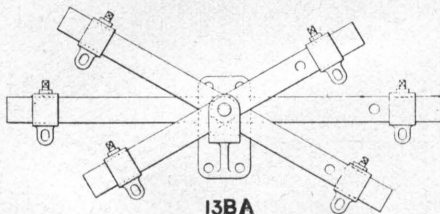

## HORIZONTAL CROSS BARS.

**13AW****13AX****13AY****13AZ****13BA**

ORDER No.	13. HORIZONTAL CRANKS AND CROSS BARS, INCLUDING BOX CRANKS.—Cont.	LIST PRICE	WEIGHT	
			LBS	OZS
13 AW	1-way 9" x 9" Hor. Cross Bar and Stand complete.....	2 08		
13 AX	2-way 9" x 9" and 11 $\frac{3}{4}$ " x 11 $\frac{3}{4}$ " Hor. Cross Bar and Stand complete.....	3 51		
13 AY	1-way 15" x 15" Hor. Cross Bar and Stand complete with Adjustable Connectors for Draw Bridge Connections.....	3 60		
13 AZ	2-way 15" x 15" and 18" x 18" Hor. Cross Bar and Stand complete with Adjustable Connectors for Draw Bridge Connections.....	5 60		
13 BA	3-way 15" x 15", 18" x 18" and 21" x 21" Hor. Cross Bar and Stand complete with Adjustable Connectors for Draw Bridge Connections.....	8 35		

Cranks and Fittings.

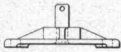
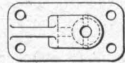
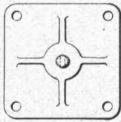

13BB

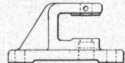

13BE

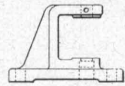

13BF

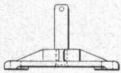

13BD

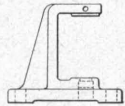

13BG

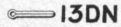

13DN

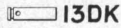

13DK

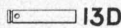

13DL

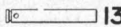

13DM



13BY



13BR

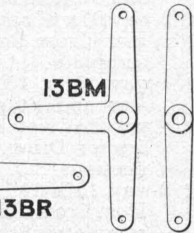

13BM

13BV



13DD

13DE

13DF

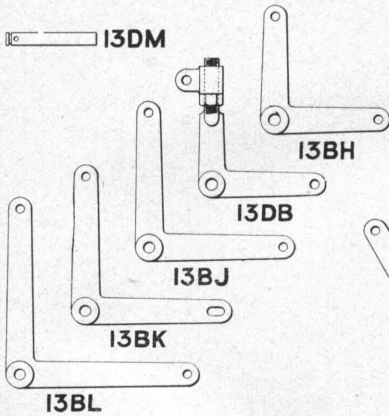

13BH

13DB

13BJ

13BK

13BL

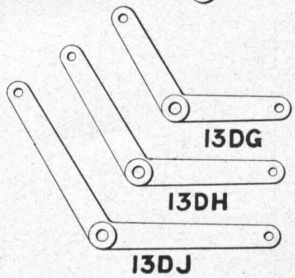

13DG

13DH

13DJ

ORDER NO.	13. Horizontal Cranks and Cross Bars Including Box Cranks. FITTINGS.	LIST PRICE	WEIGHT	
			LBS	OZS
13 BB	1-way Pin Plate and Stud...	1 13		
13 BD	2-way Pin Plate and Stud...	1 38		
13 BE	1-way Hor. Crank Stand only, drilled.....	90		
13 BF	2-way Hor. Crank Stand only, drilled.....	1 11		
13 BG	3-way Hor. Crank Stand only, drilled.....	1 20		
13 BH	9" x 9" Crank.....	84		
13 BJ	11 $\frac{3}{4}$ " x 11 $\frac{3}{4}$ " Crank.....	1 02		
13 BK	11 $\frac{3}{4}$ " x 11 $\frac{3}{4}$ " Crank, with one end slotted.....	1 40		
13 BL	14 $\frac{1}{2}$ " x 14 $\frac{1}{2}$ " Crank.....	1 92		
13 BM	9" x 9" x 9" T Crank.....	1 15		
13 BN	11 $\frac{3}{4}$ " x 11 $\frac{3}{4}$ " x 11 $\frac{3}{4}$ " T Crank..	2 26		
13 BP	14 $\frac{1}{2}$ " x 14 $\frac{1}{2}$ " x 14 $\frac{1}{2}$ " T Crank..	2 93		
13 BR	9" x 15" x 15" Crank for Adjustable Connectors.....	2 16		
13 BS	11 $\frac{3}{4}$ " x 18" x 18" Crank for Adjustable Connectors....	2 50		
13 BT	14 $\frac{1}{2}$ " x 21" x 21" Crank for Adjustable Connectors....	2 84		
13 BV	9" x 9" Horizontal Cross Bar	84		
13 BW	11 $\frac{3}{4}$ " x 11 $\frac{3}{4}$ " Horizontal Cross Bar.....	1 02		
13 BX	14 $\frac{1}{2}$ " x 14 $\frac{1}{2}$ " Horizontal Cross Bar.....	1 92		
13 BY	15" x 15" Horizontal Cross Bar for Adjustable Connectors.....	1 60		
13 BZ	18" x 18" Horizontal Cross Bar for Adjustable Connectors.....	1 75		
13 DA	21" x 21" Horizontal Cross Bar for Adjustable Connectors.....	1 90		
13 DB	9" x 9" Crank with Adjustable lug.....	1 50		
13 DD	9" x 9", 60° Crank.....	84		
13 DE	11 $\frac{3}{4}$ " x 11 $\frac{3}{4}$ ", 60° Crank. ....	1 02		
13 DF	14 $\frac{1}{2}$ " x 14 $\frac{1}{2}$ ", 60° Cranks.....	1 92		
13 DG	9" x 9", 120° Cranks.....	84		
13 DH	11 $\frac{3}{4}$ " x 11 $\frac{3}{4}$ ", 120° Cranks....	1 02		
13 DJ	14 $\frac{1}{2}$ " x 14 $\frac{1}{2}$ " 120° Cranks....	1 92		
13 DK	1-way Crank Pin 1 $\frac{1}{4}$ " x 4".....	16		
13 DL	2-way Crank Pin 1 $\frac{1}{4}$ " x 6".....	20		
13 DM	3-way Crank Pin 1 $\frac{1}{4}$ " x 8".....	24		
13 DN	1—1 $\frac{1}{4}$ " x 3 $\frac{1}{2}$ " Split Cotter to each Pin.....	01		

Lead-out Cranks.

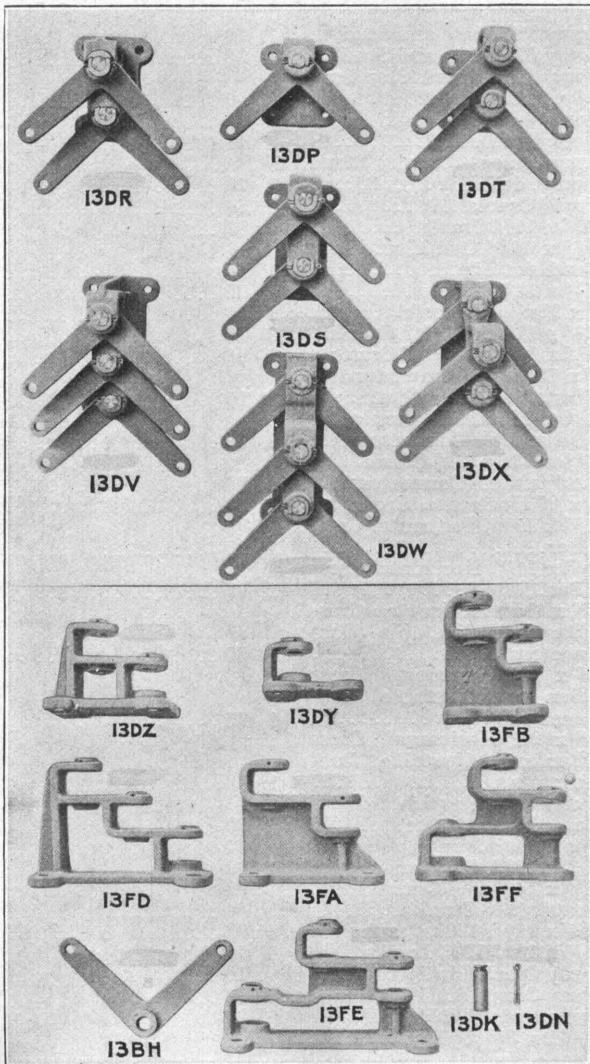

ORDER NO.	LEAD-OUT CRANKS.	LIST PRICE	WEIGHT	
			LBS	OZS
13 DP	1-way Lead-out Crank complete.....	2 08		
13 DR	2-way Style 1, Lead-out Crank complete.....	3 65		
13 DS	2-way Style 2, Lead-out Crank complete.....	3 90		
13 DT	2-way Style 3, Lead-out Crank complete.....	3 47		
13 DV	3-way Style 1, Lead-out Crank complete.....	5 40		
13 DW	3-way Style 2, Lead-out Crank complete.....	5 32		
13 DX	3-way Style 3, Lead-out Crank complete.....	4 84		
13 DY	1-way Stand for Lead-out Crank.....	90		
13 DZ	2-way Stand style 1, for Lead-out Crank.....	1 45		
13 FA	2-way Stand style 2, for Lead-out Crank.....	1 83		
13 FB	2-way Stand style 3, for Lead-out Crank.....	1 40		
13 FD	3-way Stand style 1, for Lead-out Crank.....	2 10		
13 FE	3-way Stand style 2, for Lead-out Crank.....	2 44		
13 FF	3-way Stand style 3, for Lead-out Crank.....	2 19		
13 BH	9" x 9" Crank.....	84		
13 DK	1 1/4" Crank Pin.....	16		
13 DN	1/4" x 3 1/2" Split Cotter.....	01		



STYLE "A" BOX CRANKS.

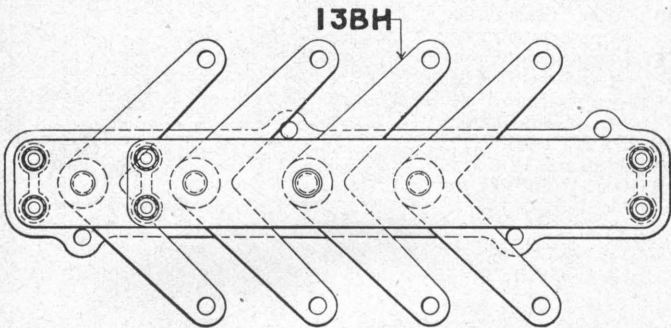
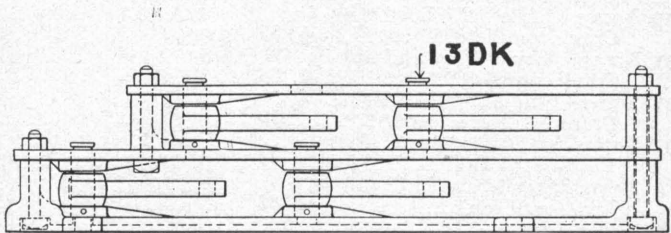

13FH

ORDER No.	13. STYLE "A" BOX CRANKS.	LIST PRICE	WEIGHT	
			LBS	OZS
13 FG	3-way 9" x 9" Box Crank Style "A" complete.....	11 85		
13 FH	4-way 9" x 9" Box Crank Style "A" complete.....	12 75		
13 FJ	5-way 9" x 9" Box Crank Style "A" complete.....	17 00		
13 FK	6-way 9" x 9" Box Crank Style "A" complete.....	17 90		
13 FL	7 way 9" x 9" Box Crank Style "A" complete.....	22 00		
13 FM	8-way 9" x 9" Box Crank Style "A" complete.....	22 90		
13 FN	9-way 9" x 9" Box Crank Style "A" complete.....	26 50		
13 FP	10-way 9" x 9" Box Crank Style "A" complete.....	27 40		
13 FR	11-way 9" x 9" Box Crank Style "A" complete.....	30 60		
13 FS	12-way 9" x 9" Box Crank Style "A" complete.....	31 50		
13 FT	13-way 9" x 9" Box Crank Style "A" complete.....	35 50		
13 FV	14-way 9" x 9" Box Crank Style "A" complete.....	36 40		
13 FW	15-way 9" x 9" Box Crank Style "A" complete.....	40 00		
13 FX	16-way 9" x 9" Box Crank Style "A" complete.....	40 90		
13 BH	9" x 9" Crank.....	84		
13 DK	1 1/4" x 4" Pin.....	16		
13 DN	1-1/4" x 3 1/2" Split Cotter to each Pin.....	01		

STYLE "B" MULTIPLE BOX CRANKS.

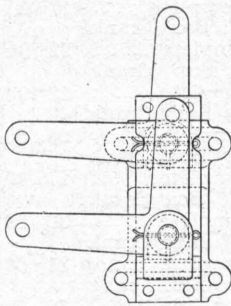
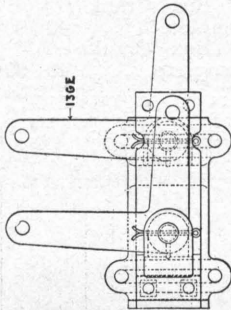
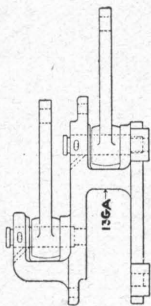
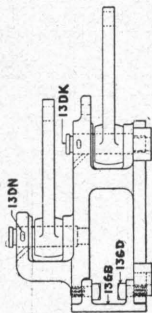

13FY

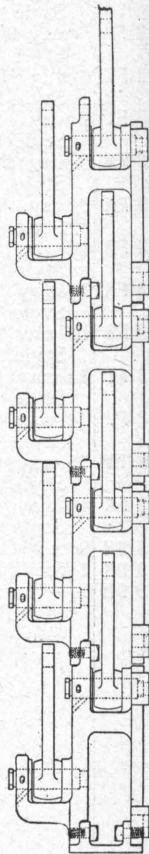

ORDER No.	13. STYLE "B" MULTIPLE BOX CRANKS.	LIST PRICE		WEIGHT	
				LBS	OZS
13 FY	2-way Section with End Plate complete.....	5	00		
13 FZ	2-way Section without End Plate complete.....	4	50		
13 GA	2-way Stand only, drilled and tapped.....	2	50		
13 GB	End Plate drilled.....		27		
13 GD	2— $\frac{5}{8}$ " x $1\frac{1}{8}$ " Tap Bolts to each Stand and each End Plate..... each		03		
13 GE	$7\frac{1}{2}$ " x 9" Crank.....		84		
13 DK	$1\frac{1}{4}$ " x 4" Pin.....		16		
13 DN	$\frac{1}{4}$ " x $3\frac{1}{2}$ " Split Cotter.....		01		

## Crank in Water-tight Boxes.

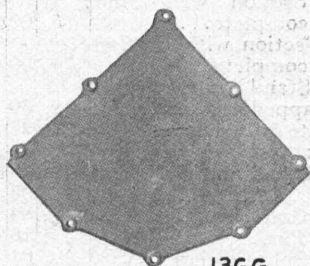

13GG

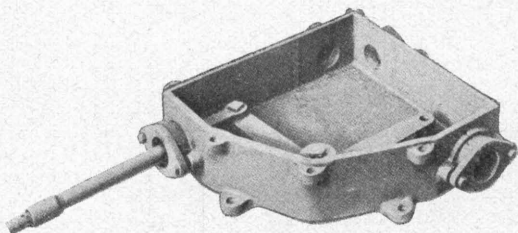

13GF

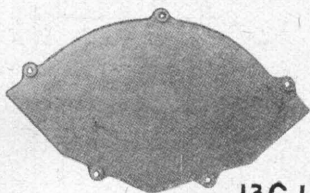
I  
13GK

13GJ

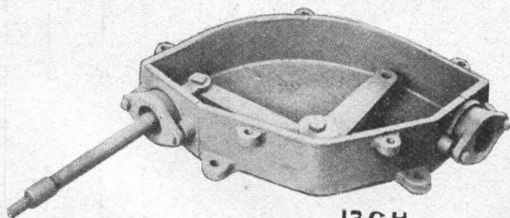

13GH

ORDER No.	CRANKS IN WATER-TIGHT BOXES.	LIST PRICE		WEIGHT	
				LBS	OZS
13 GF	Water-tight crank Box with four openings complete with stuffing boxes, crank and jaws.....	22	00		
13 GG	Cover for 13-GF.....	5	50		
13 GH	Water-tight crank box with two openings complete with stuffing boxes, crank and jaws.....	17	00		
13 GJ	Cover for 13-GH.....	4	25		
13.GK	$\frac{5}{8}$ " x 2 $\frac{1}{8}$ " Bolt and nut for fastening covers to water-tight crank boxes.....		06		



PIPE COMPENSATORS.

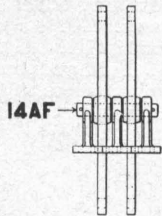
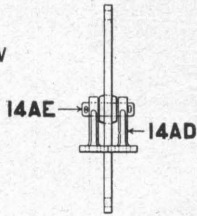
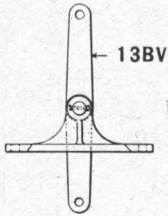

14AA

14AB

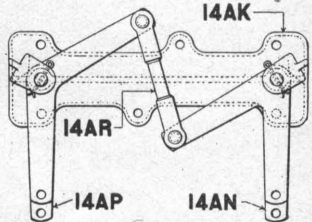
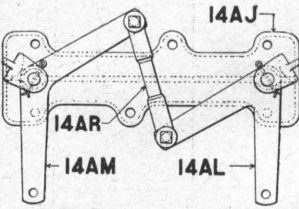
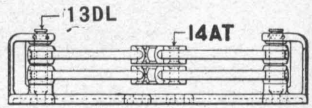
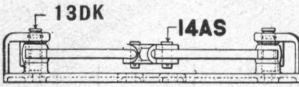

14AG

14AH

ORDER NO.	14. PIPE COMPENSATORS.	LIST PRICE	WEIGHT	
			LBS	OZS
	NOTE:—Vertical Compensators are adapted for use on Draw Bridges where they are fixed on the ties. They can be built up to any number of ways by adding a side (half-stand) and cross bar for each way required over a 1-way and using the proper length of Pin, the Pins being $2\frac{3}{4}$ " longer for each way added.			
14 AA	1-way 9" x 9" Vertical Compensator complete.....	2 17		
14 AB	2-way 9" x 9" Vertical Compensator complete.....	3 81		
14 AD	Side (half-stand) drilled.....	50		
13 BV	9" x 9" Cross Bar.....	84		
14 AE	1-way Pin $1\frac{1}{4}$ " x $4\frac{1}{2}$ ".....	14		
14 AF	2-way Pin $1\frac{1}{4}$ " x $7\frac{1}{4}$ ".....	20		
12 AV	2— $\frac{3}{16}$ " x 2" Split Cotters to each Pin.....each	01		
14 AG	1-way Lazy Jack Compensator complete.....	6 30		
14 AH	2-way Lazy Jack Compensator complete.....	11 30		
14 AJ	1-way Stand only, drilled....	2 17		
14 AK	2-way Stand only, drilled....	2 32		
13 DK	$1\frac{1}{4}$ " x 4" Pin.....	16		
13 DL	$1\frac{1}{4}$ " x 6" Pin.....	20		
13 DN	$1\frac{1}{4}$ " x $3\frac{1}{2}$ " Split Cotter to each Pin.....	01		
14 AL	1-way 60° Crank 11" x 11"....	97		
14 AM	1-way 120° Crank 11" x 11"....	97		
14 AN	2-way 60° Crank 11" x $13\frac{3}{4}$ "....	1 47		
14 AP	2-way 120° Crank 11" x $13\frac{3}{4}$ "....	1 47		
14 AR	Coupling Link.....	1 33		
14 AS	$\frac{7}{8}$ " x $2\frac{1}{2}$ " Pin for 1-way Coupling Link.....	06		
14 AT	$\frac{7}{8}$ " x 2" Pin for 2-way Coupling Links.....	06		

Angle Bars and Radial Cranks.

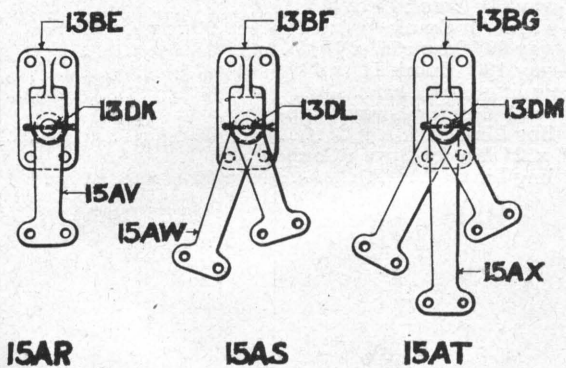
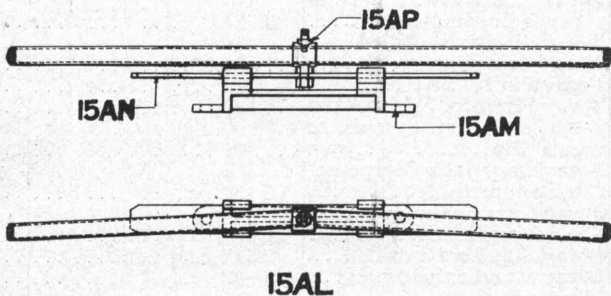
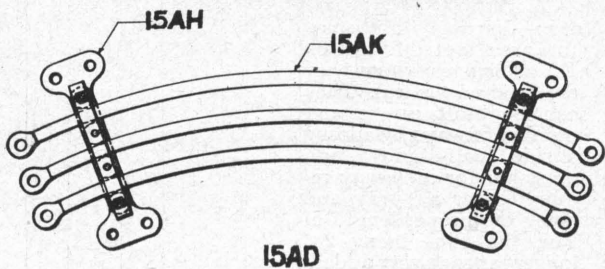

ORDER NO.	15. ANGLE BARS AND RADIAL CRANKS.	LIST PRICE		WEIGHT	
				LBS	OZS
15 AA	1-way Angle Bar complete, Style "A" .....	2	00		
15 AB	2-way Angle Bar complete, Style "A" .....	3	16		
15 AD	3-way Angle Bar complete, Style "A" .....	4	33		
15 AE	4-way Angle Bar complete, Style "A" .....	5	50		
15 AF	1-way Stand for Angle Bar, Style "A" .....		36		
15 AG	2-way Stand for Angle Bar, Style "A" .....		48		
15 AH	3-way Stand for Angle Bar, Style "A" .....		60		
15 AJ	4-way Stand for Angle Bar, Style "A" .....		72		
15 AK	Angle Bar .....	1	00		
15 AL	1-way Angle Bar complete, Style "B" .....	1	50		
15 AM	1-way Stand for Angle Bar, Style "B" .....		75		
15 AN	Slide .....		50		
15 AP	Trunnion .....		25		
	Note:—Style "B" Angle Bars can be placed side by side for any number of pipes				
15 AR	1-way Radial, or One-arm, Crank and Stand complete	1	89		
15 AS	2-way 9" and 11 $\frac{3}{4}$ " Radial, or One-arm, Crank and Stand complete .....	2	97		
15 AT	3-way 9", 11 $\frac{3}{4}$ " and 14 $\frac{1}{2}$ " Radial, or One-arm, Crank and Stand complete .....	4	75		
13 BE	1-way Hor. Crank Stand .....		90		
13 DK	1-way Hor. Crank Stand Pin, 1 $\frac{1}{4}$ " x 4" .....		16		
13 BF	2-way Hor. Crank Stand .....	1	11		
13 DL	2-way Hor. Crank Stand Pin 1 $\frac{1}{4}$ " x 6" .....		20		
13 BG	3-way Hor. Crank Stand .....	1	20		
13 DM	3-way Hor. Crank Stand Pin 1 $\frac{1}{4}$ " x 8" .....		24		
15 AV	9" Radial or One-arm Crank .....		72		
15 AW	11 $\frac{3}{4}$ " Radial or One-arm Crank .....		80		
15 AX	14 $\frac{1}{2}$ " Radial or One-arm Crank .....	1	60		

Inside Facing Lock Point.

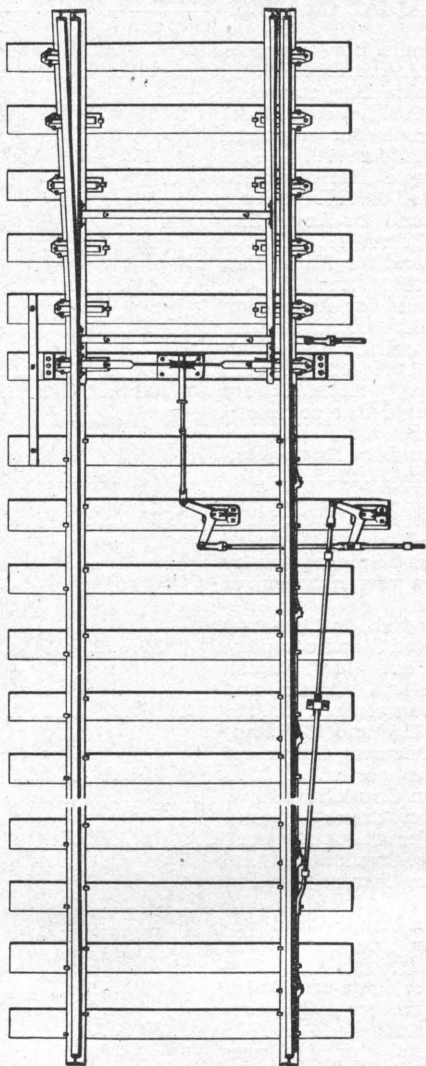

16AA

ORDER NO.

**16. INSIDE FACING POINT LOCKS.**

LIST PRICE

WEIGHT

LBS OZS

16 AA

Inside Facing Point Lock with Detector bar complete, for Switch including Front Rod and Lugs; Horizontal Cranks and Jaws; no bolt-lock.....  
When ordering send drawing of Rail Section.

42 00 .....



Inside Facing Point Lock

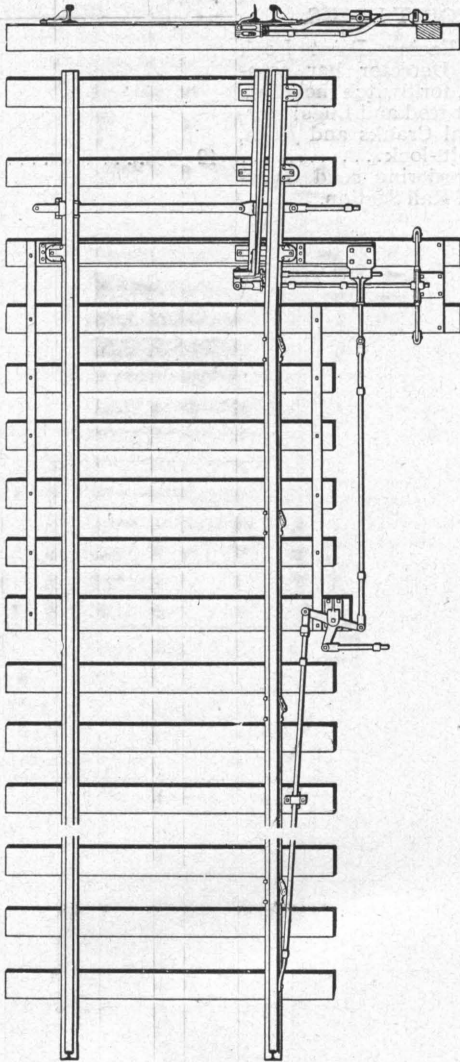

16AB



Outside Facing Point Lock

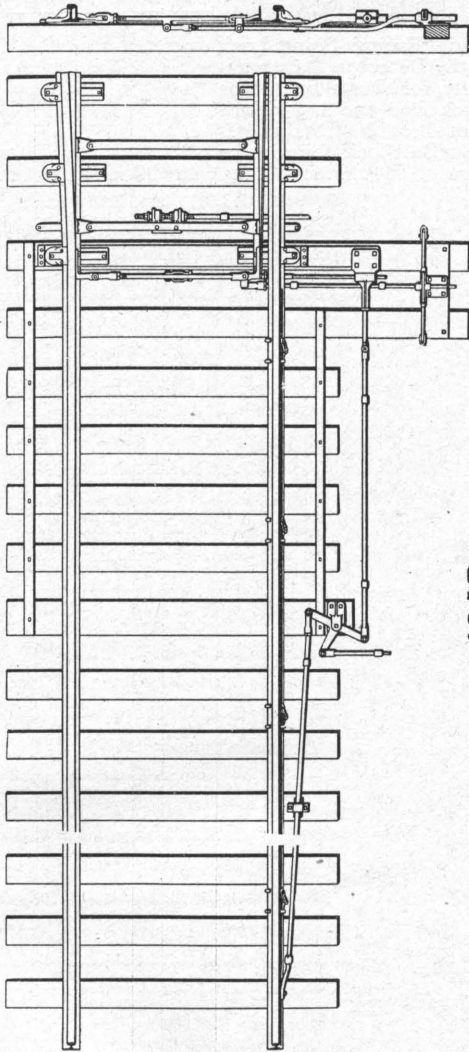

16AD

ORDER No.	16. OUTSIDE FACING POINT LOCK.	LIST PRICE	WEIGHT	
			LBS	OZS
16 AD	Outside Facing Point Lock with Detector Bar ahead of points complete for Switch including Front and Lock Rods and Lugs, Horizontal Crank, Jaws and 1-way Bolt-lock for pipe or wire.....	54 60	.....	.....

Outside Facing Point Lock.

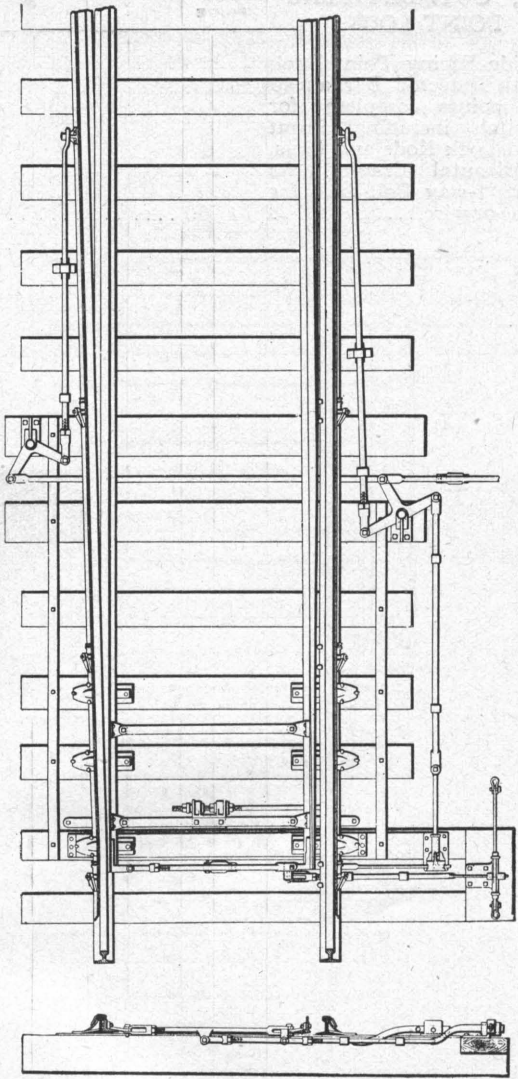

16AE

ORDER No.	16. OUTSIDE FACING POINT LOCK.	LIST PRICE		WEIGHT	
				LBS	OZS
16 AE	Outside Facing Point Lock with Detector bar in rear of points complete for Switch including Front and Lock Rods and Lugs, Horizontal Cranks, Jaws and 1-way Bolt-lock for pipe or wire.....	88	50	.....	.....



FACING POINT LOCK FITTINGS.

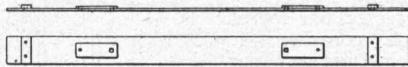

16AF

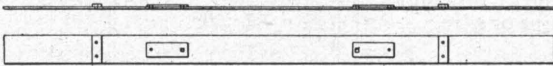

16AG

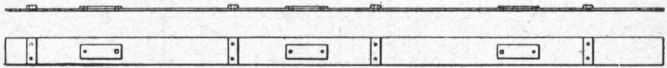

16AH



16AJ



16AL

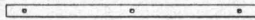

16AN



16AK



16AM



16AP

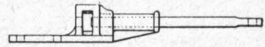

16AR

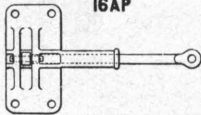

16AT



16AS

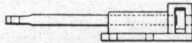

16AV

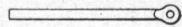

16AW

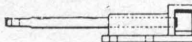
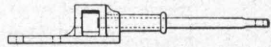
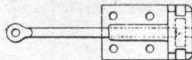

ORDER NO.	16. FACING POINT LOCK.—Cont.	LIST PRICE		WEIGHT	
				LBS	OZS
	<b>FITTINGS.</b>				
16 AF	<sup>6063</sup> 6" x 6" x 7' 4" iron Tie Plate with End Strips, Riser Plates and Rivets complete.....	4	00		
16 AG	<sup>6063</sup> 6" x 6" x 10' iron Tie Plate with End Strips, Riser Plates and Rivets complete for movable point Frogs.....	5	00		
16 AH	<sup>6063</sup> 6" x 6" x 12' iron Tie Plate with End Strips, Riser Plates and Rivets complete for Double Slips.....	6	25		
16 AJ	End Strip.....		12		
16 AK	<sup>6065</sup> 1" x 1" Rivet.....		01		
16 AL	Riser Plate.....		24		
16 AM	<sup>1</sup> / <sub>2</sub> " x <sup>7</sup> / <sub>8</sub> " Rivet.....		10		
16 AN	<sup>1</sup> / <sub>2</sub> " x 2 <sup>1</sup> / <sub>2</sub> " x 4' 7" Tie Bar.....	1	05		
16 AP	Inside Plunger Stand and Plunger complete.....	2	00		
16 AR	Outside Plunger Stand and Plunger complete.....	1	95		
16 AS	Outside Plunger Stand and Plunger complete for two Blades for movable point Frog.....	2	10		
16 AT	Outside Plunger Stand and Plunger complete for reversed Connections, for one Blade.....	1	65		
16 AV	Outside Plunger Stand and Plunger complete for reversed Connections, for two Blades.....	1	75		
16 AW	Steel Plunger.....		45		

Style "A" Switch and Lock Movement.

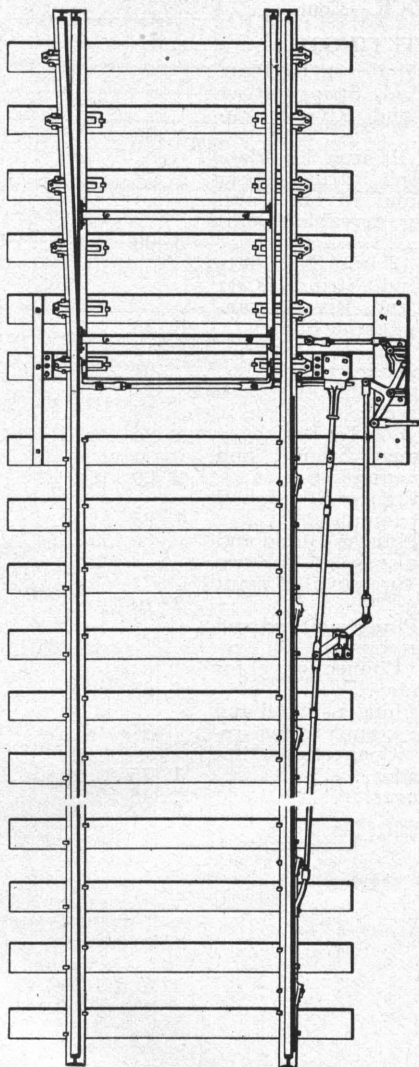

17AA

ORDER NO.	17. STYLE "A" SWITCH AND LOCK MOVEMENT.	LIST PRICE	WEIGHT	
			LBS	OZS
17 AA	Style "A" Switch and Lock Movement with Detector Bar complete for Switch; including Duplex Plunger Stand and Plunger; Front and Lock Rod and Lugs; Horizontal Cranks and Jaws, no bolt-lock..... When ordering, send drawing of rail section.	58 50	.....	.....

STYLE "A" SWITCH AND LOCK MOVEMENT FITTINGS.

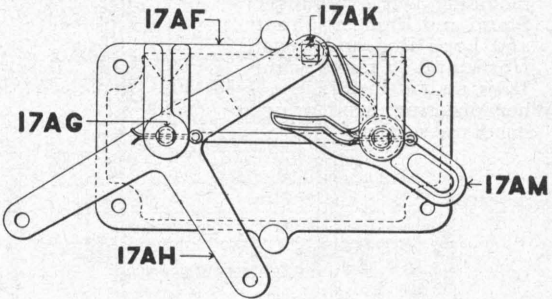

17AD

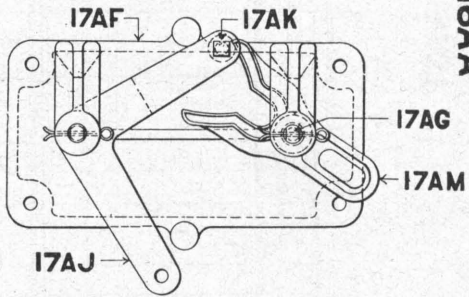

17AE

16AA

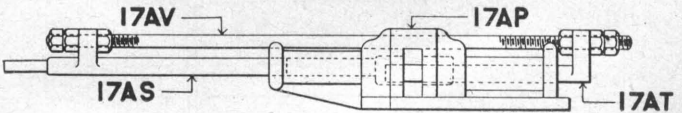

17AN

ORDER NO.	17. STYLE "A" SWITCH AND LOCK MOVEMENT AND FITTINGS.	LIST PRICE		WEIGHT	
				LBS	OZS
17 AD	Style "A" Switch and Lock Movement with T Crank and Escapement Jaw.....	6	80		
17 AE	Style "A" Switch and Lock Movement with L Crank and Escapement Jaw.....	6	45		
17 AF	Style "A" Switch and Lock Movement Stand.....	2	50		
17 AG	1" x 4" Pin.....		14		
17 AH	T Crank with Pin and Roller.	2	80		
17 AJ	L Crank with Pin and Roller.	2	50		
17 AK	$1\frac{5}{16}$ " x $1\frac{1}{2}$ " Steel Roller.....		12		
17 AL	$\frac{3}{4}$ " x $2\frac{1}{2}$ " Pin.....		10		
17 AM	Escapement Jaw.....		60		
17 AN	Duplex Plunger and Stand	7	00		
17 AP	Duplex Plunger Stand.....	1	65		
17 AR	No. 1 and 2 Duplex Plunger and Adjusting Rod.....	5	25		
17 AS	No. 1 Plunger.....	2	80		
17 AT	No. 2 Plunger.....	2	00		
17 AV	Adjusting Rod.....		50		



Style "E" Switch and Lock Movement Fittings.

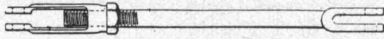

17BN

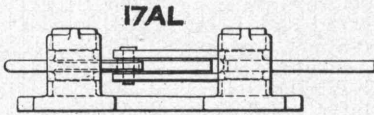

17AL

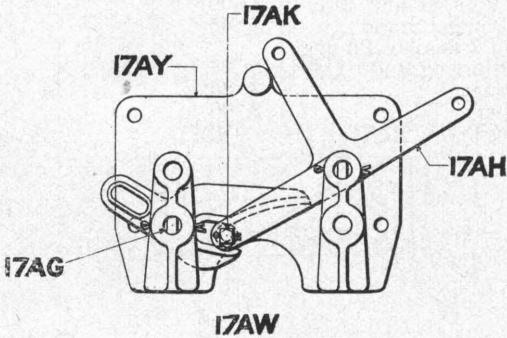

17AW

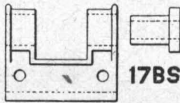

17BS

17BR

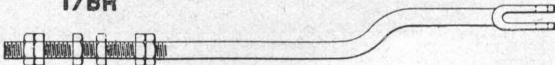

17BP



17BT

ORDER No.	17. STYLE "E" SWITCH AND LOCK MOVEMENT AND FITTINGS.	LIST PRICE		WEIGHT	
				LBS	OZS
17 AW	Style "E" Switch and Lock Movement, with "T" Crank and Escapement Jaw.....	8	30		
17 AX	Style "E" Switch and Lock Movement with "L" Crank and Escapement Jaw.....	7	95		
07 AY	Style "E" Switch and Lock Movement Stand.....	4	00		
17 AG	1" x 4" Pin.....		14		
17 AH	"T" Crank with Pin and Roller.....	2	80		
17 AJ	"L" Crank with Pin and Roller.....	2	50		
17 AK	1 1/8" x 1 1/2" Steel Roller.....		12		
17 AL	3/4" x 2 1/2" Pin.....		10		
17 AZ	Escapement Jaw.....		60		
17 BN	Lock Coupling.....	1	44		
17 BP	Switch Rod.....	3	00		
17 BR	Bridle.....		96		
17 BS	Sleeve.....		24		
17 BT	Switch Rod, tang end.....	1	80		

Switch and Lock Movement

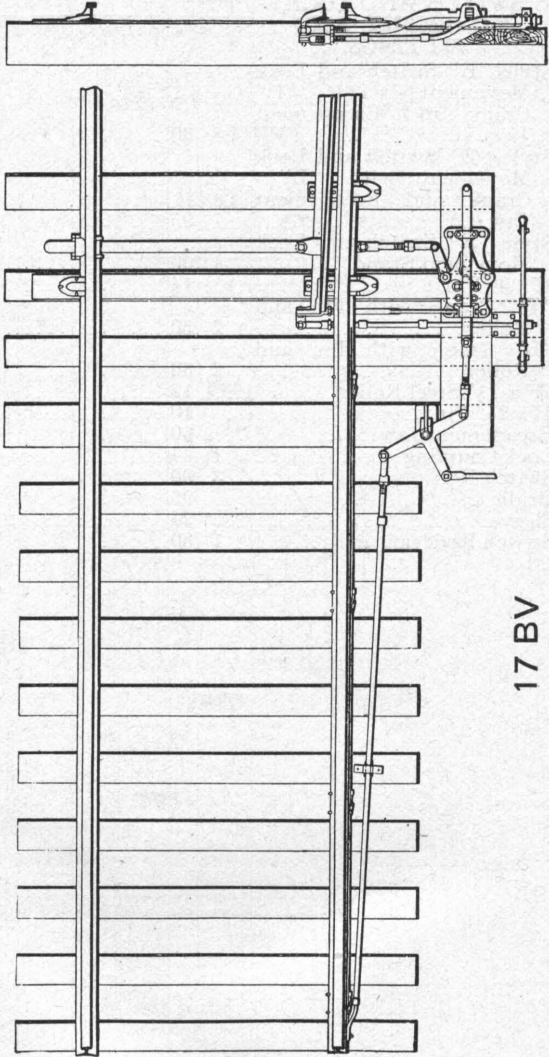

17 BV

ORDER No.	17. SWITCH AND LOCK MOVEMENTS.	LIST PRICE	WEIGHT	
			LBS	OZS
17 BV	No. 6 Switch and Lock Movement with Detector Bar complete for Deraill including Lock Rod and Lug, Horizontal crank, Jaws and 1-way Bolt-lock for pipe or wire. ....	58 25		

Switch and Lock Movement.

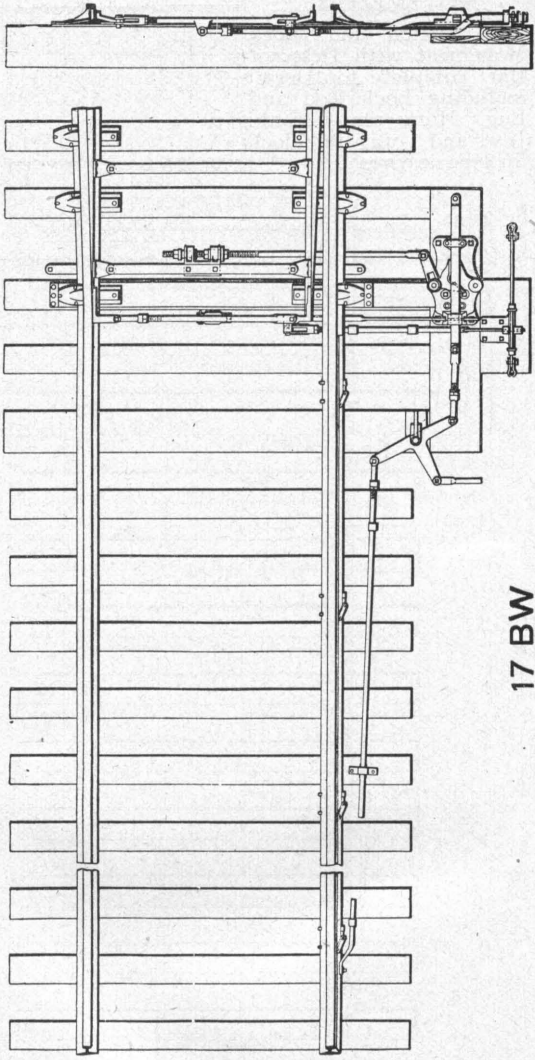

17 BW





Switch and Lock Movement.

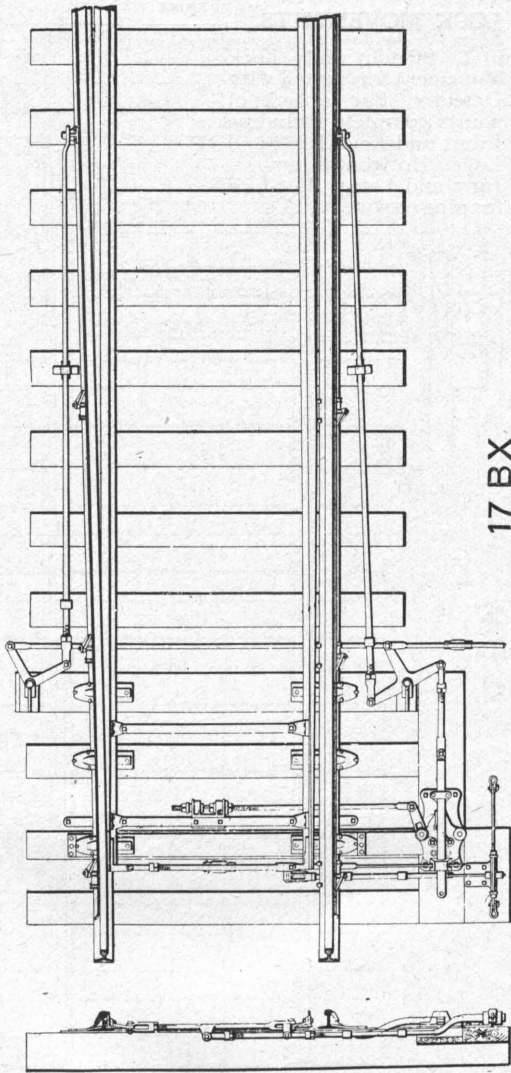

17 BX

ORDER No.	17. SWITCH AND LOCK MOVEMENTS.	LIST PRICE	WEIGHT	
			LBS	OZS
17 BX	No. 6 Switch and Lock Movement for Switch with Detector Bar in rear of points, complete including Front and Lock Rods and Lugs, Horizontal Cranks, Jaws and 1-way Bolt-lock for pipe or wire.....	96 25		



ORDER No.	17. No. 2 SWITCH AND LOCK MOVEMENT.	LIST PRICE	WEIGHT	
			LBS	OZS
17 DA	No. 2 Switch and Lock Movement, 8½" stroke, complete.....	7 60		
17 DB	Base.....	2 70		
17 DD	1" x 4½" Stud for Guide Roller.....	10		
17 DE	Cap for Guide Rollers.....	07		
17 DF	¼ x 1¾" split cotter for Studs.....	01		
17 DG	1" x 4" Stud for Guide Roller.....	10		
17 DH	1" Washer for Stud.....	02		
17 DJ	1¼ x 4" Stud for Escapement Crank.....	14		
17 DK	1¼" Washer for Stud.....	02		
17 DL	Guide Roller.....	10		
17 DM	Upper Slide Bar.....	42		
17 DN	Lower Slide Bar.....	42		
17 DP	Lug for Slide Bars.....	20		
17 DR	½" x 2¼" csk. head rivet for fastening lug to slide bars.....	01		
17 DS	Locking Plunger.....	16		
17 DT	½" x 1⅜" button-head rivet for fastening locking plunger to upper slide bar.....	01		
17 DV	½" x 3½" Bolt and 2 hex. nuts for fastening Lug and Locking Plunger to slide bars.....	04		
17 DW	Operating Roller.....	18		
17 DX	1" x 2⅜" Stud for Operating Roller.....	09		
17 DY	Escapement Crank.....	60		

## No. 5 Switch and Lock Movement.

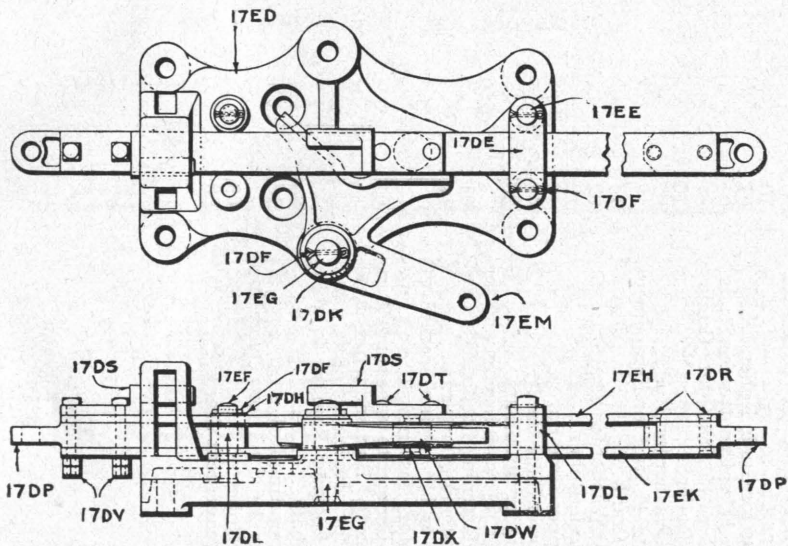

17EA

ORDER NO.	17. Nos. 5 AND 10 SWITCH AND LOCK MOVEMENT.	LIST PRICE	WEIGHT	
			LBS	OZS
17 EA	No. 5 Switch and Lock Movement, 8½" stroke, complete.....	9 25		
17 EB	No. 10 Switch and Lock Movement 12" stroke, complete.....	9 25		
17 ED	Base for No. 5 or 10.....	3 30		
17 EE	1" x 5" Stud for Guide Rollers.....	14		
17 DE	Cap for Guide Rollers.....	07		
17 DF	¼" x 1¾" Split cotter for Studs.....	01		
17 EF	1" x 4" stud for Guide Roller.....	12		
11 DH	1" Washer for Stud.....	01		
17 EG	1¼" x 5" Stud for Escapement Crank.....	16		
17 DK	1¼" Washer for Stud.....	02		
17 DL	Guide Rollers.....	16		
17 EH	Upper Slide Bar for No. 5....	48		
17 EJ	Upper Slide Bar for No. 10.....	52		
17 EK	Lower Slide Bar for No. 5....	48		
17 EL	Lower Slide Bar for No. 10..	52		
17 DP	Lug for Slide Bars.....	20		
17 DR	½" x 2¼" csk. hd. rivet for fastening Lug to Slide Bars.....	01		
17 DS	Locking plunger.....	16		
17 DT	½" x 1⅛" button head rivet for fastening Locking plunger to upper Slide Bar.....	01		
17 DV	½" x 3½" Bolt and 2 hex.nuts for fastening Locking plunger to Slide Bars.....	04		
17 DW	Operating Roller.....	21		
17 DX	1" x 2⅛" Stud for Operating Roller.....	09		
17 EM	Escapement Crank.....	72		



No. 6 Switch and Lock Movement.

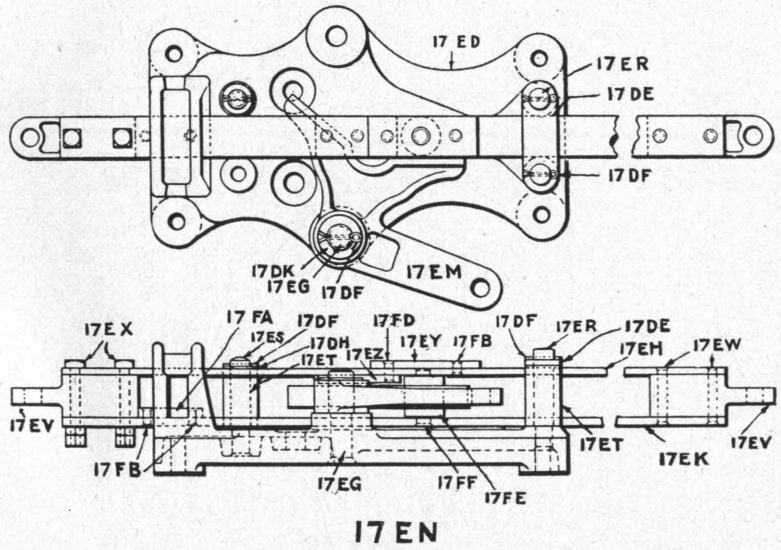

ORDER No.	17. Nos. 6 AND 7 SWITCH AND LOCK MOVEMENTS.	LIST PRICE		WEIGHT	
				LBS	OZS
17 EN	No. 6 Switch and Lock Movement, 8½" stroke complete.....	10	20		
17 EP	No. 7 Switch and Lock Movement, 12" stroke complete.....	10	20		
17 ED	Base for No. 6 or 7.....	3	60		
17 ER	1 x 5½" Stud for Guide Roller.....		14		
17 DE	Cap for Guide Rollers.....		07		
17 DF	¼" x 1¾" Split cotter for Studs.....		01		
17 ES	1" x 5½" Stud for Guide Roller.....		12		
17 DH	1" Washer for Stud.....		01		
17 EG	1¼" x 5" Stud for Escapement Crank.....		16		
17 DK	1¼" Washer for Stud.....		02		
17 ET	Guide Rollers.....		16		
17 EH	Upper Slide Bar for No. 6...		43		
17 EJ	Upper Slide Bar for No. 7.....		48		
17 EK	Lower Slide Bar for No. 6.....		43		
17 EL	Lower Slide Bar for No. 7.....		48		
17 EV	Lug for Slide Bars.....		20		
17 EW	½" x 3⅞" Rivet for fastening Lug to Slide Bars.....		01		
17 EX	½" x 4¼" Bolt and 2 hex. nuts for fastening Lug to Slide Bar.....		04		
17 EY	Slide Bar stop.....		09		
17 EZ	Upper Locking Dog.....		18		
17 FA	Lower Locking Dog.....		16		
17 FB	½" x 1" Rivet for fastening Slide Bar Stop and Locking Dogs to Slide Bars.....		01		
17 FD	½" x 1⅝" Rivet for fastening Slide Bar stop and Upper Locking Dog to Upper Slide Bar.....		01		
17 FE	Operating Roller.....		21		
17 FF	1" x 3" Stud for Operating Roller.....		09		
17 EM	Escapement Crank.....		72		

## No. 8 Switch and Lock Movement.

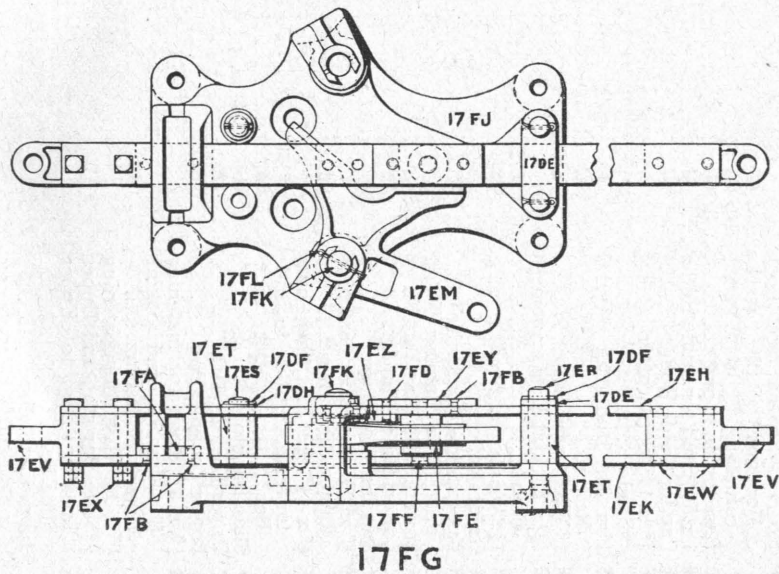

ORDER NO.	17. Nos. 8 AND 9 SWITCH AND LOCK MOVEMENTS.	LIST PRICE	WEIGHT	
			LBS	OZS
17 FG	No 8 Switch and Lock Movement, 8½" stroke, complete.....	9 75		
17 FH	No. 9 Switch and Lock Movement, 12" stroke, complete.....	9 75		
17 FJ	Base for No. 8 or 9.....	3 50		
17 ER	1" x 5½" Stud for Guide Roller.....	14		
17 DE	Cap for Guide Rollers.....	07		
17 DF	½" x 1¾" Split cotter for Studs.....	01		
17 ES	1" x 5½" Stud for Guide Roller.....	12		
17 DH	1" Washer for Stud.....	01		
17 FK	1¼" x 4 ¾" Pin for Escapement Crank.....	16		
17 FL	¼" x 3½" Split cotter for Pin..	01		
17 ET	Guide Rollers.....	16		
17 EH	Upper Slide Bar for No. 8.....	43		
17 EJ	Upper Slide Bar for No. 9.....	48		
17 EK	Lower Slide Bar for No. 8.....	43		
17 EL	Lower Slide Bar for No. 9.....	48		
17 EV	Lug for Slide Bars.....	20		
17 EW	½" 3⅛" Rivet for fastening Lug to Slide Bars.....	01		
17 EX	½" x 4¼" Bolt and 2 hex. nuts for fastening Lug to Slide Bars.....	04		
17 EY	Slide Bar Stop.....	09		
17 EZ	Upper Locking Dog.....	18		
17 FA	Lower Locking Dog.....	18		
17 FB	½" x 1" Rivet for fastening slide Bar Stop and Locking Dogs to Slide Bars....	01		
17 FD	½" x 1⅝" Rivet for fastening slide Bar Stop and Upper Locking Dog to Upper Slide Bar.....	01		
17 FE	Operating Roller.....	21		
17 FF	1" x 3" Stud for Operating Roller.....	09		
17 EM	Escapement Crank.....	72		

### No. 11 Switch and Lock Movement.

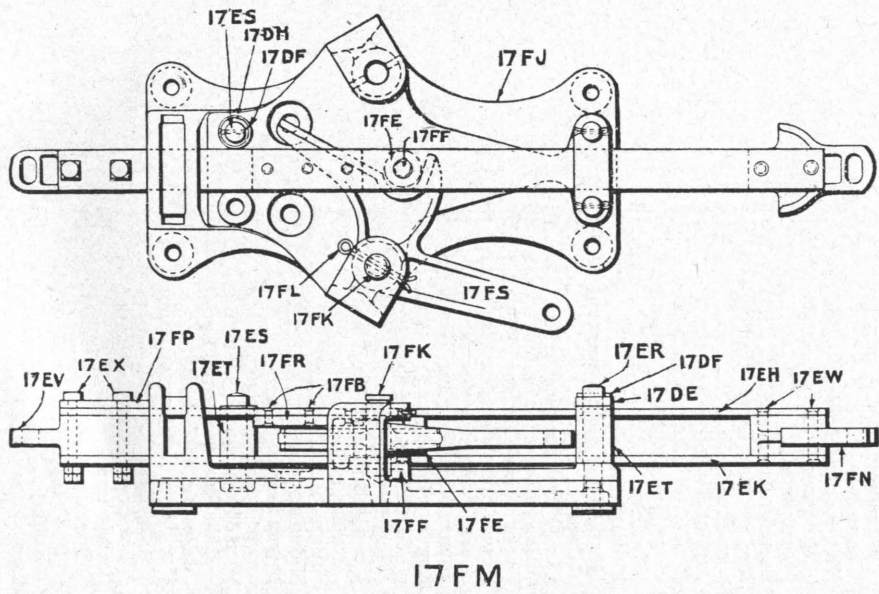

ORDER No.	17. No. 11. SWITCH AND LOCK MOVEMENT.	LIST PRICE		WEIGHT	
				LBS	OZS
17 FM	No. 11 Switch and Lock Movement, 8½" stroke, complete.....	10	80		
17 FJ	Base.....	4	50		
17 ER	1½" x 5½" Stud for Guide Roller.....		10		
17 DE	Cap for Guide Rollers.....		07		
17 DF	¼" x 1¾" Split cotter for Studs.....		01		
17 ES	1" x 5½" Stud for Guide Roller.....		10		
17 DH	1" Washer for Studs.....		02		
17 FK	1¼" x 4, 1⅜" Pin for Escapement Crank.....		21		
17 FL	¼" x 3½" Split cotter for Pin..		01		
17 ET	Guide Rollers.....		16		
17 EH	Upper Slide Bar.....		48		
17 EK	Lower Slide Bar.....		48		
17 EV	Lug for Slide Bars.....		32		
17 FN	Lug and Stop for Slide Bars.....		18		
17 EW	½" x 3⅞" Rivet for fastening Lug and Stop to Slide Bars.....		02		
17 EX	½" x 4¼" Bolt and 2 hex. nuts for fastening Lug and Slide Bar stop to Slide Bars.....		04		
17 FP	Slide Bar Stop.....		07		
17 FR	Locking Dog.....		30		
17 FB	½" x 1" Rivet for fastening Locking Dog to upper Slide Bar.....		01		
17 FE	Operating Roller.....		21		
17 FF	1" x 3" Stud for Operating Roller.....		09		
17 FS	Escapement Crank.....		72		



## No. 12 Switch and Lock Movement.

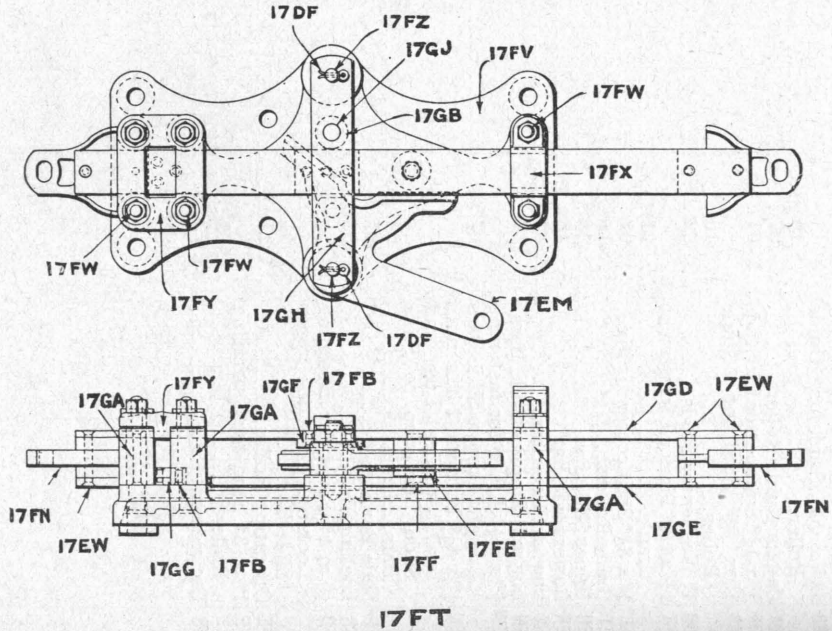

ORDER NO.	17. No. 12 SWITCH AND LOCK MOVEMENT.	LIST PRICE	WEIGHT	
			LBS	OZS
17 FT	No. 12 Switch and Lock Movement 8½" stroke, complete.....	11 90		
17 FV	Base.....	3 00		
17 FW	1" x 6" Stud with 5/8" hex. nut for Guide Roller.....	12		
17 FX	Cap for Guide Rollers.....	05		
17 DF	¼" x 1¾" Split cotter for Stud	01		
17 FY	Yoke for Guide Rollers and lock rod.....	18		
17 FZ	1¼" x 5¼" Stud for Escapement Crank.....	18		
17 GA	Guide Roller.....	20		
17 GB	Centre Guide Roller.....	20		
17 GD	Upper Slide Bar.....	52		
17 GE	Lower Slide Bar.....	52		
17 FN	Lug and Stop for Slide Bars	32		
17 EW	½" x 3½" Rivet for fastening Lug and Stop to Slide Bars	02		
17 GF	Upper Locking Dog.....	25		
17 GG	Lower Locking Dog.....	21		
17 FB	½" x 1" Rivet for fastening Locking Dogs, to Slide Bars.....	01		
17 FE	Operating Roller.....	21		
17 FF	1" x 3" Stud for Operating Roller.....	09		
17 GH	Cap for Crank and Centre Roller.....	28		
17 GJ	1" x 4½" Pin for centre Guide Roller.....	14		
17 EM	Escapement Crank.....	72		

### No. 13 Switch and Lock Movement.

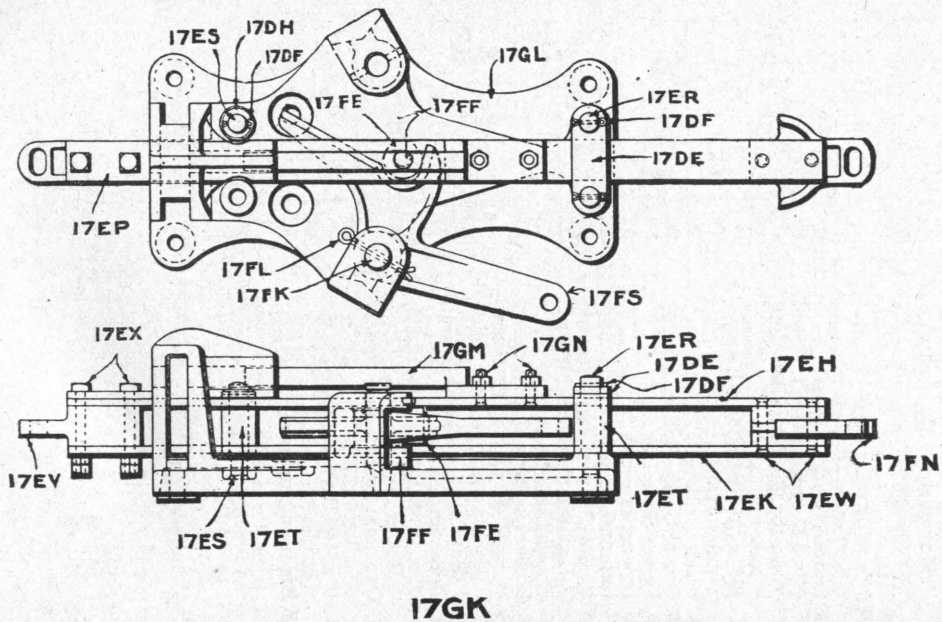

ORDER NO.	17. No. 13 SWITCH AND LOCK MOVEMENT.	LIST PRICE		WEIGHT	
				LBS	OZS
17 GK	No. 13 Switch and Lock Movement, 8½" stroke complete.....	11	00		
17 GL	Base.....	4	35		
17 ER	Stud for Guide Roller.....		12		
17 DE	Cap for Guide Roller.....		05		
17 DF	¼" x 1¾" Split cotter for Studs.....		01		
17 ES	1" x 5½" Stud for Guide Rollers.....		12		
17 DH	Washer for 1" studs.....		01		
17 FK	1¼" x 4¼" Pin for Escapement Crank.....		16		
17 FL	¼" x 3½" Split cotter for Pin.....		01		
17 ET	Guide Rollers.....		16		
17 EH	Upper Slide Bar.....		52		
17 EK	Lower Slide Bar.....		52		
17 EV	Lug for Slide Bars.....		32		
17 FN	Lug and Stop for Slide Bars.....		20		
17 EW	½" x 3½" Rivet for fastening Lug and Stop to Slide Bars.....		02		
17 EX	½" x 4¼" Bolt and 2 hex. nuts for fastening Lug and Slide Bar Stop to Slide Bars.....		05		
17 FP	Slide Bar Stop.....		07		
17 GM	Locking Plunger.....		43		
17 GN	½" x 1½" Bolt, csk. hd. with two hex nuts and split cotter for fastening Locking Plunger to Upper Slide Bar.....		04		
17 FE	Operating Roller.....		21		
17 FF	1" x 3" Stud for Operating Roller.....		09		
17 FS	Escapement Crank.....		72		

### No. 14 Switch and Lock Movement.

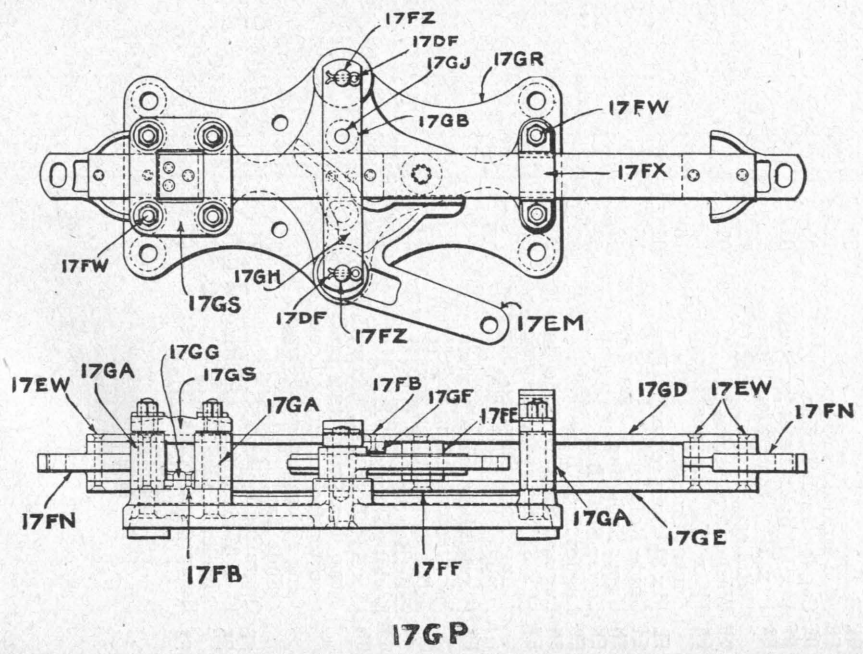

ORDER NO.	17. No. 14, SWITCH AND LOCK MOVEMENT.	LIST PRICE	WEIGHT	
			LBS	OZS
17 GP	No. 14 Switch and Lock Movement, 8½" stroke, complete.....	11 90		
17 GR	Base.....	3 00		
17 FW	1" x 6" Stud with ⅝" Hex. nut for Guide Roller.....	12		
17 FX	Cap for Guide Rollers.....	05		
17 DF	¼" x 1¾" Split cotter for Stud.....	01		
17 GS	Yoke for Guide Rollers and lock rod.....	20		
17 FZ	1¼" x 5¼" Stud for Escapement Crank.....	18		
17 GA	Guide Roller.....	20		
17 GB	Centre Guide Roller.....	20		
17 GD	Upper Slide Bar.....	52		
17 GE	Lower Slide Bar.....	52		
17 FN	Lug and Stop for Slide Bars.....	32		
17 EW	½" x 3⅝" Rivet for fastening Lug and Stop to Slide Bars.....	02		
17 FB	½" x 1" Rivet for fastening Locking Dogs to Slide Bars.....	01		
17 GF	Upper Locking Dog.....	25		
17 GG	Lower Locking Dog.....	21		
17 FE	Operating Roller.....	21		
17 FF	1" x 3" Stud for Operating Roller.....	09		
17 GH	Cap for Crank and Centre Guide Roller.....	28		
17 GJ	1" x 4⅝" Pin for Centre Guide Roller.....	14		
17 EM	Escapement Crank.....	72		



Front and Lock Rods, Style "1."

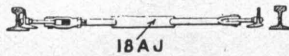
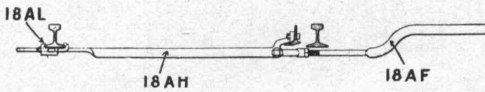
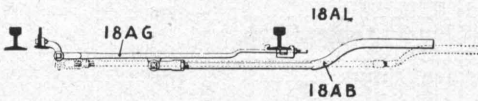
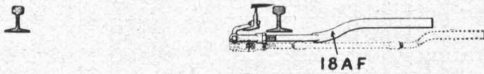
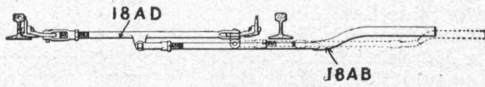
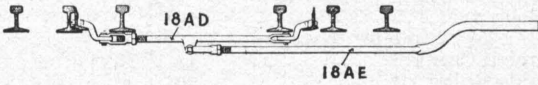
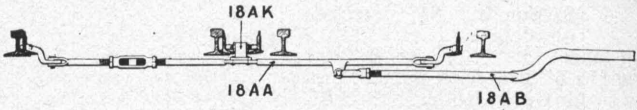

ORDER No.	18. FRONT AND LOCK RODS, STYLE "1,"	LIST PRICE	WEIGHT	
			LBS	OZS
18 AA	Front Rod for double slip complete, with point separator, no point Lugs.....	5 88		
18 AB	Lock Rod for double slip, switch or derail, complete.	2 50		
18 AD	Front Rod for movable point frog or switch complete, no point Lugs.....	2 60		
18 AE	Lock Rod for movable point frog complete.....	2 70		
18 AF	Lock Rod for derail, no point Lug.....	2 25		
18 AG	Front Rod for derail, centre connection, complete with Guide, no point Lug.....	2 85		
18 AH	Front Rod and point Lug combined for derail, end connection, complete with Guide.....	6 45		
18 AJ	Front and Lock Rod combined complete, no point Lugs.....	3 00		
18 AK	Point Separator complete with rivets.....	1 50		
18 AL	Derail Front Rod Guide plete.....	48		

Front and Lock Rods, Style "2."

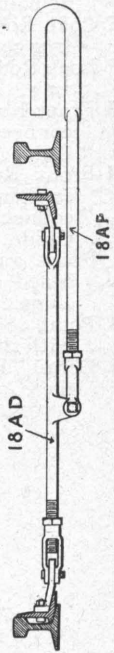
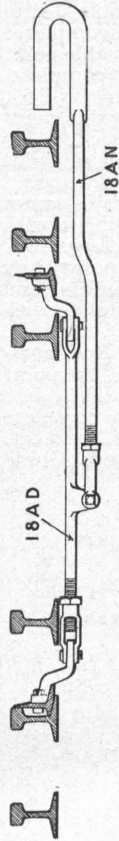
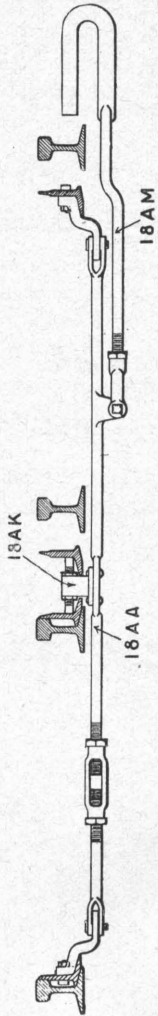

ORDER NO.	18. FRONT AND LOCK RODS, STYLE "2."	LIST PRICE	WEIGHT	
			LBS	OZS
18 AA	Front Rod for double slip complete with point separator, no point Lugs.....	5 88		
18 AD	Front Rod for movable point frog or switch, complete, no point Lugs.....	2 60		
18 AK	Point separator complete with rivets.....	1 50		
18 AM	Lock Rod for double slip complete.....	3 15		
18 AN	Lock Rod for movable point frog complete.....	3 35		
18 AP	Lock Rod for Switch complete.....	3 15		

## Front and Lock Rods, Style "3."

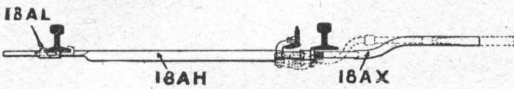
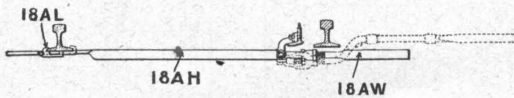
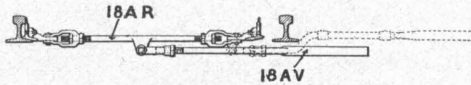
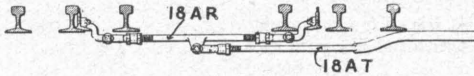
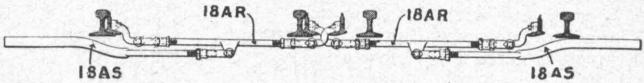

ORDER No.	18. FRONT AND LOCK RODS, STYLE "3."	LIST PRICE	WEIGHT	
			LBS	OZS
18 AL	Derail Front Rod Guide complete.....	48		
18 AR	Front Rod for double slip, movable point frog or Switch complete, no point Lugs.....	2 80		
18 AS	Lock Rod for double slip complete.....	2 25		
18 AT	Lock Rod for movable point frog or Switch operated by Switch and Lock Movement, complete.....	2 45		
18 AV	Lock Rod for Switch with Facing Point Lock, complete.....	1 85		
18 AH	Front Rod and Point Lug, combined for derail, end connection, complete with Guide.....	6 45		
18 AW	Lock Rod for derail with Facing Point Lock, complete.....	1 55		
18 AX	Lock Rod for derail operated by Switch and Lock Movement, complete.....	2 35		



Front and Lock Rods, Style "4"

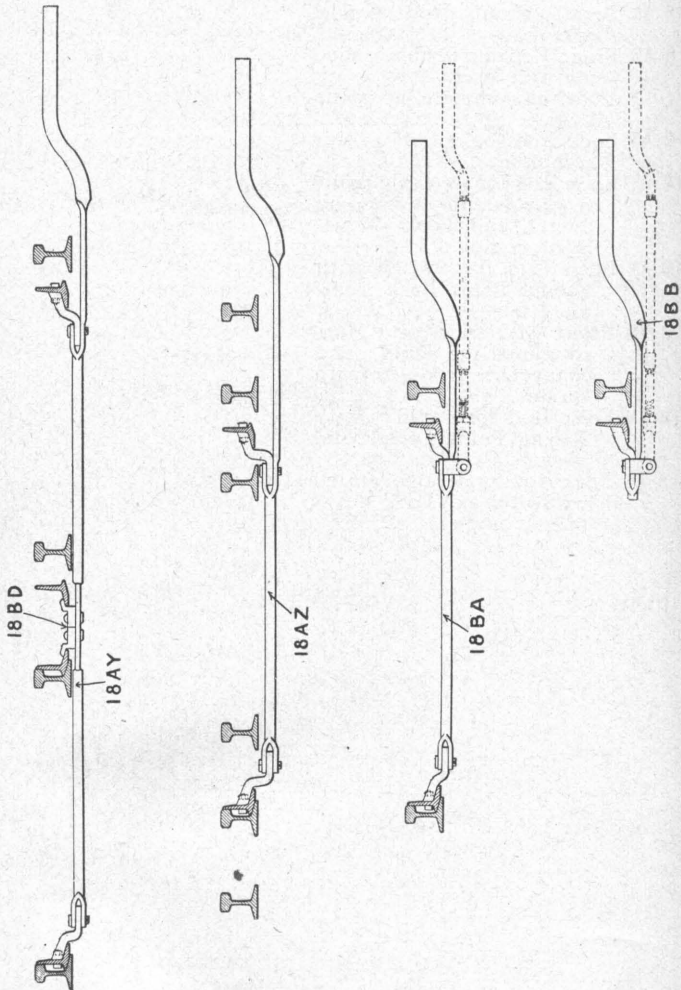

ORDER NO.	18. FRONT AND LOCK RODS, STYLE "4."	LIST PRICE	WEIGHT	
			LBS	OZS
18 AY	Front and Lock Rod combined for double slip, complete with point clamps, no point Lugs....	8 00		
18 AZ	Front and Lock Rod combined for movable point frog complete, no point Lugs.....	4 35		
18 BA	Front and Lock Rod combined for Switch complete, no point Lugs.....	4 05		
18 BB	Lock Rod for derail, complete, no point Lug.....	2 65		
18 BD	Point clamps complete with rivets.....	1 85		

Front and Lock Rods, Style "5."

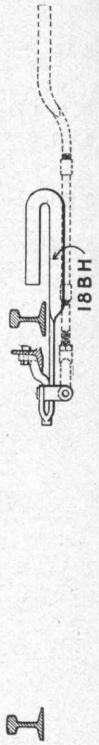
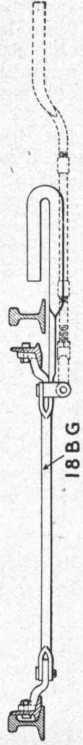
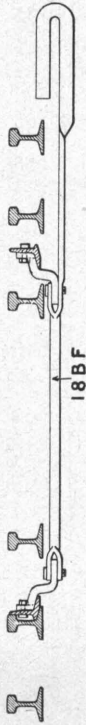
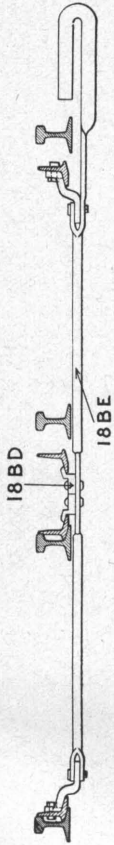

ORDER NO.	18. FRONT AND LOCK RODS, STYLE "5."	LIST PRICE	WEIGHT	
			LBS.	OZS
18 BD	Point clamps complete with rivets.....	1 85		
18 BE	Front and Lock Rod combined for double slip, complete with point clamps; no point Lugs.....	8 00		
18 BF	Front and Lock Rod combined for movable point frog, complete; no point Lugs.....	4 35		
18 BG	Front and Lock Rod combined for Switch, complete; no point Lugs.....	4 05		
18 BH	Lock Rod for derail, complete; no point Lug.....	2 65		

## Front and Lock Rods, Style "6."

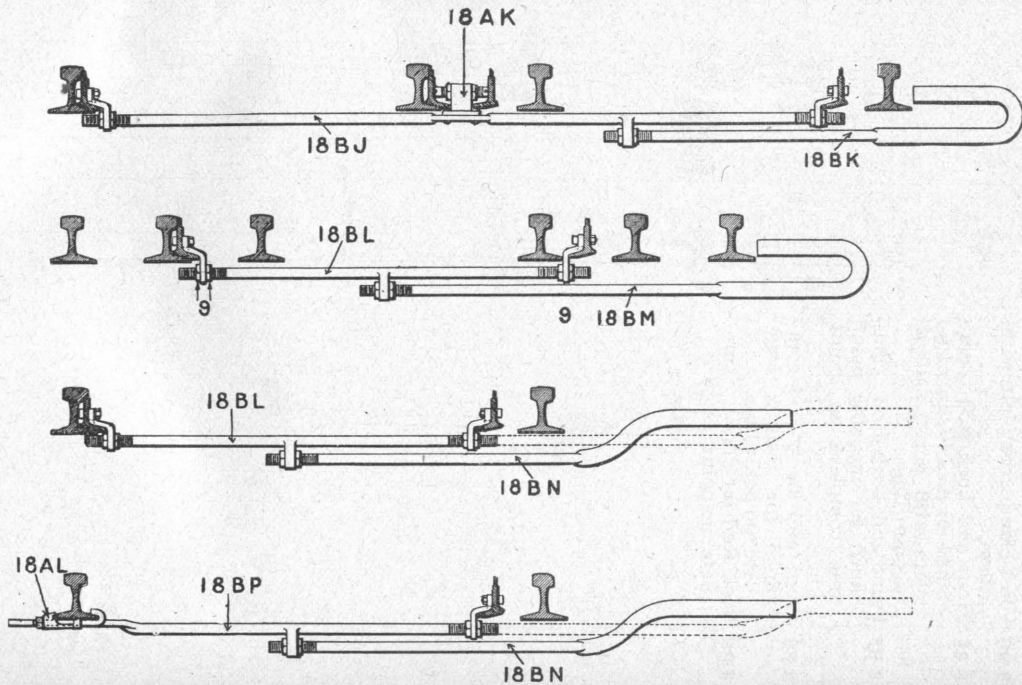

ORDER No.	18. FRONT AND LOCK RODS, STYLE "6."	LIST PRICE		WEIGHT	
				LBS	OZS
18 AK	Point separator complete with rivets.....	1	50		
18 AL	Deraill Front Rod Guide complete.....		48		
18 BJ	Front Rod for double slip, complete with point separator; no point Lugs.....	6	65		
18 BK	Lock Rod for double slip, complete.....	2	15		
18 BL	Front Rod for movable point frog or Switch, complete; no point Lugs.....	3	65		
18 BM	Lock Rod for movable point frog, complete.....	2	15		
18 BN	Lock Rod for Switch or derail, complete.....	2	15		
18 BP	Front Rod for derail complete with Guide, no point Lug.....	3	40		



Front and Lock Rods, Style "7."

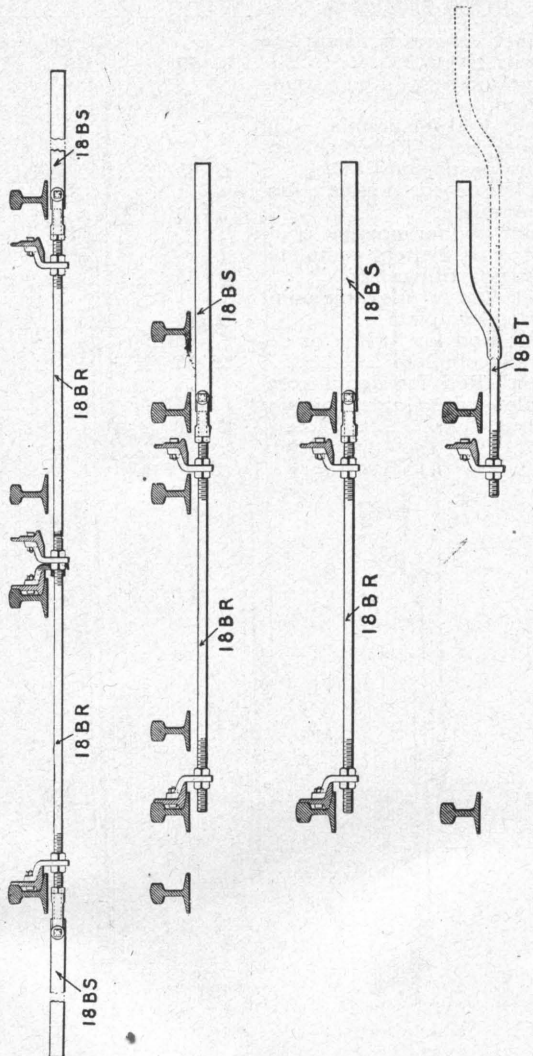

ORDER No.	18. FRONT AND LOCK RODS, STYLE "7."	LIST PRICE	WEIGHT	
			LBS	OZS
18 BR	Front Rod for double slip, movable point frog or Switch, complete; no point Lugs.....	2 00	.....	.....
18 BS	Lock Rod for double slip, movable point frog or Switch, complete.....	1 05	.....	.....
18 BT	Lock Rod for derail, com- plete; no point Lug.....	2 35	.....	.....

### Point Lugs

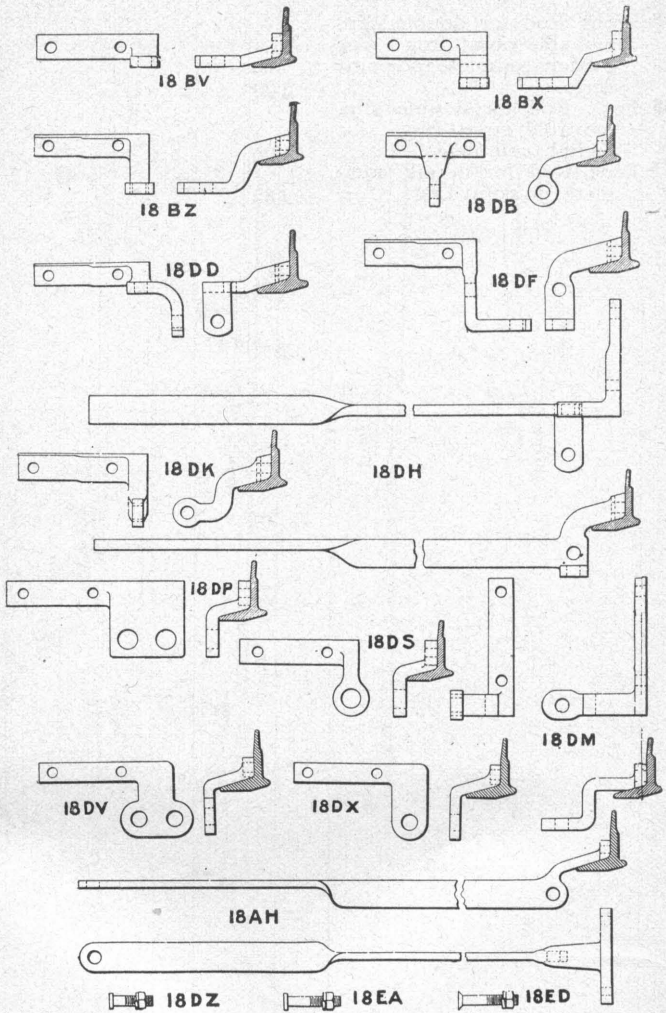

ORDER NO.	18. POINT LUGS	LIST PRICE	WEIGHT	
			LBS	OZS
18 BV	Point Lug, right-hand for Switch Style "1".....	63		
18 BW	Point Lug, left-hand for Switch Style "1".....	63		
18 BX	Point Lug, right-hand for Switch Style "2".....	1 30		
18 BY	Point Lug, left-hand for Switch Style "2".....	-1 30		
18 BZ	Point Lug, right-hand for double slip or movable point frog Style "3".....	1 30		
18 DA	Point Lug, left-hand for double slip or movable point frog Style "3".....	1 30		
18 DB	Point Lug right or left-hand for derail lock-rod Style "4".....	1 30		
18 DD	Point Lug, right-hand for Switch with independent Bolt-lock connection Style "5".....	2 60		
18 DE	Point Lug, left-hand for Switch with independent Bolt-lock connection Style "5".....	2 60		
18 DF	Point Lug right-hand for derail with independent Bolt-lock connection Style "6".....	2 70		
18 DG	Point Lug, left-hand for derail with independent Bolt-lock connection Style "6".....	2 70		
18 DH	Front Rod and Point Lug combined, right-hand for derail with independent Bolt-lock connection Style "7".....	7 65		
18 DJ	Front Rod and Point Lug combined, left-hand for derail with independent Bolt-lock connection Style "7".....	7 65		
18 DK	Point Lug, right-hand for movable point frog Style "8".....	1 60		
18 DL	Point Lug, left-hand for movable point frog Style "8".....	1 60		

ORDER NO.	18. POINT LUGS—Cont.	LIST PRICE	WEIGHT	
			LBS	OZS
18 DM	Point Lug, right-hand for re-enforced Switch Style "9".	1 35		
18 DN	Point Lug, left-hand for re-enforced Switch Style "9".	1 35		
18 DP	Point Lug, right-hand for Switch or derail with independent Bolt-lock connection Style "10".	3 00		
18 DR	Point Lug, left-hand for Switch or derail with independent Bolt-lock connection Style 10.	00		
18 DS	Point Lug, right-hand for Switch or derail Style "11".	2 61		
18 DT	Point Lug, left-hand for Switch or derail Style "11".	2 61		
18 DV	Point Lug, right-hand for Switch or derail with independent Bolt-lock connection Style "12".	2 85		
18 DW	Point Lug, left-hand for Switch or derail with independent bolt-lock connection, Style "12".	2 85		
18 DX	Point Lug, right-hand for movable point frog, switch or derail Style "13".	2 00		
18 DY	Point Lug, left-hand for movable point frog, Switch or derail, Style "13".	2 00		
18 AH	Front Rod and point Lug combined, either right or left-hand for derail, Style "14".	5 80		
18 DZ	$\frac{5}{8}$ " x $2\frac{3}{8}$ " Bolt, flat head and nut for fastening Lugs to Switch point.	07		
18 EA	$\frac{5}{8}$ " x $3\frac{3}{8}$ " Bolt, flat head and nut, for fastening Lugs to re-enforced Switch point.	08		
18 EB	$\frac{3}{4}$ " x $3\frac{1}{2}$ " Bolt, flat head and nut, for fastening Lugs to re-enforced Switch point.	08		
18 ED	$\frac{3}{4}$ " x $3\frac{1}{4}$ " Bolt, csk. head and nut for fastening Lug to Switch point (used with Style "3" Front Rods).	08		





### Detector Bars and Fittings

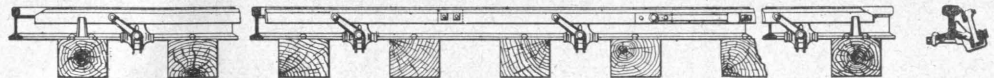

19AA



19AF



19AG



16AK

19AD

19AH

19AE

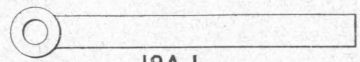

19AJ

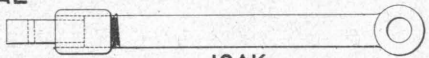

19AK

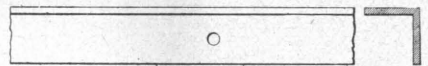

19AV

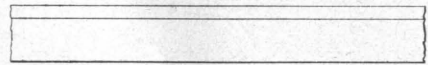

19AW



19BB



19AT



19AP



19AR



19BE



19BF

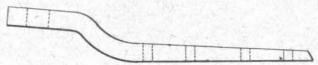

19AL

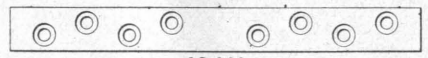
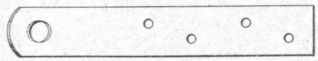

19AN



19AM

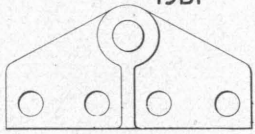

19AS

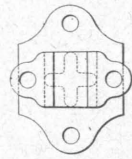

19AZ

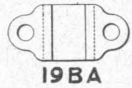

19BA

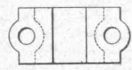

19BD

ORDER NO.	19. DETECTOR BARS AND FITTINGS.	LIST PRICE	WEIGHT.	
			LBS	OZS
19 AA	50 ft. Detector Bar and fourteen Rail Clips complete	26 00		
19 AB	50 ft. Detector Bar in three pieces.....	5 75		
19 AD	$\frac{3}{4}$ " x $1\frac{3}{4}$ " Bolts with Csk. Heads and Nuts.....	07		
19 AE	Detector Bar Stud.....	07		
19 AF	Driving Plate and Stud.....	45		
19 AG	Driving Plate.....	25		
19 AH	Driving Plate Stud.....	10		
16 AK	$\frac{5}{8}$ " x 1" Rivet.....	01		
19 AJ	Driving Eye, solid end.....	50		
19 AK	Driving Eye tang end.....	69		
19 AL	Special Driving Plate.....	60		
19 AM	Wrot Driving and splice plate with Stud.....	1 00		
19 AN	Wrot Splice Plate.....	36		
19 AP	$\frac{1}{2}$ " x $1\frac{1}{4}$ " Csk. head rivet for Wrot Splice Plates.....	01		
19 AR	$\frac{1}{2}$ " x $1\frac{1}{2}$ " Csk. head Bolt and nut for Wrot Splice Plates.	03		
19 AS	Mall Driving and Splice Plate with Stud.....	45		
19 AT	$\frac{1}{2}$ " x $1\frac{1}{4}$ " Button head rivet for Mall Splice Plate.....	01		
19 AV	$\frac{1}{4}$ " x $2\frac{1}{4}$ x $2\frac{1}{4}$ " Angle Detector Bar for inside the rail, per ft.....	21		
19 AW	$\frac{3}{8}$ " x $2\frac{1}{4}$ " Detector Bar per ft	10		
19 AX	$\frac{7}{16}$ " x $2\frac{1}{4}$ " Detector Bar, per ft	12		
19 AY	$\frac{1}{2}$ " x $2\frac{1}{4}$ " Detector Bar, per ft.	14		
19 AZ	Pipe Guide Stand.....	21		
19 BA	Pipe Guide Cap.....	09		
19 BB	$\frac{1}{2}$ " x $1\frac{3}{4}$ " Bolt and nut for pipe Guide.....	03		
19 BD	Pipe clamp.....	09		
19 BE	$\frac{1}{2}$ " x $1\frac{1}{2}$ " Bolt and nut for pipe clamp.....	03		
19 BF	Detector Bar Spring.....	27		

Rail Clips, Style 7 and 8.

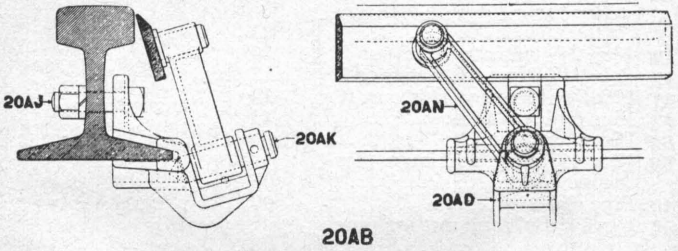
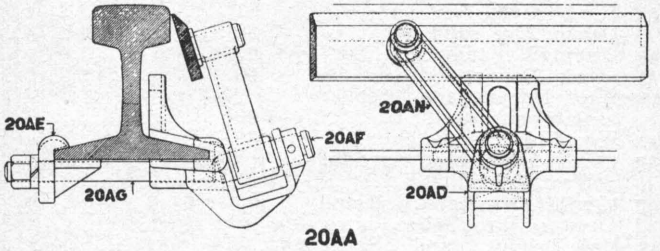

ORDER NO.	20. RAIL CLIPS, STYLE 7 AND 8.	LIST PRICE	WEIGHT	
			LBS	OZS
20 AA	Rail-clip, 1" pin, complete for front of Switch.....	1 10		
20 AB	Rail-clip, 1" pin, complete for rear of Switch.....	1 10		
20 AD	Rail-clip only.....	58		
20 AE	Half-clip, only.....	09		
20 AF	1" x 3 <sup>1</sup> / <sub>8</sub> " Pin.....	09		
20 AG	<sup>5</sup> / <sub>8</sub> " x 6" "T" Bolt, nut and lock washer.....	09		
20 AH	<sup>5</sup> / <sub>8</sub> " x 7" "T" Bolt, nut and lock washer.....	09		
20 AJ	<sup>5</sup> / <sub>8</sub> " x 2 <sup>1</sup> / <sub>2</sub> " Bolt, nut and lock washer.....	06		
20 AK	Radial arm for 4" to 4 <sup>1</sup> / <sub>4</sub> " Rail, 1" pin.....	25		
20 AL	Radial arm for 4 <sup>1</sup> / <sub>4</sub> " to 4 <sup>1</sup> / <sub>2</sub> " Rail, 1" Pin.....	25		
20 AM	Radial arm for 4 <sup>1</sup> / <sub>2</sub> " to 4 <sup>3</sup> / <sub>4</sub> " Rail, 1" Pin.....	25		
20 AN	Radial arm for 4 <sup>3</sup> / <sub>4</sub> " to 5" Rail, 1" Pin.....	25		
20 AP	Radial arm for 5" to 5 <sup>3</sup> / <sub>8</sub> " Rail, 1" pin.....	25		
20 AR	Radial arm for 5 <sup>3</sup> / <sub>8</sub> " to 5 <sup>3</sup> / <sub>4</sub> " Rail, 1" Pin.....	25		
20 AS	Radial arm for 5 <sup>3</sup> / <sub>4</sub> " to 6" Rail, 1" Pin.....	25		

### Detector Bar Stop and Guide

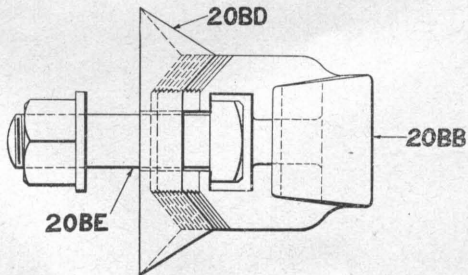
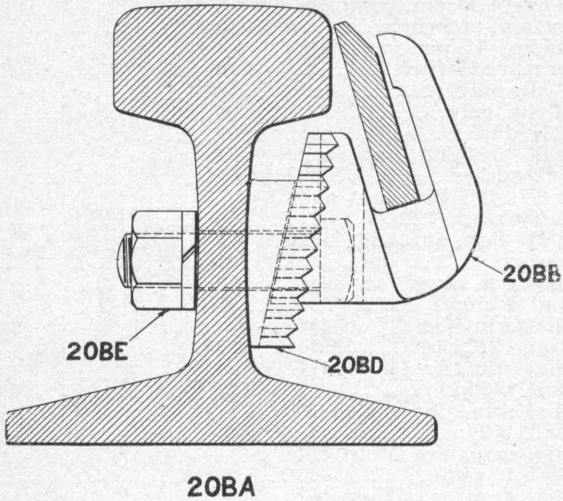

ORDER No.	20. DETECTOR BAR STOP AND GUIDE.	LIST PRICE	WEIGHT	
			LBS	OZS
20 BA	Adjustable Detector Bar Stop and Guide complete	30		
20 BB	Adjustable Stop and Guide	15		
20 BD	Adjustable Washer	09		
20 BE	$\frac{5}{8}$ " x 2 $\frac{1}{4}$ " Special Bolt, nut and spring washer	06		



Rail Clips, Styles 11 and 12.

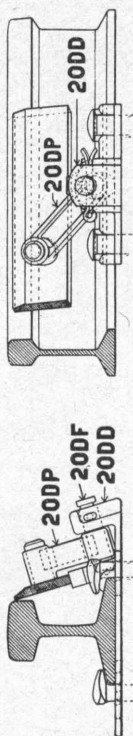

20DA

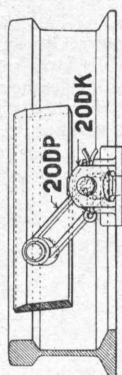

20DH

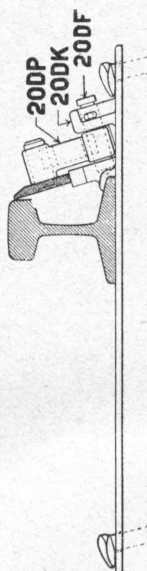
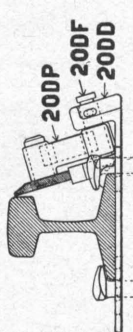

ORDER NO.	20. RAIL CLIPS. Style 11 Rail Clips for Front of Switch.	LIST PRICE	WEIGHT	
			LBS	OZS
20 DA	Rail Clip complete for 4" to 4 $\frac{3}{4}$ " Rail.....			
20 DB	Rail Clip complete for 5" to 6" Rail.....			
20 DD	Rail Clip only, for 4" to 4 $\frac{3}{4}$ " Rail.....			
20 DE	Rail Clip only, for 5" to 6" Rail.....			
20 DF	1" x 3 $\frac{3}{8}$ " Pin.....			
	<b>Style 12 Rail Clips for Rear of Switch.</b>			
20 DH	Rail Clip complete.....			
20 DK	Rail Clip, only.....			
20 DF	1" x 3 $\frac{3}{8}$ " Pin.....			
	<b>Radial Arms.</b>			
20 DM	Radial Arm for 4" Rail, 1" pin.....			
20 DN	Radial Arm for 4 $\frac{1}{4}$ " to 4 $\frac{1}{2}$ " Rail, 1" Pin.....			
20 DP	Radial Arm for 4 $\frac{3}{4}$ " to 5" Rail, 1" Pin.....			
20 DR	Radial Arm for 5 $\frac{1}{4}$ " to 5 $\frac{1}{2}$ " Rail, 1" Pin.....			
20 DS	Radial Arm for 6" Rail, 1" Pin.....			

Rail Clips.

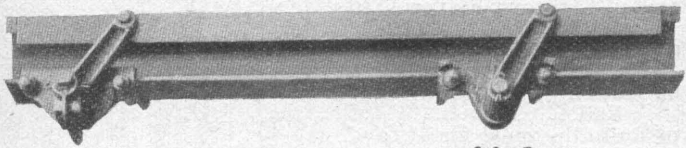

20EA

20EB



20EK

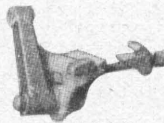

20ER



20EP



20FK



20EY



20EZ

ORDER No.	20. RAIL CLIPS —Continued	LIST PRICE	WEIGHT	
			LBS.	OZS
20 EA	Hambay Clip with Jaw support complete.....	1 45		
20 EB	Hambay Clip with Stud support complete.....	1 15		
20 ED	Hambay Clip with Jaw support only.....	90		
20 EE	Hambay Clip with Stud support only.....	65		
20 EF	1" x 4 1/8" Pin and cotter for clip with Jaw support.....	09		
20 EG	1" x 4 3/8" Stud and cotter for Clip with Stud support.....	09		
20 EH	5/8" Hook Bolt, nut and Spring Washer.....	09		
20 EJ	Radial arm (give distance between centres, or size of rail for which it is required).....	27		
20 EK	C. R. I. & P. Style Clip complete.....	1 00		
20 EL	C. R. I. & P. Style Clip with Stud, only.....	48		
20 EM	1" x 4 1/2" Stud and cotter for C. R. I. & P. Clip.....	12		
20 EH	5/8" Hook Bolt, nut and Spring Washer.....	09		
20 EN	Radial arm (give distance between centres, or size of rail for which it is required).....	27		
20 EP	National Style Clip with Jaw support complete....	1 30		
20 ER	National Style Clip with Stud support complete....	1 15		
20 ES	National Style Clip with Jaw support only.....	75		
20 ET	National Style Clip with Stud support only.....	60		
20 EV	1" x 3 3/4" pin and cotter for Clip with Jaw support....	09		
20 EW	1" x 4 1/8" Stud and cotter for Clip with Stud support....	09		
20 EX	Radial arm (give distance between centres, or size of rail for which it is required).....	27		
20 EY	Short motion Plate Clip complete.....	1 35		

ORDER NO.	20. RAIL CLIPS Continued	LIST PRICE		WEIGHT	
				LBS.	OZS
20 EZ	Long motion Plate Clip complete.....	1	40		
20 FA	Bracket for motion Plate clip (give size of rail for which it is required).....		40		
20 FB	Guide cap for bracket.....		20		
20 FD	Spacing ferrule.....		06		
20 FE	Roller.....		12		
20 FF	$\frac{3}{4}$ " x $3\frac{1}{2}$ " Bolt with hex. nut and cotter for fastening cap to bracket.....		12		
20 FG	$\frac{3}{4}$ " x $2\frac{1}{4}$ " Bolt with hex. nut and Spring washer for fastening bracket to rail....		12		
20 FH	Short motion Plate.....		30		
20 FJ	Long motion Plate.....		35		
20 FK	Adjustable Detector Bar Stop with Hook Bolt complete.....		55		
20 FL	Rail bracket for adjustable Stop.....		20		
20 FM	Stop piece for adjustable Stop.....		25		
20 EH	$\frac{5}{8}$ " Hook Bolt, nut and Spring washer.....		09		





Rail Braces

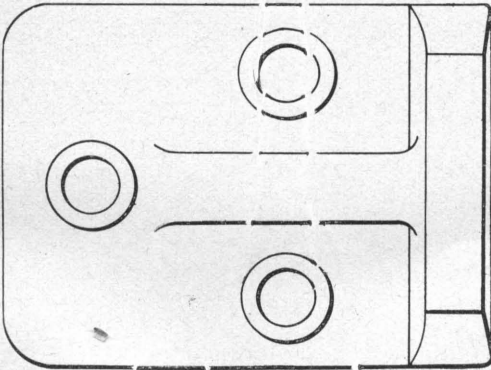
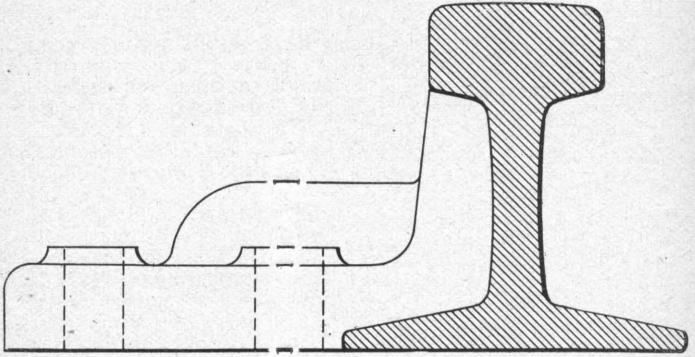

2IAF

ORDER NO.	21. RAIL BRACES	LIST PRICE	WEIGHT	
			LBS	OZS
21 AA	No. 1 Rail Brace for 4 " Rail	28		
21 AB	No. 2 " " " 4 1/4 " Rail	31		
21 AD	No. 3 " " " 4 1/2 " "	34		
21 AE	No. 4 " " " 4 3/4 " "	37		
21 AF	No. 5 " " " 5 " "	40		
21 AG	No. 6 " " " 5 1/4 " "	43		
21 AH	No. 7 " " " 5 1/2 " "	46		
21 AJ	No. 8 " " " 5 3/4 " "	49		
21 AK	No. 9 " " " 6 " "	52		

BOLT LOCKS.

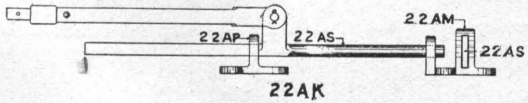
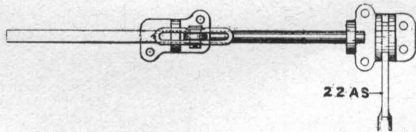
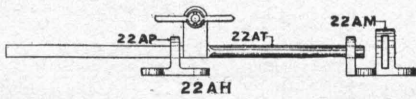
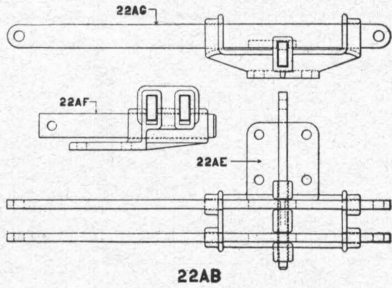
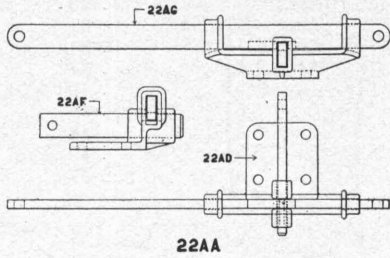

ORDER NO.	22. BOLT LOCKS.	LIST PRICE		WEIGHT	
				LBS	OZ <sup>s</sup>
22 AA	1-way Bolt Lock complete for Wire or Pipe Connections.....	3	50		
22 AB	2-way Bolt Lock complete for Wire or Pipe Connections.....	5	50		
22 AD	1-way Stand.....	1	50		
22 AE	2-way Stand.....	2	30		
22 AF	Switch Slide.....		85		
22 AG	Signal Slide.....		85		
22 AH	1-way Johnson Style Bolt-lock for wire complete....	4	00		
22 AJ	2-way Johnson Style Bolt-lock for wire complete....	6	25		
22 AK	1-way Johnson Style Bolt-lock for pipe complete; no Jaws.....	4	50		
22 AL	2-way Johnson Style Bolt-lock for pipe complete; no Jaws.....	6	75		
22 AM	1-way Johnson Style Lock Stand.....	1	00		
22 AN	2-way Johnson Style Lock Stand.....	1	50		
22 AP	1-way Johnson Style Guide Stand.....		50		
22 AR	2-way Johnson Style Guide Stand.....		80		
22 AS	Switch Slide Bar.....		85		
22 AT	Signal Slide Bar.....		85		

Draw Bridge Locks.

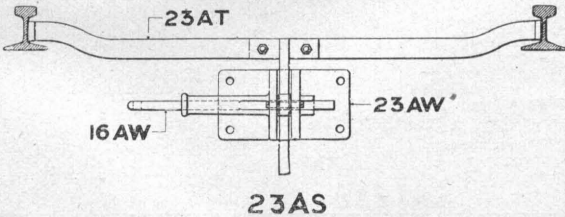
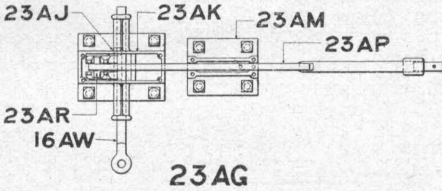
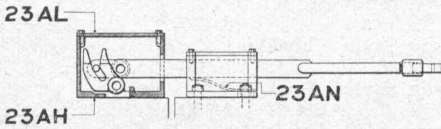
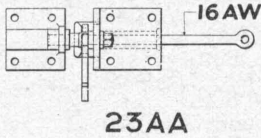
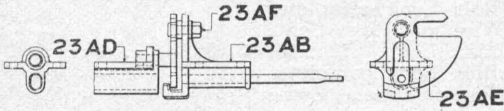

ORDER No.	23. DRAW BRIDGE LOCKS.	LIST PRICE	WEIGHT	
			LBS	OZS
23 AA	Tumbler Draw Bridge Lock complete.....	7 80		
23 AB	Tumbler Stand.....	3 20		
23 AD	Releasing Stand and Stud....	2 00		
23 AE	Tumbler.....	90		
23 AF	Stud Bolt and Nut.....	20		
16 AW	Steel Plunger.....	45		
23 AG	Draw Bridge Bolt Lock complete .....	14 40		
23 AH	Escapement Jaw.....			
23 AJ	$\frac{7}{8}$ " x $5\frac{1}{4}$ " Pin.....			
23 AK	Plunger Box.....			
23 AL	Plunger Box Cover.....			
23 AM	Tappet Guide and Spring.....			
23 AN	$\frac{1}{4}$ " x $\frac{3}{4}$ " x 8" Spring.....			
23 AP	Tappet with Stud.....			
23 AR	$\frac{7}{8}$ " x $2\frac{3}{4}$ " Stud.....			
16 AW	Steel Plunger.....	45		
23 AS	Lift Rail Bridge Lock complete .....	8 50		
23 AT	Front Rod and Lock Tappet.....	6 30		
23 AW	Plunger Casting.....	1 50		
16 AW	Steel Plunger.....	45		



## Bridge Couplers

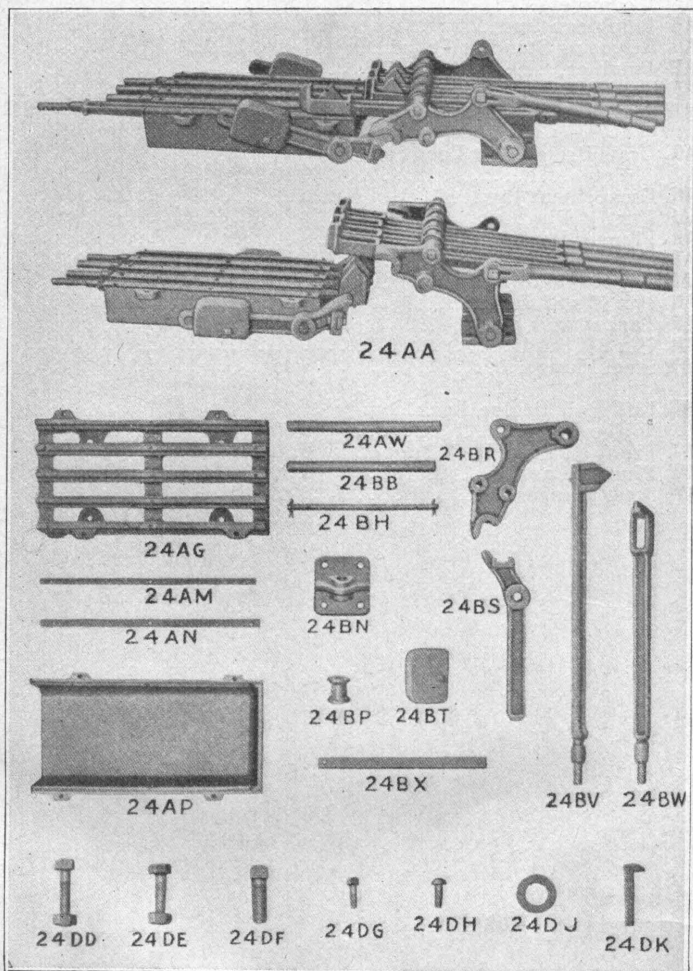

ORDER NO.	24. BRIDGE COUPLERS	LIST PRICE		WEIGHT	
				LBS	OZS
24 AA	4-way Bridge Coupler complete with Slotted Jaw . . . . .	34	50		
24 AB	6-way Bridge Coupler complete with Slotted Jaw . . . . .	43	65		
24 AD	8-way Bridge Coupler complete with Slotted Jaw . . . . .	53	75		
24 AE	10-way Bridge Coupler complete with Slotted Jaw . . . . .	62	75		
24 AF	13-way Bridge Coupler complete with Slotted Jaw . . . . .	76	00		
24 AG	Base for 4-way Bridge Coupler . . . . .	3	80		
24 AH	Base for 6-way Bridge Coupler . . . . .	5	60		
24 AJ	Base for 8-way Bridge Coupler . . . . .	7	35		
24 AK	Base for 10-way Bridge Coupler . . . . .	8	30		
24 AL	Base for 13-way Bridge Coupler . . . . .	10	00		
24 AM	Side strip for Base . . . . .		07		
24 AN	Middle strip for Base . . . . .		07		
24 AP	Cover for 4-way Bridge Coupler . . . . .	2	70		
24 AR	Cover for 6-way Bridge Coupler . . . . .	4	60		
24 AS	Cover for 8-way Bridge Coupler . . . . .	5	25		
24 AT	Cover for 10-way Bridge Coupler . . . . .	6	20		
24 AV	Cover for 13-way Bridge Coupler . . . . .	8	10		
24 AW	Crank shaft for 4-way . . . . .		65		
24 AX	“ “ “ 6-way . . . . .		95		
24 AY	“ “ “ 8-way . . . . .	1	10		
24 AZ	“ “ “ 10-way . . . . .	1	25		
24 BA	“ “ “ 13-way . . . . .	1	50		
24 BB	Counterweight shaft for 4-way . . . . .		65		
24 BD	Counterweight shaft for 6-way . . . . .		95		
24 BE	Counterweight shaft for 8-way . . . . .	1	10		
24 BF	Counterweight shaft for 10-way . . . . .	1	25		

ORDER NO.	24. BRIDGE COUPLERS Continued.	LIST PRICE		WEIGHT	
				LBS	OZS
24 BG	Counterweight shaft for 13-way.....	1	50		
24 BH	Guide Roller shaft for 4-way.....		18		
24 BJ	Guide Roller shaft for 6-way.....		21		
24 BK	Guide Roller shaft for 8-way.....		24		
24 BL	Guide Roller shaft for 10-way.....		27		
24 BM	Guide Roller shaft for 13-way.....		36		
24 BN	Bearing for Crank Shaft, 2 required for each shaft....		75		
24 BP	Guide Roller.....		15		
24 BR	Engaging Crank.....	1	25		
24 BS	Counterweight Locking Arm.....		85		
24 BT	Counterweight with Set screws.....		35		
24 BV	Hook Slide Bar, tang end....	1	00		
24 BW	Engaging Bar, tang end....		95		
24 BX	4-way Locking Bar.....		30		
24 BY	6-way " ".....		55		
24 BZ	8-way " ".....		60		
24 DA	10-way " ".....		70		
24 DB	13-way " ".....		85		
24 DD	$\frac{3}{8}$ " x $1\frac{3}{4}$ " Bolt and hex. nut for Locking Bar.....		02		
24 DE	$\frac{3}{8}$ " x $1\frac{1}{2}$ " Bolt and hex. nut for fastening cover to base.....		02		
24 DF	$\frac{1}{2}$ " x $1\frac{1}{2}$ " Set screw for fastening counterweight to Locking Arm.....		04		
24 DG	$\frac{1}{4}$ " x $\frac{3}{4}$ " Cap screw for fastening middle strip to base....		02		
24 DH	$\frac{1}{4}$ " x $\frac{3}{4}$ " Machine Screw for fastening side strip to base.....		02		
24 DJ	Special $\frac{3}{4}$ " washer for Guide Roller Shaft.....		01		
24 DK	Key for Crank or Counterweight Shaft.....		18		



SCOTCH BLOCK.

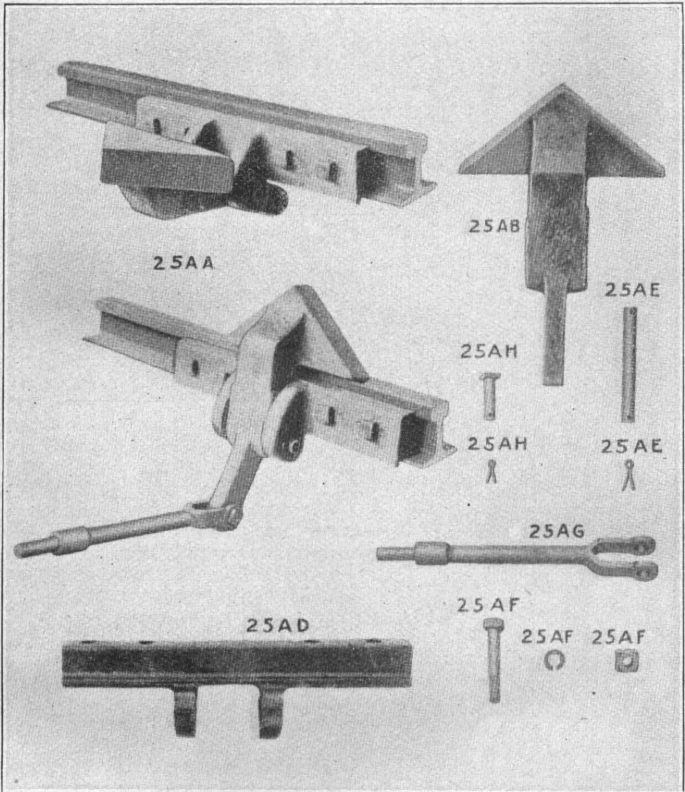

ORDER NO.	25. SCOTCH BLOCK.	LIST PRICE		WEIGHT	
				LBS	OZS
25 AA	Scotch Block complete, no Jaw.....	21	50		
25 AB	Scotch Block.....	10	50		
25 AD	Scotch Block Bracket.....	10	25		
25 AE	1" x 8" Shaft and Cotters....		20		
25 AF	3/8" x 5" Bolt with Square nut and Spring Washer for fastening bracket to rail....		14		
25 AG	Special 1 1/4" Jaw, tang end...	1	20		
25 AH	7/8" x 3" Pin and Cotter for Jaw.....		07		
	When ordering send tracing of Rail Section				



## Jaws

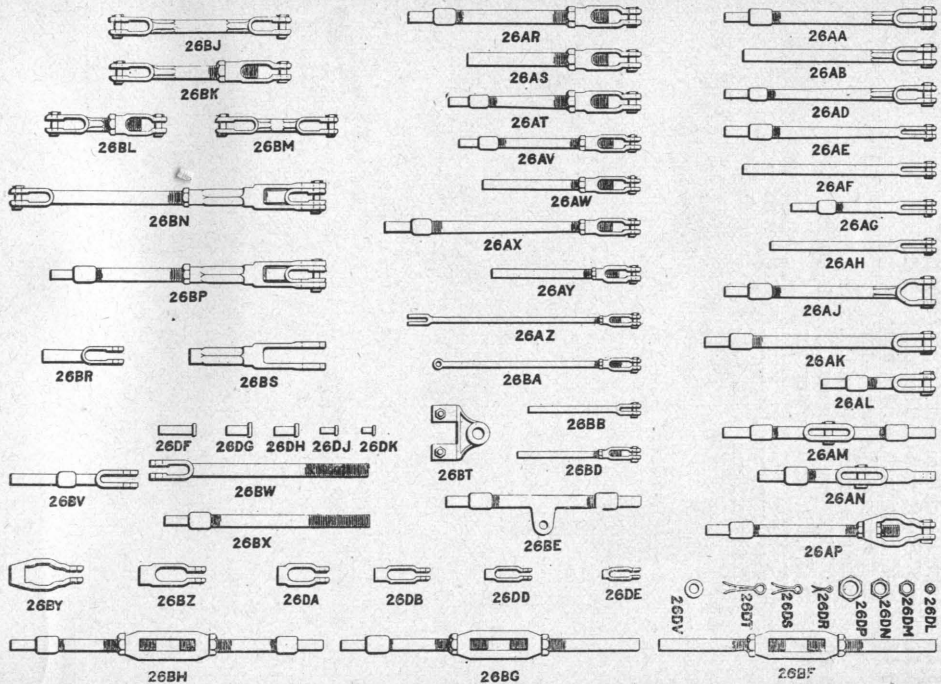

ORDER No.	26	JAWS	PRICE LIST	WEIGHT	
				LBS	OZS
26 AA	1 1/4"	Plain Jaw, tanged for 1" pipe, complete with Pin and Cotter.....	80		
26 AB	1 1/4"	Plain Jaw, Stub end complete with Pin and Cotter.....	60		
26 AD	1 1/4"	Plain Jaw, tanged for 3/4" pipe, complete with Pin and Cotter.....	1 10		
26 AE	1"	Plain Jaw, tanged for 1" pipe, complete with Pin and Cotter.....	1 10		
26 AF	1"	Plain Jaw, Stub end complete, with Pin and Cotter.....	42		
26 AG	1"	Plain Jaw, tanged for 3/4" pipe, complete with Pin and Cotter.....	60		
26 AH	3/4"	Plain Jaw, Stub end, complete with Pin and Cotter.....	60		
26 AJ	1 1/4"	Wide Jaw, tanged for 1" pipe, complete with Pin and Cotter.....	1 05		
26 AK	1 1/4"	Slotted Plain Jaw, tanged for 1" pipe, complete with Pin and Cotter.....	1 45		
26 AL	1 1/4"	Plain Malleable Jaw, tanged for 1" pipe, complete with Pin and Cotter.....	65		
26 AM	1 1/4"	Double Jaw, tanged for 1" pipe, complete with Pin and Cotter.....	1 85		
26 AN	1 1/4"	Double Jaw, tanged one end for 1" pipe and eye at other end, complete with Pin and Cotter.....	2 05		
26 AP	1 1/4"	Special Adjustable Jaw, tanged for 1" pipe complete with Pin and Cotter.....	1 25		
26 AR	1 1/4"	Screw Jaw, tanged for 1" pipe, complete with Pin and Cotter.....	1 05		
26 AS	1 1/4"	Screw Jaw, Stub end, complete with Pin and Cotter.....	90		
26 AT	1 1/4"	Screw Jaw, tanged for 3/4" pipe complete with Pin and Cotter.....	1 35		
26 AV	1"	Screw Jaw, tanged for 3/4" pipe, complete with Pin and Cotter.....	75		

ORDER No.	26. JAWS—Cont.	LIST PRICE	WEIGHT	
			LBS	OZS
26 AW	1" Screw Jaw, Stub end, complete with Pin and Cotter.....	55		
26 AX	1" Wrot Screw Jaw, tanged for 1" pipe, complete with Pin and Cotter.....	2 70		
26 AY	¾" Screw Jaw, Stub end, complete with Pin and Cotter.....	36		
26 AZ	½" Connecting Link with Plain Jaw at one end and Screw Jaw at the other end, complete with Pin and Cotter.....	80		
26 BA	½" Connecting Link, with Screw Jaw at one end and eye at other end, complete with Pin and Cotter.....	37		
26 BB	½" Plain Jaw, Stub end, complete with Pin and Cotter.....	54		
26 BD	½" Screw Jaw, Stub end, complete with Pin and Cotter.....	32		
26 BE	1¼" Wrot Lug, tanged for 1" pipe.....	1 10		
26 BF	1¼" Point Adjusting Screw, Stub ends.....	1 80		
26 BG	1¼" Point Adjusting Screw, tanged one end for 1" pipe, Stub at other end.....	1 95		
26 BH	1¼" Point Adjusting Screw tanged both ends for 1" Pipe.....	2 15		
26 BJ	1¼" Plain Link, 18" centres, complete with Pin and Cotters.....	1 55		
26 BK	1¼" Adjustable Link, 18" centres, complete with Pins and Cotters.....	1 40		
26 BL	1¼" Adjustable Link, 12" centres, complete with Pins and Cotters.....	1 40		
26 BM	1¼" Plain Link, 12" centres, complete with Pin and Cotters.....	1 45		
26 BN	1¼" Gain Stroke Jaw, with Plain Jaw at one end, complete with Pin and Cotter.....	2 50		

ORDER No.	26. JAWS—Cont.	LIST PRICE		WEIGHT	
				LBS	OZS
26 BP	1 1/4" Gain Stroke Jaw, tanged for 1" pipe, complete with Pin and Cotter.....	2	25		
25 BR	1 1/4" Plain Jaw, Stub end.....		60		
26 BS	1 1/4" Special Screw Jaw for Gain Stroke Jaw.....		60		
26 BT	Clamp Pipe Lug for 1" pipe..		75		
26 BV	1 1/4" Mall. Jaw for 26-AL.....		50		
26 BW	1 1/4" Plain Jaw, Threaded end		65		
26 BX	1 1/4" Threaded Rod, tanged for 1" pipe.....		50		
26 BY	1 1/4" Mall. Jaw for 26-AP.....		36		
26 BZ	1 1/4" Mall. Jaw for 26-AR, etc		30		
26 DA	1 1/4" Mall. Jaw for 26-BL.....		30		
26 DB	1" Mall. Jaw.....		25		
26 DD	3/4" Mall. Jaw.....		20		
26 DE	3/4" Mall. Jaw.....		15		
26 DF	7/8" x 3 7/8" Pin, Square Head...		18		
26 DG	1 5/8" x 2 3/8" Pin, Square Head..		07		
26 DH	1 7/8" x 2 3/8" Pin, Square Head...		06		
26 DJ	1 5/8" x 1 5/8" Pin, Round Head...		06		
26 DK	1 5/8" x 1 1/4" Pin, Round Head...		06		
26 DL	1 1/2" Hexagon Nut.....		02		
26 DM	1 1/2" Hexagon Nut.....		04		
26 DN	1" Hexagon Nut.....		07		
26 DP	1 1/4" Hexagon Nut (thin).....		07		
26 DR	1 1/8" x 3/4" Cotter.....		01		
26 DS	1 1/8" x 1" Cotter.....		01		
26 DT	1 1/8" x 1 1/2" Cotter.....		01		
26 DV	1 1/8" Washer.....		01		

PIPE CARRIERS.

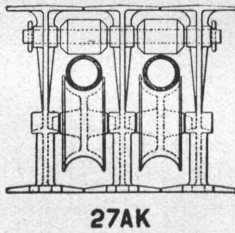
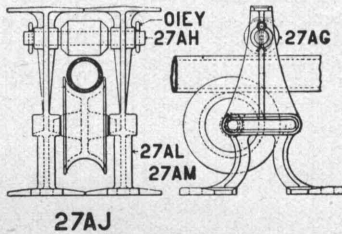
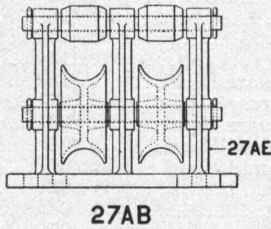
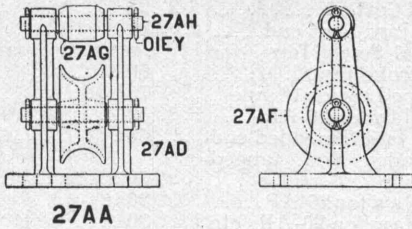

ORDER No.	27. PIPE CARRIERS.	LIST PRICE	WEIGHT	
			LBS	OZS
27 AA	1-way Plain Pipe Carrier complete.....	40		
27 AB	2-way Plain Pipe Carrier complete.....	60		
27 AD	1-way Plain Pipe Carrier Stand.....	23		
27 AE	2-way Plain Pipe Carrier Stand.....	34		
27 AF	Bottom Roller.....	07		
27 AG	Top Roller.....	02		
27 AH	½" Pin for number of ways required, 1-way.....	04		
	Each additional way.....	01		
01 EY	⅛" x 1¼" Split Cotter.....	01		
	NOTE.—Any number of ways can be made up from the 1 and 2-way.			
27 AJ	1-way Anti-friction Pipe Carrier complete, Style "5".....	43		
27 AK	2-way Anti-friction Pipe Carrier complete, Style "5".....	70		
27 AL	Pipe Carrier Side.....	14		
27 AM	Bottom Roller.....	07		
27 AG	Top Roller.....	02		
27 AH	½" Pin for number of ways required, 1-way.....	04		
	Each additional way.....	01		
01 EY	⅛" x 1¼" Split Cotter.....	01		



Pipe Carriers.

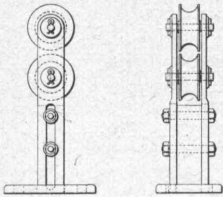

27BA

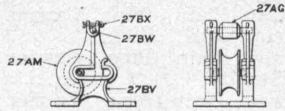

27BT



27BY

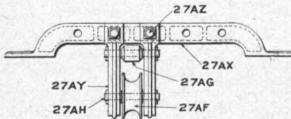

27AS

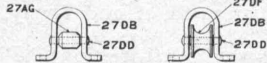

27DA

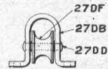

27DE

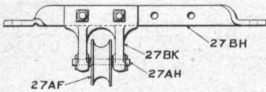

27BB

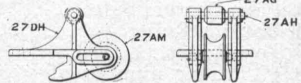

27DG

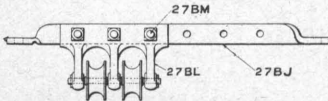

27BD

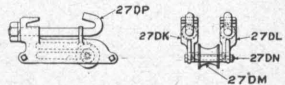

27DJ

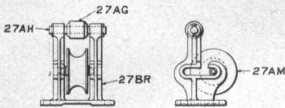

27BN

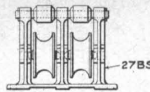

27BP

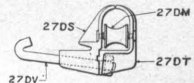

27DR

ORDER No.	27. PIPE CARRIERS. —Continued.	LIST PRICE		WEIGHT	
				LBS	OZS
27 AS	1-way Pipe Carrier between Ties, complete Style "8" ..	1	10		
27 AT	2-way Pipe Carrier between Ties, complete Style "8" ..	1	33		
27 AV	3-way Pipe Carrier between Ties, complete Style "8" ..	1	56		
27 AW	4-way Pipe Carrier between Ties, complete Style "8" ..	1	79		
27 AX	Bearer, Style "8" .....		75		
27 AY	Carrier Side, Style "8" .....		12		
27 AZ	$\frac{3}{8}$ " x $1\frac{1}{2}$ " Bolt and Nut .....		03		
27 AF	Bottom Roller .....		07		
27 AG	Top Roller .....		02		
27 AH	$\frac{1}{2}$ " Pin .....		04		
01 EY	$\frac{1}{8}$ " x $1\frac{1}{4}$ " Split Cotter .....		01		
27 BA	Adjustable Pipe Guide for Down Rods .....	1	36		
27 BB	1-way Pipe Carrier between Ties complete Style "7" ..	1	17		
27 BD	2-way Pipe Carrier between Ties, complete Style "7" ..	1	42		
27 BE	3-way Pipe Carrier between Ties, complete Style "7" ..	1	67		
27 BF	4-way Pipe Carrier between Ties, complete Style "7" ..	1	92		
27 BG	5-way Pipe Carrier between Ties, complete Style "7" ..	2	17		
27 BH	1 to 3-way Bearer, Style "7" ..		72		
27 BJ	1 to 5-way Bearer, Style "7" ..		77		
27 BK	1-way Stand Style "7" .....		23		
27 BL	2-way Stand Style "7" .....		34		
27 BM	$\frac{1}{2}$ " x 2" Bolt and Nut .....		04		
27 BN	1-way Anti-friction Pipe Carrier, complete Style "2" ..		40		
27 BP	2-way Anti-friction Pipe Carrier, complete Style "2" ..		61		
27 BR	1-way Stand Style "2" .....		23		
27 BS	2-way Stand Style "2" .....		34		
27 BT	1-way Universal Anti-fric- tion Pipe Carrier, complete Style "3" .....		32		
27 BV	Pipe Carrier Side, Style "3" ..		10		
27 BW	Universal Bridging Pin .....		03		
27 BX	$\frac{3}{16}$ " x $1\frac{1}{2}$ " Cotter Pin .....		01		
27 BY	Pipe Carrier for fixing on Ties, large Roller .....		23		
27 BZ	Wrot Stand for 27-BY .....		16		
27 DA	Pipe Carrier for fixing on Ties, small Roller .....		20		

ORDER No.	27. PIPE CARRIERS. —Continued.	LIST PRICE	WEIGHT	
			LBS	OZS
27 DB	Wrot Stand for 27-DA and 27-DE.....	14		
27 DD	Pin for 27-DA and 27-DE....	04		
27 DE	Pipe Carrier for fixing on Ties, medium Roller.....	23		
27 DF	Roller for 27-DE.....	04		
27 DG	Pipe Carrier for fixing on side of Ties.....	43		
27 DH	Stand for 27-DG.....	23		
27 DJ	Pipe Carrier for fixing to rail for transverse connections... ..	82		
27 DK	Left-hand Stand for 27-DJ....	21		
27 DL	Right-hand Stand for 27-DJ....	21		
27 DM	Roller for 27-DJ.....	03		
27 DN	$\frac{3}{8}$ " x 4" Bolt and Nut for 27-DJ.....	04		
27 DP	Hook Bolt, Nut and Lock Washer for 27-DJ.....	07		
27 DR	Pipe Carrier for fixing to rail for connections parallel to track.....	46		
27 DS	Left-hand Stand for 27-DR..	20		
27 DT	Right-hand Stand for 27-DR....	16		
27 DV	Hook Bolt, Nut and Lock Washer for 27 -DR.....	07		



Pipe and Fittings.



28AA



28AD

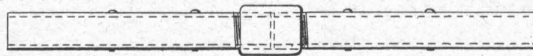

28AF



28AH

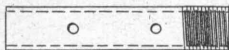

28AK

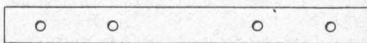

28AM

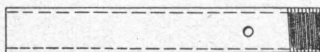

28AN

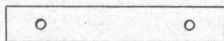

28AR

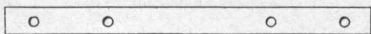

28AS



28AT

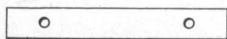

28AW



28AX



28AZ



28BA



28BD



28BB

ORDER NO.	28 PIPE AND FITTINGS.	LIST PRICE	WEIGHT	
			LBS	OZS
28 AA	1" Black Pipe with 10" Plug and 3" Coupling .....			
28 AB	1" Galvanized Pipe with 10" Plug and 3" Coupling .....			
28 AD	1" Black Pipe with 6" Plug and 2 1/4" Coupling .....			
28 AE	1" Galvanized Pipe with 6" Plug and 2 1/4" Coupling .....			
28 AF	3/4" Black Pipe with 10" Plug and 1 5/8" Coupling .....			
28 AG	3/4" Galvanized Pipe with 10" Plug and 1 5/8" Coupling .....			
28 AH	3/4" Black Pipe with 6" Plug and 1 5/8" Coupling .....			
28 AJ	3/4" Galvanized Pipe with 6" Plug and 1 5/8" Coupling .....			
28 AK	1" Black Pipe drilled for 2 rivets .....			
28 AL	1" Galvanized Pipe drilled for 2 rivets .....			
28 AM	10" Plug for 1" Pipe, 4 holes .....	10		
28 AN	1" Black Pipe drilled for 1 rivet .....			
28 AP	1" Galvanized Pipe drilled for 1 rivet .....			
28 AR	6" Plug for 1" Pipe, 2 holes .....	06		
28 AS	10" Plug for 3/4" Pipe, 4 holes .....	07		
28 AT	3/4" Black Pipe drilled for 2 rivets .....			
28 AV	3/4" Galvanized Pipe drilled for 2 rivets .....			
28 AW	6" Plug for 3/4" Pipe, 2 holes .....	05		
28 AX	3/4" Black Pipe drilled for 1 rivet .....			
28 AY	3/4" Galvanized Pipe drilled for 1 rivet .....			
28 AZ	3" Coupling for 1" Pipe .....	16		
28 BA	2 1/4" Coupling for 1" Pipe .....	14		
28 BB	1 5/8" Coupling for 3/4" Pipe .....	10		
28 BD	1/4 x 1 9/16" Rivet .....	01		



VERTICAL WHEELS.

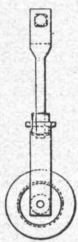

35AA

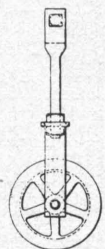

35AB

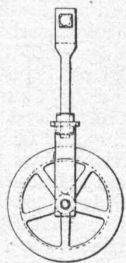

35AD

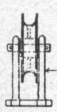

35AS

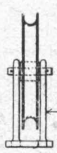

35AT

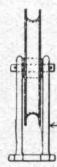

35AV



35AY



35AX

35AW

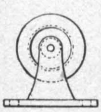

35AE

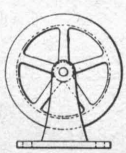

35AF

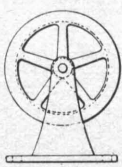

35AG

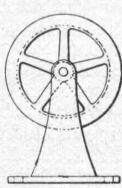

35AH

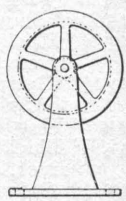

35AJ



35AZ



35BA



35BB

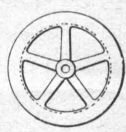

35BD

ORDER No.	35. VERTICAL WHEELS.	LIST PRICE.						WEIGHT	
								LBS	OZS
35 AA	6" Gain Stroke Wheel.....	1 36							
35 AB	8" Gain Stroke Wheel.....	1 43							
35 AD	10" Gain Stroke Wheel.....	1 58							
35 AE	No. 0 1-way 4" Vertical Wheel 5" high.....	63							
35 AF	No. 1 1-way 6" Vertical Wheel 5" high.....	68							
35 AG	No. 0 1-way 8" Vertical Wheel 5" high.....	75							
35 AH	No. 1 1-way 8" Vertical Wheel 6½" high.....	86							
35 AJ	No. 1 1-way 10" Vertical Wheel 6½" high.....	1 20							
35 AK	No. 2 1-way 8" Vertical Wheel 8" high.....	99							
35 AL	No. 2 1-way 10" Vertical Wheel 8" high.....	1 31							
35 AM	No. 3 1-way 8" Vertical Wheel 9½" high.....	1 27							
35 AN	No. 3 1-way 10" Vertical Wheel 9½" high.....	1 42							
35 AP	No. 4 1-way 8" Vertical Wheel 11" high.....	1 38							
35 AR	No. 4 1-way 10" Vertical Wheel 11" high.....	1 53							
35 AS	No. 0 1-way Vertical Wheel Stand.....	45							
35 AT	No. 1 1-way Vertical Wheel Stand.....	72							
35 AV	No. 2 1-way Vertical Wheel Stand.....	81							
35 AW	No. 3 1-way Vertical Wheel Stand.....	90							
35 AX	No. 4 1-way Vertical Wheel Stand.....	1 00							
35 AY	½" x 4" Pin.....	04							
35 AZ	4" Wheel.....	09							
35 BA	6" Wheel.....	14							
35 BB	8" Wheel.....	21							
35 BD	10" Wheel.....	36							

## ANTI-FRICTION VERTICAL WHEELS.

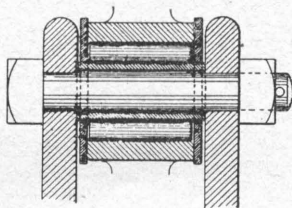
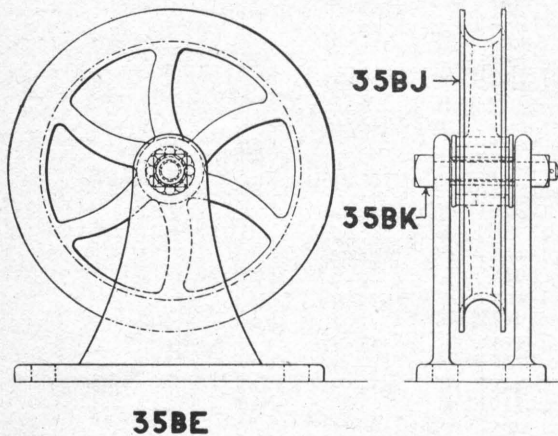

## DETAIL OF ROLLER BEARING

ORDER NO.	35. VERTICAL WHEELS. Anti-Friction Vertical Wheels.	LIST PRICE		WEIGHT	
				LBS	OZS
35 BE	No. 1 1-way 10" Vertical Wheel 6½" high.....	3	38		
35 BF	No. 2 1-way 10" Vertical Wheel 8" high.....	3	49		
35 BG	No. 3 1-way 10" Vertical Wheel 9½" high.....	3	60		
35 BH	No. 4 1-way 10" Vertical Wheel 11" high.....	3	71		
35 BJ	10" Anti-friction Wheel with Ferrule, Rollers and Washers.....	2	60		
35 BK	⅝" x 3¼" Bolt.....		04		

## VERTICAL WHEELS.

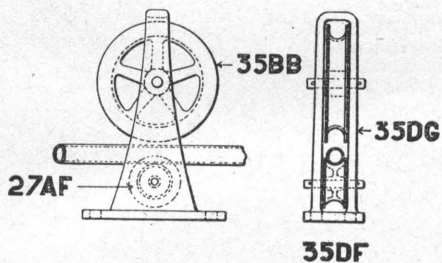
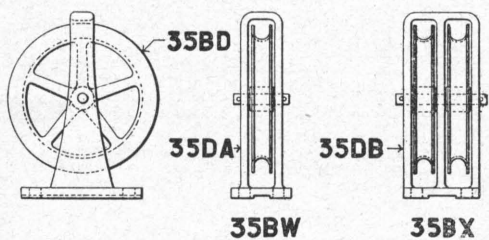
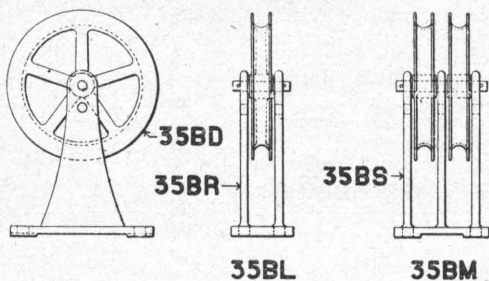

ORDER No.	35. VERTICAL WHEELS.	LIST PRICE		WEIGHT	
				LBS	OZS
35 BL	1-way 10" Vertical Wheel 8½" or 10" high.....	1	20		
35 BM	2-way 10" Vertical Wheel 8½" or 10" high.....	1	78		
35 BN	3-way 10" Vertical Wheel 8½" or 10" high.....	2	36		
35 BP	4-way 10" Vertical Wheel 8½" or 10" high.....	2	94		
35 BR	1-way Vertical Wheel Stand		72		
35 BS	2-way Vertical Wheel Stand		90		
35 BT	3-way Vertical Wheel Stand	1	08		
35 BV	4-way Vertical Wheel Stand	1	26		
<b>Vertical Wheels for Leading Over Top of Wheels.</b>					
35 BW	1-way 10" Vertical Wheel...	1	40		
35 BX	2-way 10" Vertical Wheel	2	08		
35 BY	3-way 10" Vertical Wheel	2	76		
35 BZ	4-way 10" Vertical Wheel	3	44		
35 DA	1-way Vertical Wheel Stand		92		
35 DB	2-way Vertical Wheel Stand	1	20		
35 DD	3-way Vertical Wheel Stand	1	48		
35 DE	4-way Vertical Wheel Stand	1	76		
NOTE.—The above can be fitted with Anti-Friction Wheels if desired					
35 DF	Vertical Wheel for Pipe and Wire.....	1	72		
35 DG	Vertical Wheel Stand only..	1	30		
35 BB	8" Wheel.....		21		
27 AF	Roller.....		07		
35 AY	5" x 4" Pin.....		04		
35 DH	½" x 4" Pin.....		03		



Horizontal Wheels.

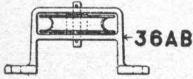
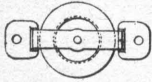

36AA

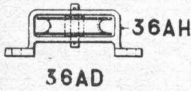
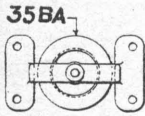

36AD

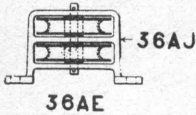

36AE

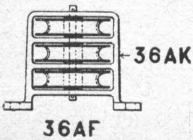

36AF

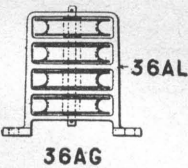

36AG

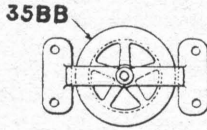

35BB

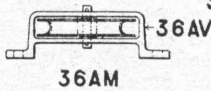

36AM

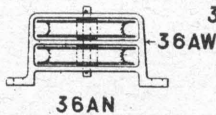

36AN

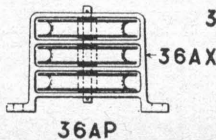

36AP

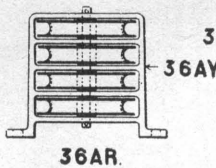

36AR

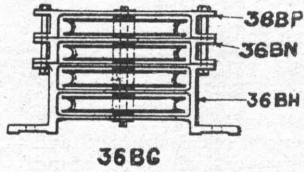

36BG

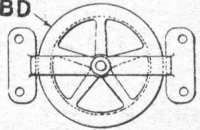

35BD

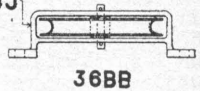

36BB

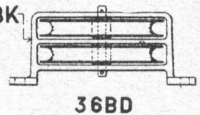

36BD

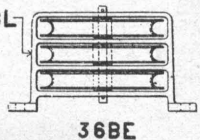

36BE

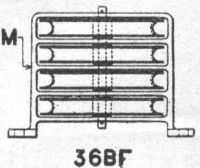

36BF

36BJ

36BK

36BL

36BM

36BP

36BN

36BH

36AB

36AH

36AJ

36AK

36AL

36AV

36AW

36AX

36AY

ORDER NO.	36. HORIZONTAL WHEELS.	LIST PRICE	WEIGHT	
			LBS.	OZS
36 AA	1-way Hor. Wheel complete for Dwarf Signal .....	65		
36 AB	Hor. Stand only including Pin.....	48		
36 AD	1-way 6" Hor. Wheel complete.....	70		
36 AE	2-way 6" Hor. Wheel complete.....	1 00		
36 AF	3-way 6" Hor. Wheel complete.....	1 30		
36 AG	4-way 6" Hor. Wheel complete.....	1 60		
36 AH	1-way Hor. Stand only including Pin for 6" Wheel..	50		
36 AJ	2-way Hor. Stand only including Pin for 6" Wheel..	64		
36 AK	3-way Hor. Stand only including Pin for 6" Wheel..	77		
36 AL	4-way Hor. Stand only including Pin for 6" Wheel	90		
35 BA	6" Wheel.....	14		
36 AM	1-way 8" Hor. Wheel complete.....	80		
36 AN	2-way 8" Hor. Wheel complete.....	1 23		
36 AP	3-way 8" Hor. Wheel complete.....	1 66		
36 AR	4-way 8" Hor. Wheel complete.....	2 09		
36 AS	5-way 8" Hor. Wheel complete.....	2 52		
36 AT	6-way 8" Hor. Wheel complete.....	2 95		
36 AV	1-way Hor. Stand only including Pin for 8" Wheel..	50		
36 AW	2-way Hor. Stand only including Pin for 8" Wheel..	69		
36 AX	3-way Hor. Stand only including Pin for 8" Wheel..	88		
36 AY	4-way Hor. Stand only including Pin for 8" Wheel..	1 07		
36 AZ	5-way Hor. Stand only including Pin for 8" Wheel..	1 26		
36 BA	6-way Hor. Stand only including Pin for 8" Wheel..	1 45		
35 BB	8" Wheel.....	21		
36 BB	1-way 10" Hor. Wheel complete.....	1 00		

ORDER No.	37. HORIZONTAL WHEELS—Cont.	LIST PRICE		WEIGHT	
				LBS.	OZS.
36 BD	2-way 10" Hor. Wheel complete.....	1	65		
36 BE	3-way 10" Hor. Wheel complete.....	2	30		
36 BF	4-way 10" Hor. Wheel complete.....	2	95		
36 BG	4-way Multiple 8" Hor. Wheel complete.....	4	50		
36 BH	2-way Multiple 8" Hor. Wheel Stand, Mall.....		90		
36 BJ	1-way Hor. Stand only including Pin for 10" Wheel.....		55		
36 BK	2-way Hor. Stand only including Pin for 10" Wheel.....		75		
36 BL	3-way Hor. Stand only including Pin for 10" Wheel.....	1	00		
36 BM	4 way Hor Stand only including Pin for 10" Wheel.....	1	25		
36 BN	Extension Sec. for Multiple Wheel.....		50		
36 BP	½" Bolt and Nut for Multiple Wheel.....		06		
35 BD	10" Wheel.....		36		

OFFICE OF THE FEDERAL RAILWAY SIGNAL COMPANY

HORIZONTAL ANTI-FRICTION WHEELS.

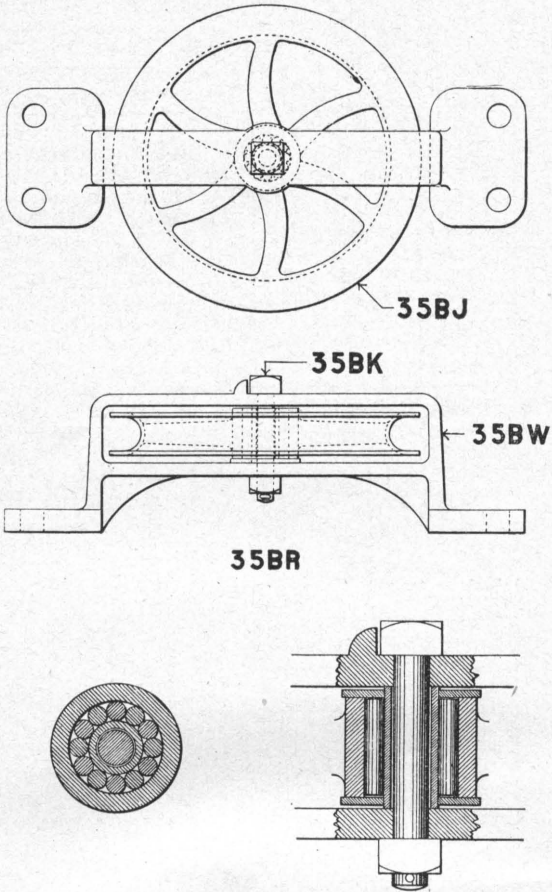

DETAIL OF ROLLER BEARING

ORDER No.	36. HORIZONTAL WHEELS.—Cont.	LIST PRICE	WEIGHT	
			LBS	OZS
36 BR	1-way 10" Hor. Anti-Friction Wheel complete.....	1 75		
36 BS	2-way 10" Hor. Anti-Friction Wheel complete.....	2 30		
36 BT	3-way 10" Hor. Anti-Friction Wheel complete.....	2 85		
36 BV	4-way 10" Hor. Anti-Friction Wheel complete.....	3 40		
36 BW	1-way Hor. Stand only including Bolt for 10" Anti-Friction Wheel.....	55		
36 BX	2-way Hor. Stand only including Bolt for 10" Anti-Friction Wheel.....	68		
36 BY	3-way Hor. Stand only including Bolt for 10" Anti-Friction Wheel.....	81		
36 BZ	4-way Hor. Stand only including Bolt for 10" Anti-Friction Wheel.....	94		
35 BJ	10" Anti-Friction Wheel with Ferrule, Rollers and Washer.....	2 60		



Horizontal Box Wheels:

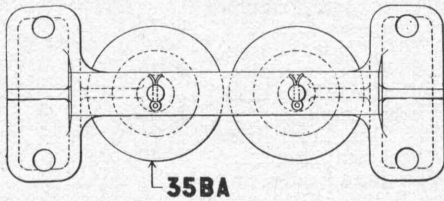

35BA

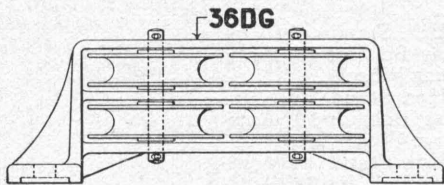

36DB

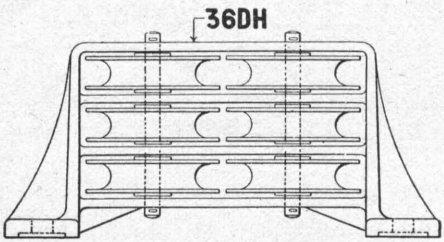

36DD

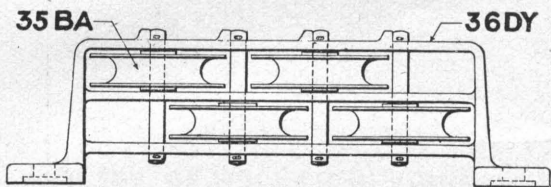

36DV

ORDER NO	36. HORIZONTAL WHEELS—Cont.	LIST PRICE	WEIGHT	
			LBS	OZS
36 DA	2-way 6" Hor. Tandem Wheel complete.....	1 65		
36 DB	4-way 6" Hor. Tandem Wheel complete.....	2 40		
36 DD	6-way 6" Hor. Tandem Wheel complete.....	3 15		
36 DE	8-way 6" Hor. Tandem Wheel complete.....	3 90		
36 DF	2-way 6" Hor. Tandem WheelStand only incl. Pins	1 15		
36 DG	4-way 6" Hor. Tandem WheelStand only incl. Pins	1 65		
36 DH	6-way 6" Hor. Tandem WheelStand only incl. Pins	2 15		
36 DJ	8-way 6" Hor. Tandem Wheel Stand only incl. Pins	2 65		
35 BA	6" Wheel.....	14		
36 DK	2-way 8" Hor. Tandem Wheel complete.....	1 80		
36 DL	4-way 8" Hor. Tandem Wheel complete.....	2 80		
36 DM	6-way 8" Hor. Tandem Wheel complete.....	3 80		
36 DN	8-way 8" Hor. Tandem Wheel complete.....	4 80		
36 DP	2-way 8" Hor. Tandem Wheel Stand including Pins.....	1 40		
36 DR	4-way 8" Hor. Tandem Wheel Stand including Pins.....	1 90		
36 DS	6-way 8" Hor. Tandem Wheel Stand including Pins.....	2 40		
36 DT	8-way 8" Hor. Tandem Wheel Stand including Pins.....	2 90		
35 BB	8" Wheel.....	21		
36 DV	4-way, 2 high, 6" Hor. Staggered Wheel complete....	2 20		
36 DW	6-way, 3 high, Hor. Staggered Wheel complete 6"	2 90		
36 DX	8-way, 4 high, 6" Hor. Staggered Wheel complete....	3 60		
36 DY	4-way, 2 high, Hor. Staggered Wheel Stand including Pins.....	1 75		

ORDER NO	36. HORIZONTAL WHEELS—Cont.	LIST PRICE	WEIGHT	
			LBS	OZS
36 DZ	6-way, 3 high, Hor. Staggered Wheel Stand including Pins.....	2 30		
36 EA	8-way, 4 high, Hor. Staggered Wheel Stand including Pins.....	2 85		

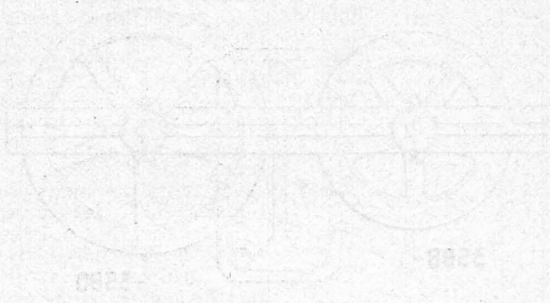

SIGNAL WHEELS.

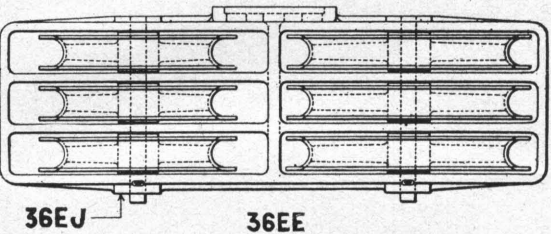
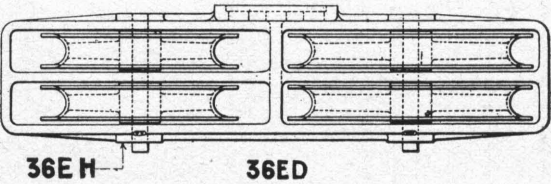
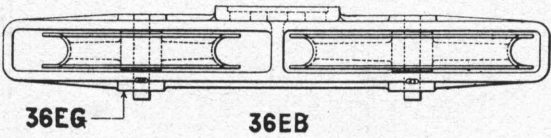
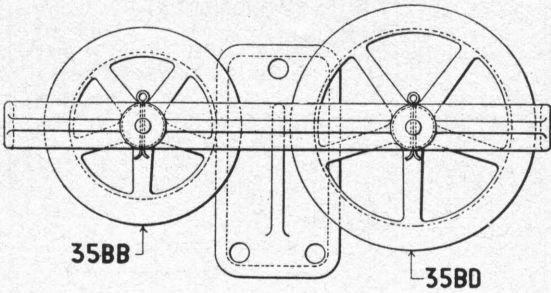

ORDER NO.	36. SIGNAL WHEELS.	LIST PRICE	WEIGHT	
			LBS	OZS
36 EB	2-way 8" and 10" Signal Wheel, complete.....	1 90		
36 ED	4-way 8" and 10" Signal Wheel, complete.....	2 60		
36 EE	6-way 8" and 10" Signal Wheel complete.....	3 30		
36 EF	8-way 8" and 10" Signal Wheel, complete.....	4 00		
36 EG	2-way Signal Wheel Stand only including Pins.....	1 40		
36 EH	4-way Signal Wheel Stand only including Pins.....	1 55		
36 EJ	6-way Signal Wheel Stand only including Pins.....	1 70		
36 EK	8-way Signal Wheel Stand only including Pins.....	1 85		
35 BB	8" Wheel.....	21		
35 BD	10" Wheel.....	36		



Train Order and Block Signals

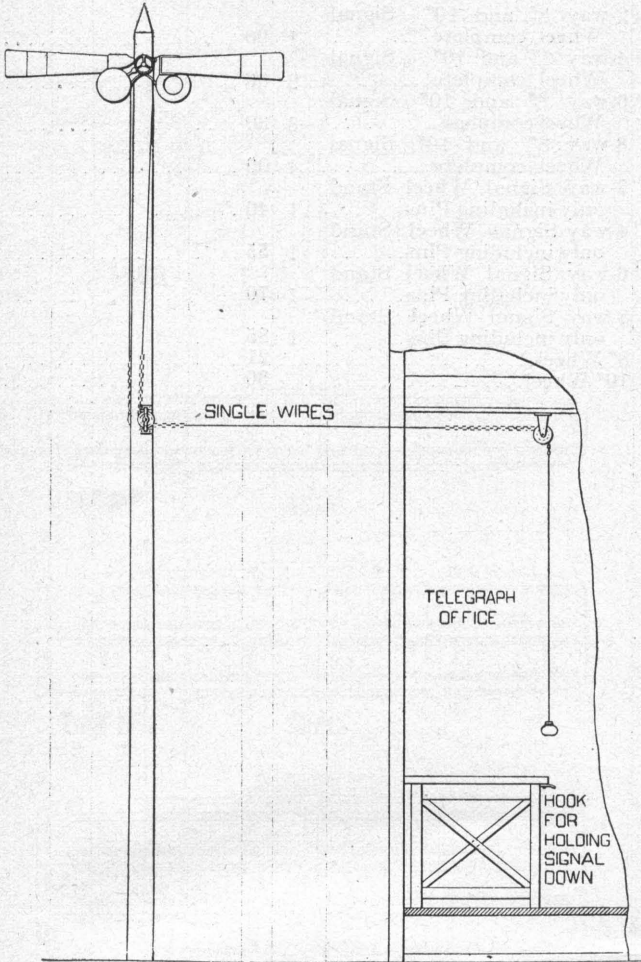

37AA

ORDER No.	37. TRAIN ORDER AND BLOCK SIGNALS.	LIST PRICE		WEIGHT	
				LBS	OZS
37 AA	Two-arm Signal with 27 ft. Wood pole, ladder, lamp and Wire connections complete for signal op- posite office.....	44	00	.....	.....
37 AB	Fittings only, no pole.....	32	00	.....	.....

Train Order and Block Signals.

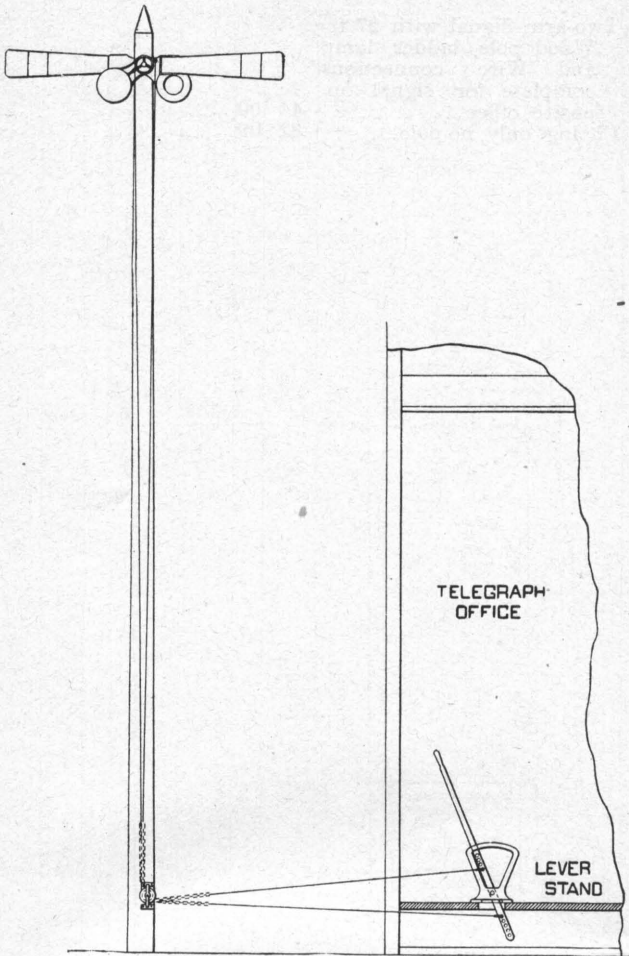

37AD

ORDER NO.	37. TRAIN ORDER AND BLOCK SIGNALS.	LIST PRICE	WEIGHT	
			LBS	OZS
37 AD	Two-arm Signal with 27 ft. Wood pole, ladder, lamp, levers and wire connections complete for Signal opposite office.....	54 00		
37 AE	Two-arm Signal with 27 ft. Iron Pole, ladder, lamp, levers and wire connections complete for Signal opposite office.....	90 00		
37 AF	Fittings only, no pole.....	42 50		

Train Order and Block Signals.

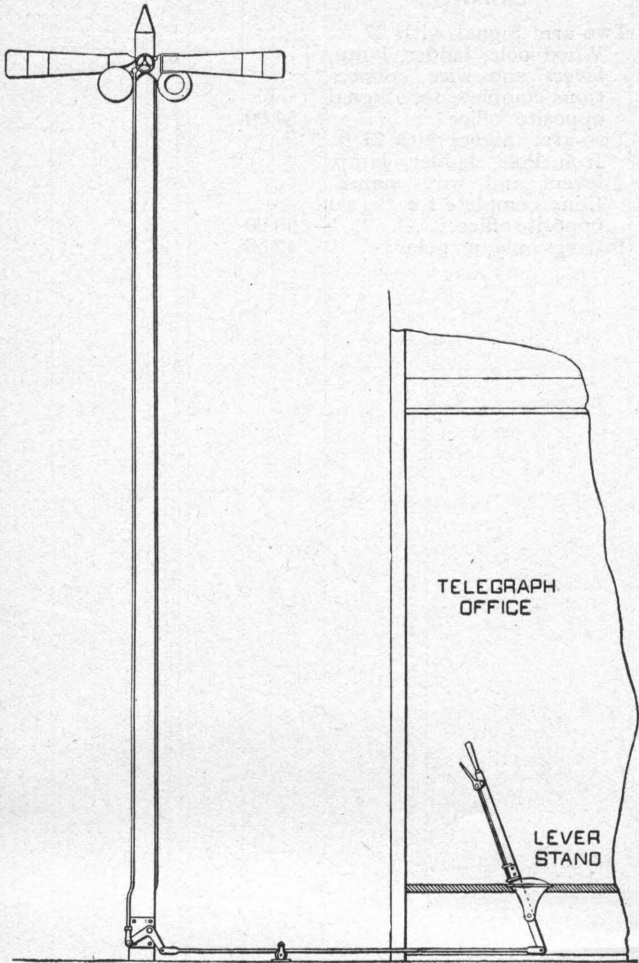

37AG

ORDER No.	37. TRAIN ORDER AND BLOCK SIGNALS.	LIST PRICE	WEIGHT	
			LBS	OZS
37 AG	Two-arm Signal with 27 ft. Wood pole, ladder, lamp, levers and pipe connections complete for Signal not more than 12 ft. from office.....	68 00		
37 AH	Two-arm Signal with 27 ft. Iron pole, ladder, lamp, levers and pipe connections complete for Signal not more than 12 ft. from office.....	105 50		
37 AJ	Fittings only, no pole.....	56 00		



Train Order and Block Signals.

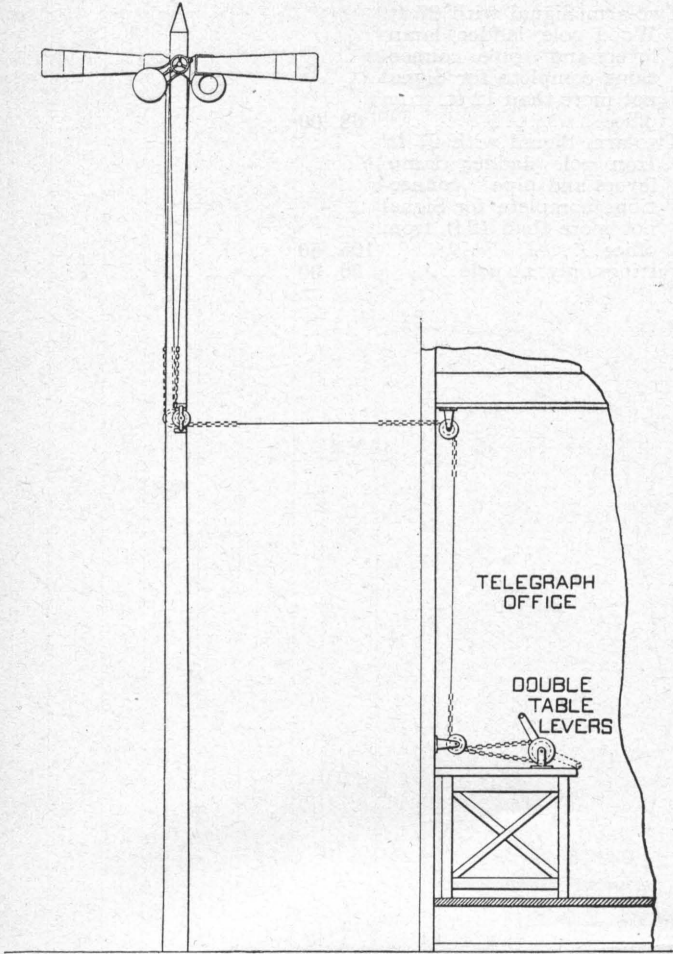

37AK

ORDER NO.	37. TRAIN ORDER AND BLOCK SIGNALS	LIST PRICE		WEIGHT	
				LBS	OZS
37 AK	Two-arm Signal with 27 ft. Wood pole, ladder, lamp, levers and wire connections complete for Signal opposite office.....	65	00		
37 AL	Two-arm Signal with 27 ft. Iron pole, ladder, lamp, levers and wire connections complete for Signal opposite office.....	101	00		
37 AM	Fittings only, no pole.....	51	50		

### Train Order and Block Signals

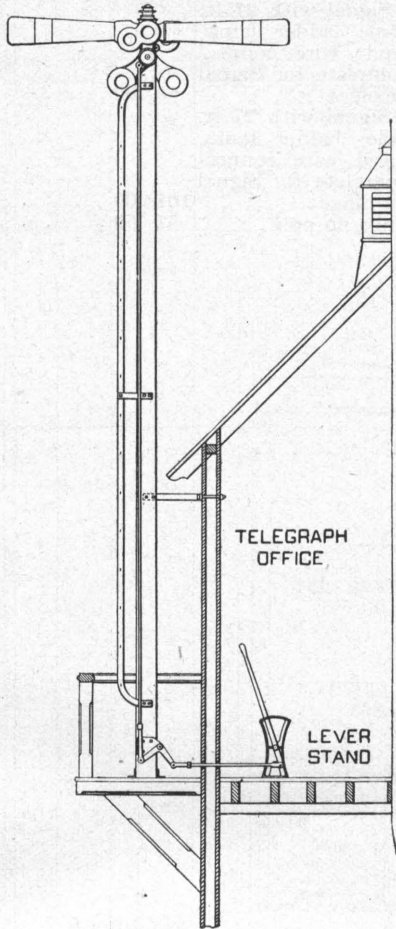

37AN

ORDER NO.	37. TRAIN ORDER AND BLOCK SIGNALS.	LIST PRICE		WEIGHT	
				LBS	OZS
37 AN	Two-arm Signal with 25 ft. Wood pole, ladder, lamp, levers and pipe connections complete.....	61	50	.....	.....
37 AP	Two-arm Signal with 25 ft. Iron pole, ladder, lamp, levers and pipe connections complete.....	95	00	.....	.....
37 AR	Fittings only, no pole.....	54	00	.....	.....

Train Order and Block Signals.

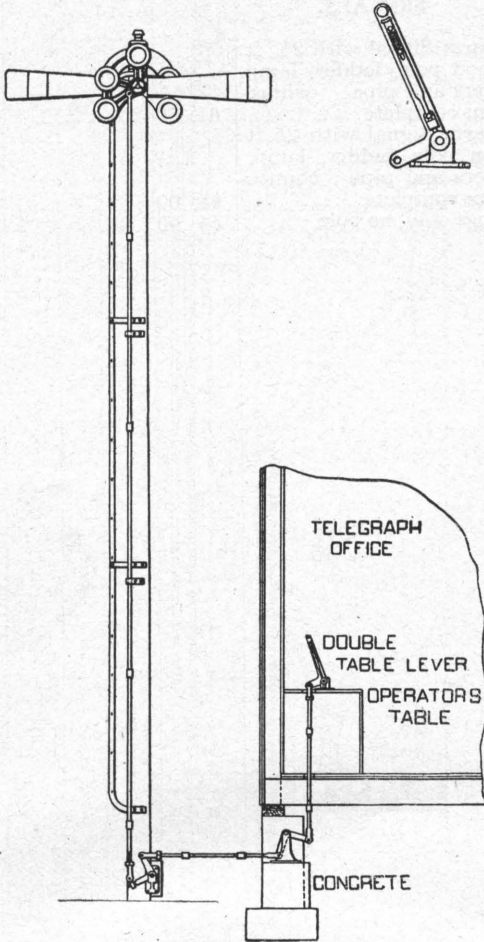

37AS

ORDER No.	37. TRAIN ORDER AND BLOCK SIGNALS.	LIST PRICE	WEIGHT	
			LBS	OZS
37 AS	Two-arm Signal with 32 ft. Wood pole, ladder, lamp, levers and pipe connections complete for Signal not more than 12 ft from office.....	76 00		
37 AT	Two-arm Signal with 32 ft. Iron pole, ladder, lamp, lever and pipe connections complete for Signal not more than 12 ft. from office.....	112 50		
37 AV	Fittings only, no pole.....	62 00		



### Train Order and Block Signal Fittings

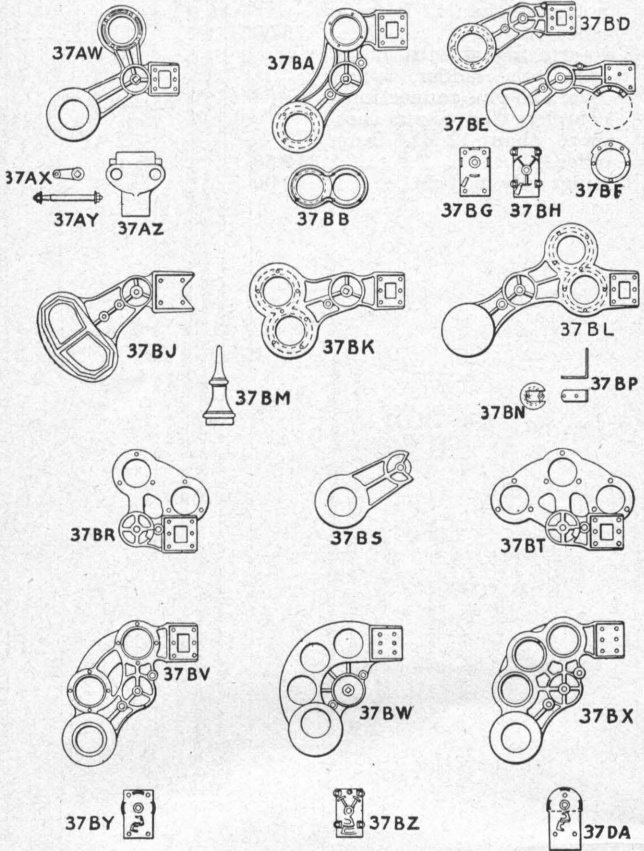

ORDER NO.	37. TRAIN ORDER AND BLOCK SIGNAL FITTINGS.	LIST PRICE	WEIGHT	
			LBS	OZS
37 AW	Two-position 60° Blade grip takes 6½" glass, complete excepting glass.....	3 00		
37 AX	Crank arm for 37-AY.....	25		
37 AY	Spindle complete with Nuts and Washers.....	85		
37 AZ	Semaphore Bearing for Iron pole complete with tap Bolts for 37-AW.....	5 00		
37 BA	Two-position 90° blade grip, takes 6½" glass, complete excepting glass.....	4 60		
37 BB	Double ring for 6½" glass to convert 37-BA into three-position Blade-grip for 60° or 90° signal.....	80		
37 BD	Two-position 60° Blade-grip, takes 6½" glass, complete excepting glass.....	2 15		
37 BE	Two-position 60° Blade grip, takes 6½" glass, complete excepting glass.....	3 45		
37 BF	Lower Rings for 37-BE complete.....	30		
37 BG	Semaphore Bearing for Wood pole, for 37-BD and BE.....	1 80		
37 BH	Semaphore Bearing for Iron pole for 37-BD and BE....	3 20		
37 BJ	Two-position 75° Blade grip, complete excepting glass..	5 20		
37 BK	Three-position 75° Blade grip, takes 6½" glass, complete excepting glass.....	3 85		
37 BL	Three-position 75° Blade grip, takes 6½" glass, complete excepting glass used with 37-BK.....	6 40		
37 BM	Pinnacle for Iron pole where lamp is on the side.....	65		
37 BN	Cap and lamp bracket holder where lamp is on the top..	25		
37 BP	Lamp bracket with screws complete.....	20		
37 BR	Two-position 60° Blade-grip, takes 6½" glass, complete excepting glass.....	2 80		
37 BS	Blade-grip counterweight...	3 70		

ORDER NO.	37. TRAIN ORDER AND BLOCK SIGNAL FITTINGS—Cont.	LIST PRICE	WEIGHT	
			LBS	OZS
37 BT	Three-position, 120° Blade-grip, takes 6½" glass, complete excepting glass.....	3 15		
37 BV	Two-position, 90° Blade-grip, takes 6½" glass, complete excepting glass.....	5 50		
37 BW	Two or three-position, 90° Universal Blade-grip, takes 6½" glass, complete excepting glass.....	5 15		
37 BX	Three-position 90° Blade-grip, takes 6½" glass complete excepting glass.....	6 50		
37 BY	Semaphore Bearing for Wood pole complete with Bolts and Nuts for 37-BV.	1 80		
37 BZ	Semaphore Bearing for Iron pole complete with Bolts and Nuts for 37-BV.....	3 20		
37 DA	Special Semaphore Bearing for Wood pole for 37-BX	1 75		



DISTANT SWITCH SIGNAL.

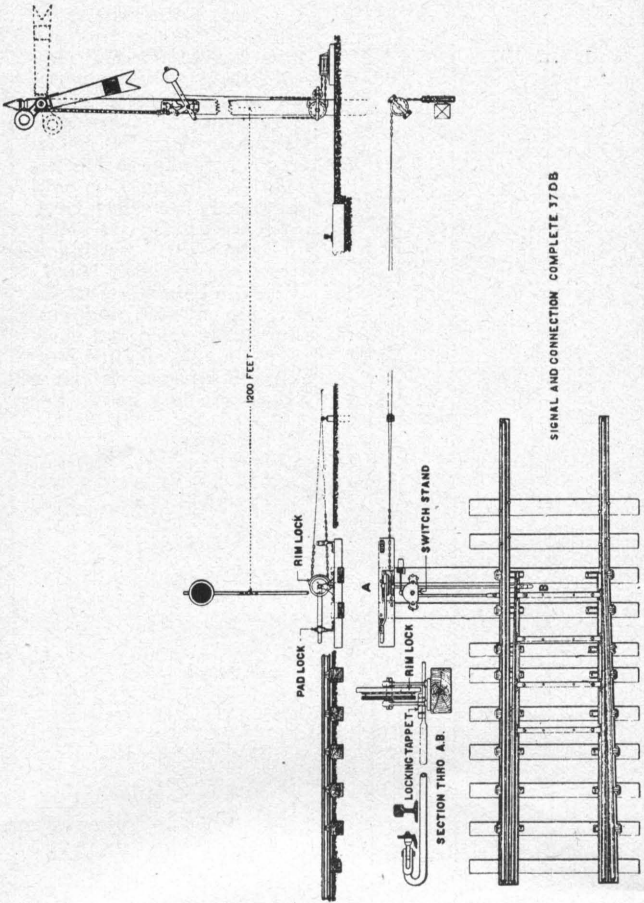

SIGNAL AND CONNECTION COMPLETE 37DB

ORDER NO.	37. DISTANT SWITCH SIGNAL.	LIST PRICE	WEIGHT	
			LBS.	OZS.
37 DB	Distant Switch Signal 37 DB, 2,400 feet of Wire, Stakes, Wire Pulleys and Distant Switch Signal Lever 05 AA., with all Fittings complete except Switch Stand.....	107 00		
37 DD	Distant Switch Signal 37 DD 2,400 feet of Wire, Stakes, Wire Pulleys and Distant Switch Signal Lever 05 AB, with all Fittings complete except Switch Stand.....	108 50		
37 DE	Distant Switch Signal with Signal Movement complete.....	54 00		
37 DF	27 Ft. Post with Cross and Struts.....	30 00		
37 DG	Ladder and Stays.....	9 75		
37 DH	1-way Signal Movement.....	9 75		



ONE ARM SEMAPHORE SIGNAL.

Wire Connected.

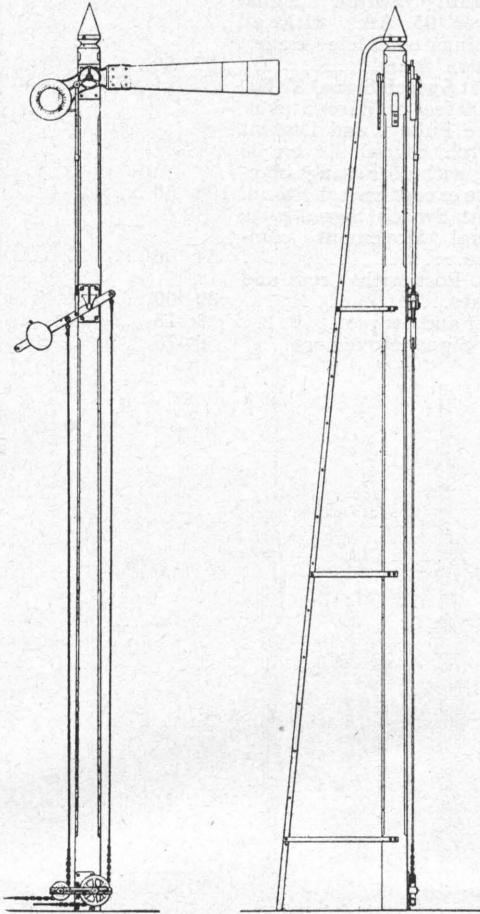

38AA

THE FEDERAL RAILWAY SIGNAL COMPANY  
NEW YORK, N. Y.

ORDER NO.	38. SEMAPHORE SIGNALS. (Wire Connected.)	LIST PRICE	WEIGHT	
			LBS	OZS
38 AA	1-arm Semaphore "Home" or "Distant" Signal 32' high, with Fittings including lamp complete.....	57 50		
38 AB	32 Ft. Wood pole with Cross and Struts.....	24 75		
38 AD	Ladder and Stays.....	9 75		

ONE ARM SEMAPHORE SIGNAL.

Pipe Connected.

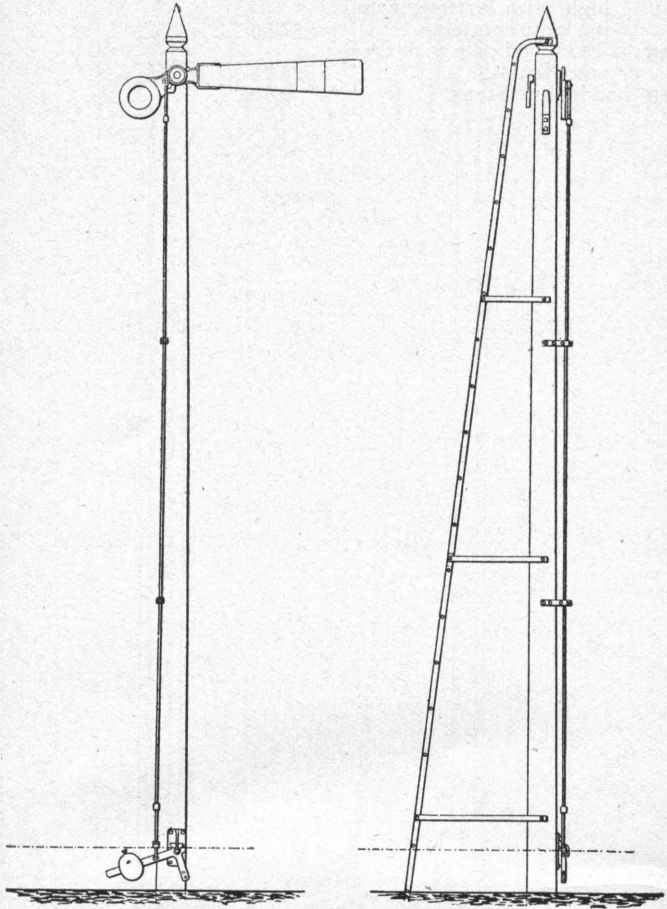

38AE

THE LIBRARY OF  
HENRY J. GRUND

ORDER NO.	38. SEMAPHORE SIGNALS. Pipe Connected.	LIST PRICE	WEIGHT	
			LBS	OZS
38 AE	1-arm Semaphore "Home" or "Distant" Signal 32' high, with Fittings including lamp complete.....	60 00	.....	.....
38 AB	32 Ft. Wood pole with Cross and Struts.....	24 75	.....	.....
38 AD	Ladder and Stays.....	9 75	.....	.....

One-Arm Iron Pole Signal.

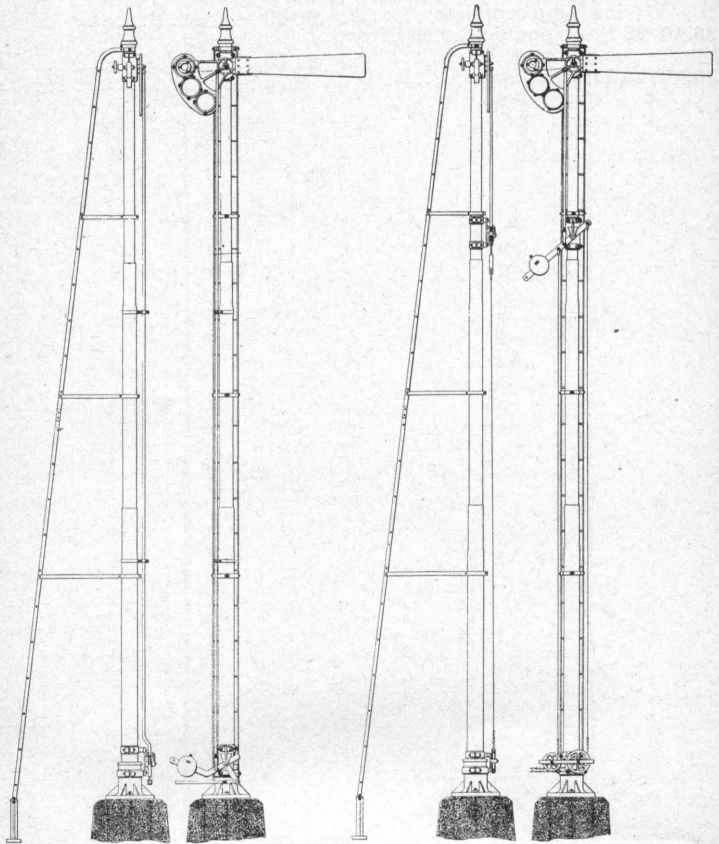

38AG

38AF

ORDER No.	38. SEMAPHORE SIGNALS.	LIST PRICE		WEIGHT	
				LBS	OZS
38 AF	1-arm Wire connected iron Pole Signal, complete.....	90	00		
38 AG	1-arm Pipe connected Iron Pole Signal complete.....	92	00		
38 AH	Iron Pole, Base and Pinnacle for 1-arm Signal.....	48	00		
38 AJ	Ladder and Stays complete for 1-arm Iron Pole Signal.	10	00		



TWO ARM SEMAPHORE SIGNAL.

Wire Connected.

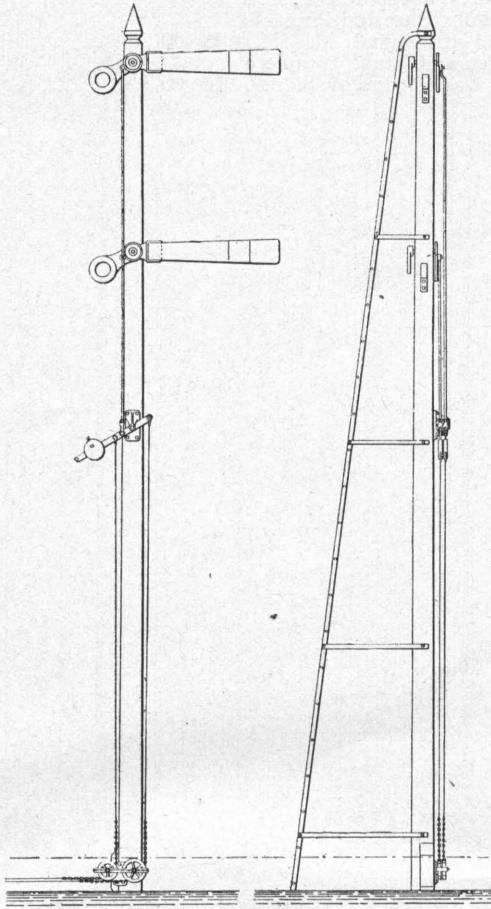

38AK

ORDER NO.	38. SEMAPHORE SIGNALS. Wire Connected.	LIST PRICE		WEIGHT	
				LBS	OZS
38 AK	2-arm Semaphore "Home" or "Home and Distant" Signal 38' 0" high, with Fittings including lamps complete.....	86	00		
38 AL	38 Ft. Wood pole with Cross and Struts.....	29	25		
38 AM	Ladder and Stays.....	12	00		

TWO ARM SEMAPHORE SIGNAL.

Pipe Connected.

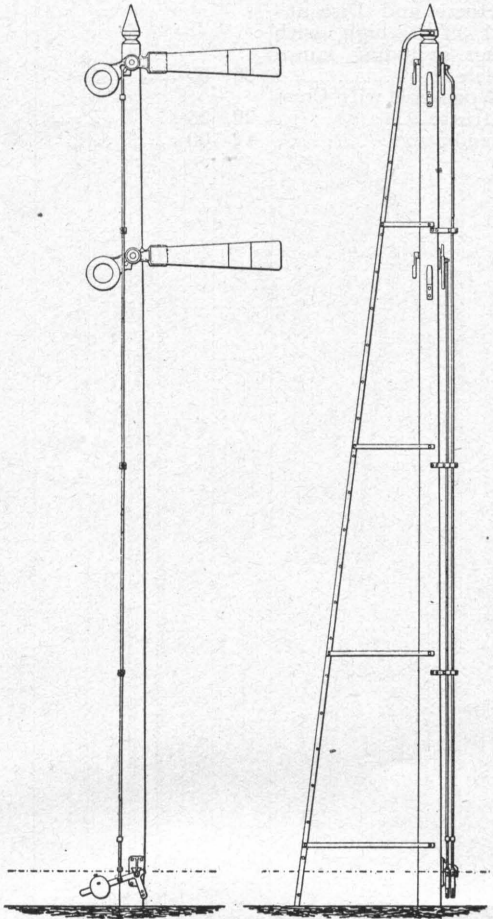

38AN

ORDER NO.	38. SEMAPHORE SIGNALS. Pipe Connected.	LIST PRICE		WEIGHT	
				LBS	OZS
38 AN	2-arm Semaphore "Home" or "Home and Distant" Signal 38'.0" high, with Fittings including lamps complete.....	91	25	.....	.....
38 AL	38 Ft. Wood pole with Cross and Struts.....	29	25	.....	.....
38 AM	Ladder and Stays.....	12	00	.....	.....

### Two-Arm Iron Pole Signal

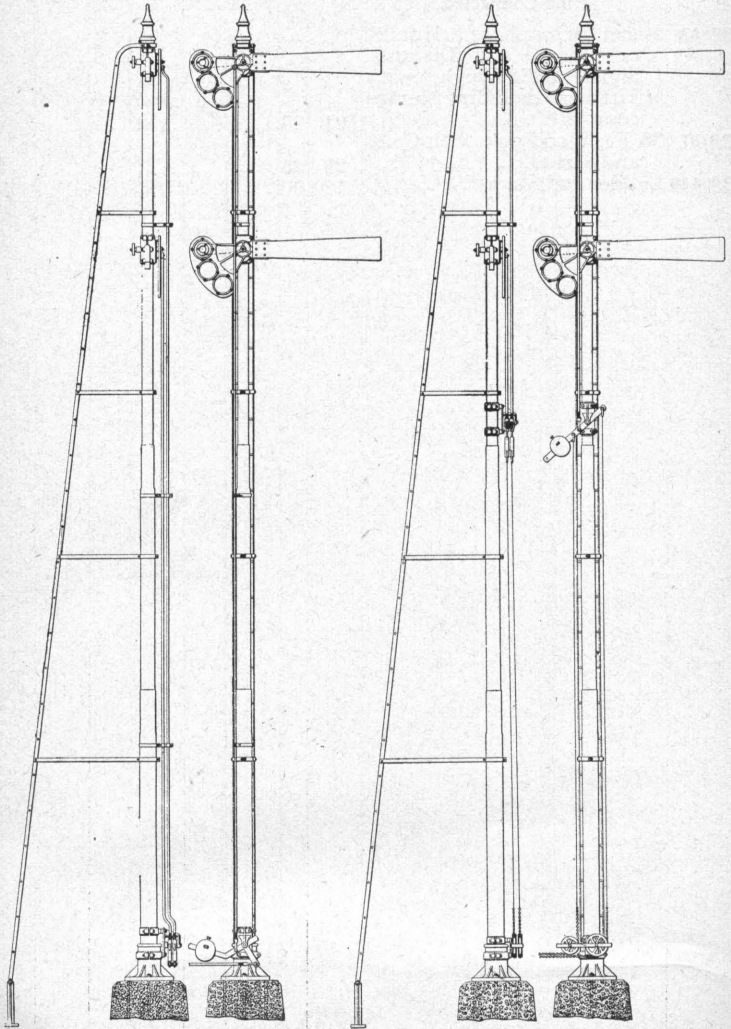

38AR

38AP

ORDER NO.	38. SEMAPHORE SIGNALS.	LIST PRICE		WEIGHT	
				LBS	OZS
38 AP	2-arm Wire connected Iron Pole Signal complete.....	126	50		
38 AR	2-arm Pipe connected Iron Pole Signal complete.....	131	00		
38 AS	Iron Pole, Base and Pinnacle for 2-arm Signal.....	56	00		
38 AT	Ladder and Stays complete for 2-arm Iron Pole Signal.	13	00		



THREE ARM SEMAPHORE SIGNAL.

Wire Connected.

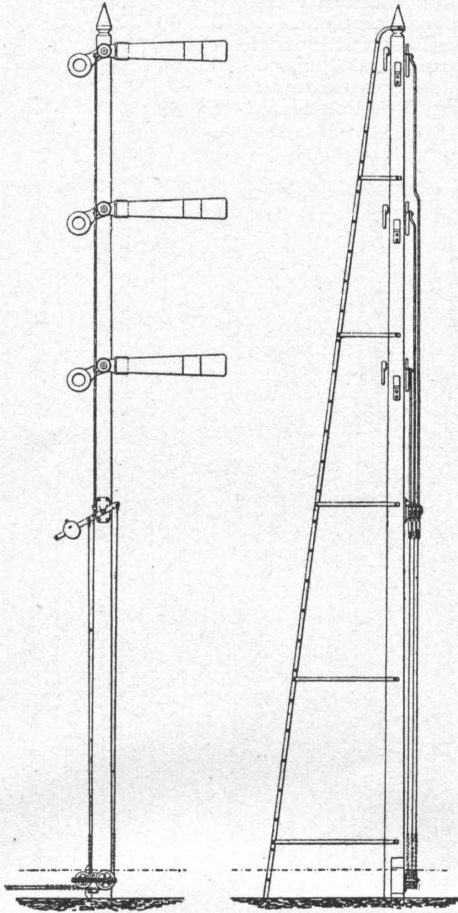

38AV



THREE ARM SEMAPHORE SIGNAL.  
Pipe Connected.

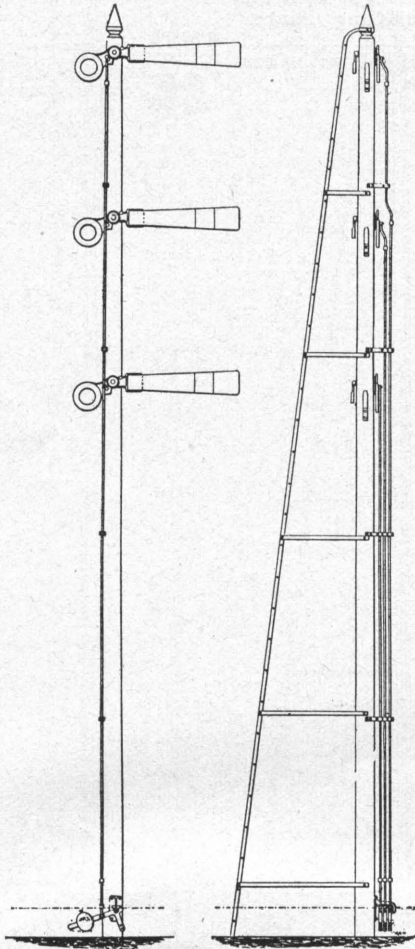

38AY

ORDER No.	38. SEMAPHORE SIGNALS.—Pipe Connected.	LIST PRICE		WEIGHT	
				LBS	OZS
38 AY	3-arm Semaphore "Home" Signal 44' high, with Fittings including lamps complete.....	125	00		
38 AW	44 Ft. Wood pole with Cross and Struts.....	36	00		
38 AX	Ladder and Stays.....	14	00		

Three-Arm Iron Pole Signal.

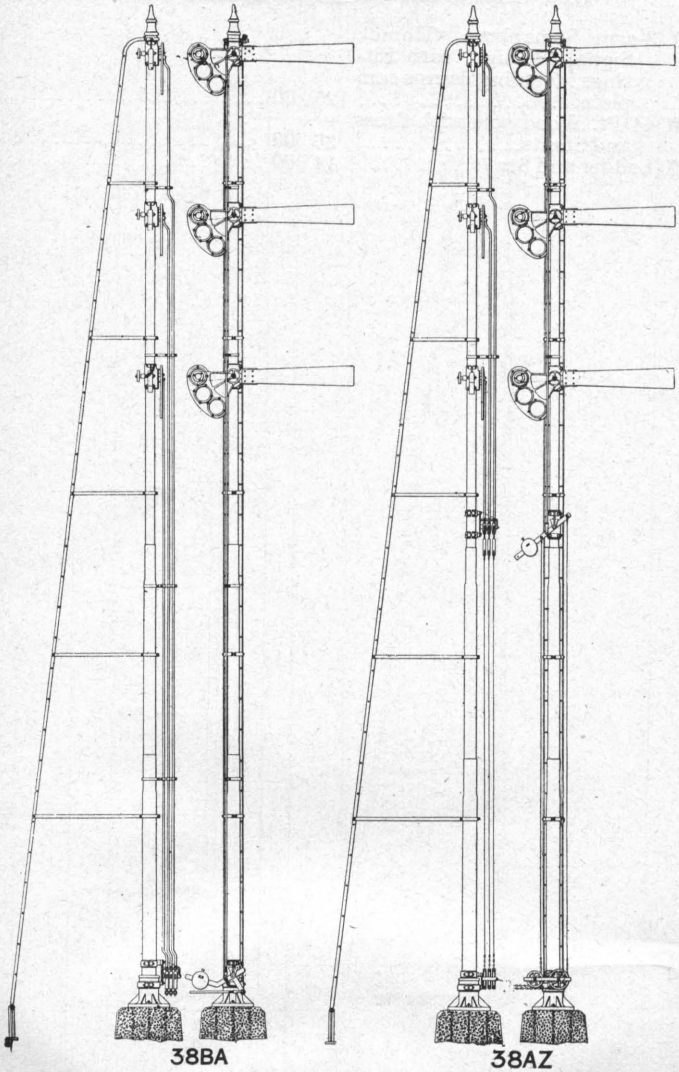

ORDER NO.	38. SEMAPHORE SIGNALS.	LIST PRICE	WEIGHT			
			LBS	OZS		
38 AZ	3-arm Wire connected Iron Pole Signal complete.....	173 00				
38 BA	3-arm Pipe connected Iron Pole Signal complete.....	180 00				
38 BB	Iron pole, base and Pinnacle for 3-arm Signal.....	72 00				
38 BD	Ladder and Stays complete for 3-arm Iron Pole Signal	15 00				



One-Arm Iron Pipe Bridge Signal.

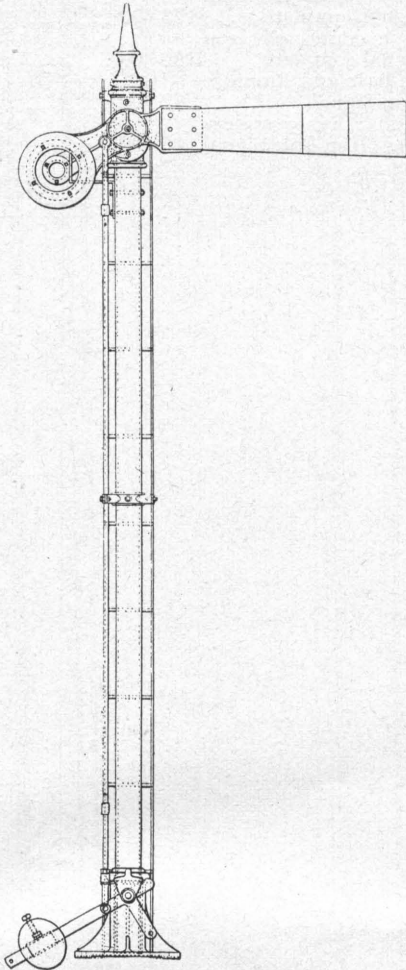

38BE

ORDER NO.	38. IRON PIPE BRIDGE SIGNALS.	LIST PRICE		WEIGHT	
				LBS	OZS
38 BE	4" Pipe Signal, 1-arm with Fittings and lamp complete.....	60	00		
	<b>FITTINGS.</b>				
38 BF	4" Pipe pole with Base for one Balance Lever.....	18	75		
38 BG	Ladder and Stays.....	4	75		

Two-Arm Iron Pipe Bridge Signal.

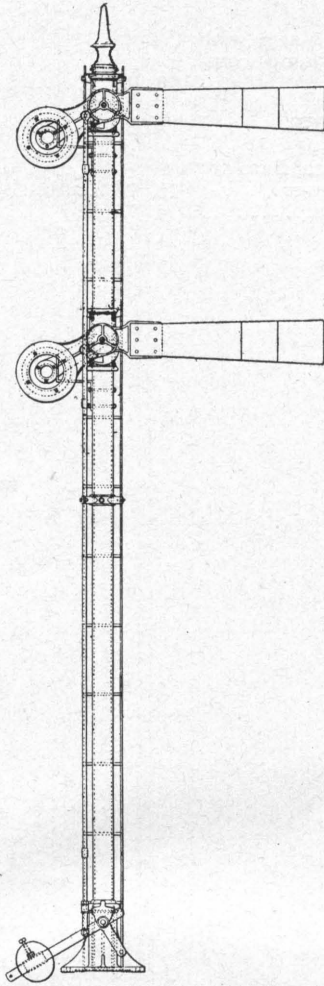

38BH

ORDER NO.	38. IRON PIPE BRIDGE SIGNALS.	LIST PRICE		WEIGHT	
				LBS	OZS
38 BH	4" Pipe, 2-arm Signal, with Fittings and lamp complete.....	95	00		
38 BJ	4" Pipe pole with Base for two Balance Levers.....	22	75		
38 BK	Ladder and Stays.....	7	50		

Iron Pipe Bridge Signals.

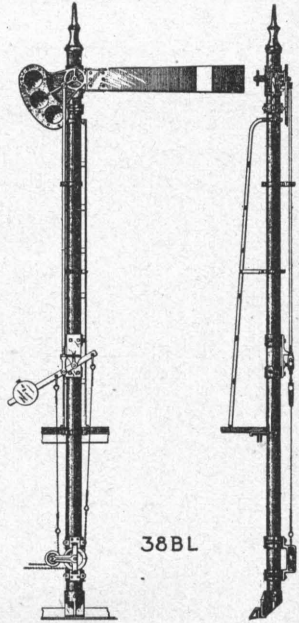
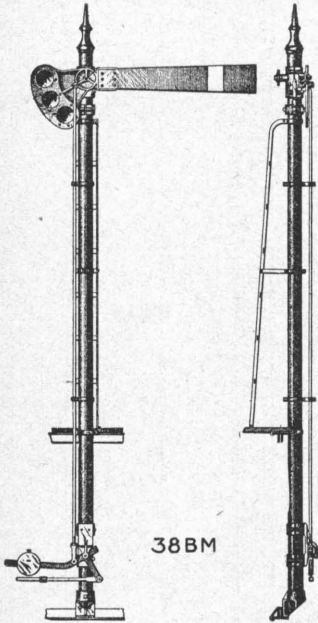

ORDER NO.	38. IRON PIPE BRIDGE SIGNALS.	LIST PRICE		WEIGHT	
				LBS.	OZS.
38 BL	1-arm Iron pole wire connected Bridge Signal.....	47	50	.....	.....
38 BM	1-arm Iron pole pipe connected Bridge Signal.....	48	00	.....	.....
38 BN	Pole with Base, Pinnacle and Clamp.....	12	75	.....	.....
38 BP	Ladder and Stays.....	4	00	.....	.....



## Semaphore Signal Fittings.

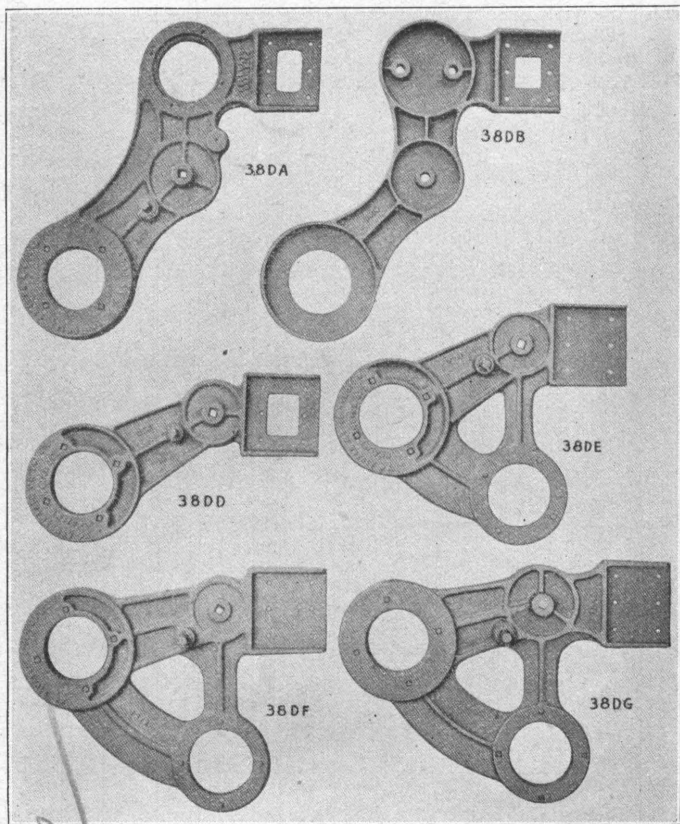

ORDER NO.	38. SEMAPHORE SIGNAL FITTINGS.	LIST PRICE	WEIGHT	
			LBS	OZS
38 DA	One-light, 90° Blade grip takes 6½" glass, complete excepting glass.....	4 60		
38 DB	Blade grip for fixed Blade...	1 90		
38 DD	One-light, 60° Blade grip takes 6½" glass, complete excepting glass.....	3 00		
38 DE	Two-light, 60° Blade grip takes 6½" glass, complete excepting glass.....	4 00		
38 DF	Two-light 75° Blade grip, takes 6½" glass complete excepting glass.....	4 25		
38 DG	Two-light, 75° Blade grip, takes 6¾" glass, complete excepting glass.....	4 25		

### Semaphore Signal Fittings

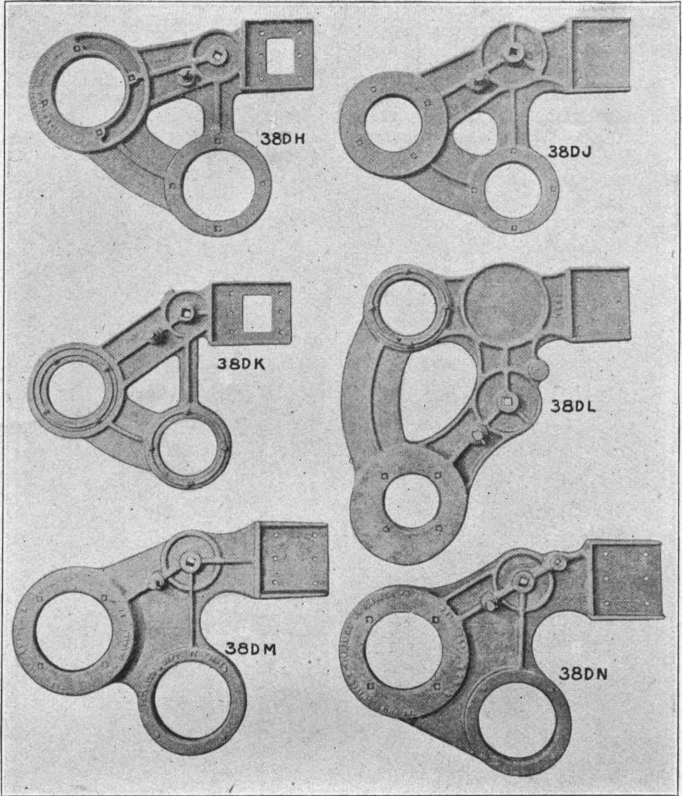

ORDER No.	38. SEMAPHORE SIGNAL FITTINGS —Continued.	LIST PRICE		WEIGHT	
				LBS	OZS
38 DH	Two-light, 75° Blade grip, takes 8 <sup>3</sup> / <sub>8</sub> " glass, complete excepting glass.....	4	50	.....	.....
38 DJ	Two-light, 60° Blade grip, takes 6 <sup>7</sup> / <sub>8</sub> " glass, complete excepting glass.....	4	00	.....	.....
38 DK	Two-light, 45° Blade grip, takes 6 <sup>3</sup> / <sub>4</sub> " glass, complete excepting glass.....	4	00	.....	.....
38 DL	Two-light, 90° Blade grip, takes 6 <sup>1</sup> / <sub>2</sub> " glass, complete excepting glass.....	6	50	.....	.....
38 DM	Two-light, 60° Blade grip, takes 8 <sup>3</sup> / <sub>8</sub> " glass, complete excepting glass.....	4	60	.....	.....
38 DN	Two-light, 60° Blade grip, takes 8 <sup>3</sup> / <sub>8</sub> " glass, complete excepting glass.....	5	00	.....	.....

Semaphore Signal Fittings.

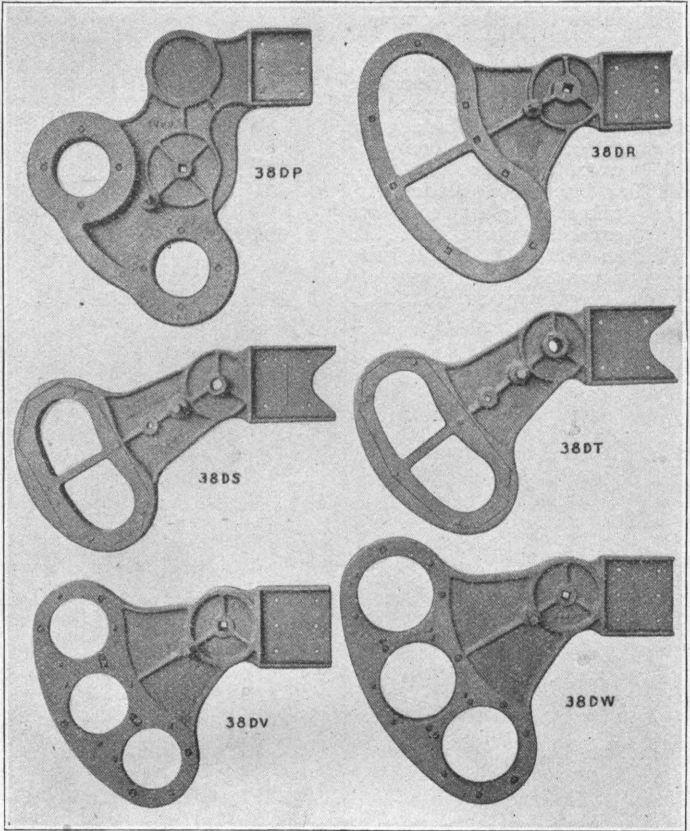

ORDER NO.	38. SEMAPHORE SIGNAL FITTINGS. —Continued.	LIST PRICE		WEIGHT	
				LBS	OZS
38 DP	Two-light, 90° Blade grip, takes 6½" glass, complete excepting glass.....	6	80		
38 DR	Two-light, 60° Blade grip, complete excepting glass..	5	75		
38 DS	Two-light, 60° Blade grip, complete excepting glass	5	10		
38 DT	Two-light, 60° Blade grip, complete excepting glass	5	40		
38 DV	Three-light, 60° Blade grip, takes 6½" glass, complete excepting glass.....	4	80		
38 DW	Three-light, 60° Blade grip, takes 8¾" glass, complete excepting glass.....	4	50		



Semaphore Signal Fittings.

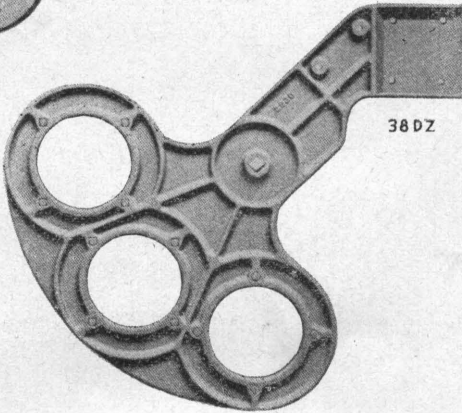
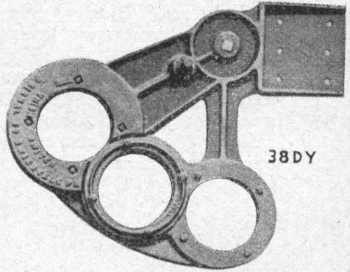
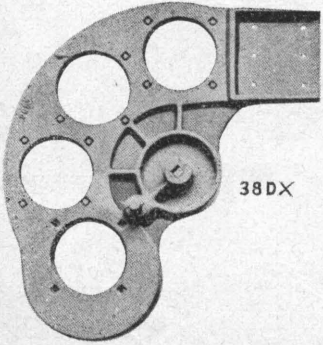

ORDER No.	38. SEMAPHORE SIG- NAL FITTINGS—Cont.	LIST PRICE	WEIGHT	
			LBS	OZS
38 DX	Three-light, 90° Blade grip, takes 6½" glass, complete excepting glass.....	5 70	.....	.....
38 DY	Three-light, 75° Blade grip, takes 6½" glass, complete excepting glass.....	4 00	.....	.....
38 DZ	Three-light, 90° Blade grip, takes 8¾" glass, complete excepting glass.....	6 50	.....	.....

Semaphore Signal Fittings



38EA



38EB

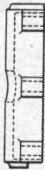
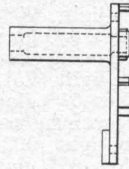

38EF

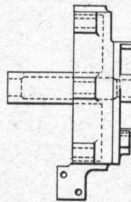

38EE

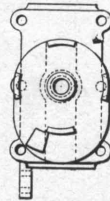

38ED

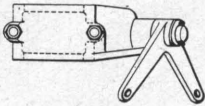

38EG



38EH

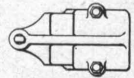

38EM

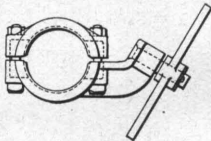

38ET

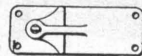
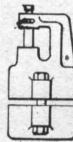

38EX

ORDER No.	38. SEMAPHORE SIGNAL FITTINGS.—Cont.	LIST PRICE	WEIGHT	
			LBS	OZS
38 EA	Semaphore Bearing for Wood pole, centre Stop...	90		
38 EB	Semaphore Bearing for Wood Pole, Side Stop .....	90		
38 ED	Semaphore Bearing for Iron Pole, complete with Bolts	2 70		
38 EE	Front half Sema. Bearing for Iron Pole.....	1 60		
38 EF	Back half Sema. Bearing for Iron Pole.....	78		
38 EG	Clamp Crank Stand and Crank complete.....	2 25		
38 EH	1-way Clamp Bal. Lever Stand for 5" Pipe.....	2 35		
38 EJ	2-way Clamp Bal. Lever Stand for 5" Pipe.....	2 50		
38 EK	1-way Clamp Bal. Lever Stand for 6" Pipe .....	2 50		
38 EL	2-way Clamp Bal. Lever Stand for 6" Pipe.....	2 65		
38 EM	1-way Offset Bal. Lever Stand for 5" Pipe.....	2 50		
38 EN	2-way Offset Bal. Lever Stand for 5" Pipe.....	2 80		
38 EP	3-way Offset Bal. Lever Stand for 5" Pipe.....	3 10		
38 ER	Clamps complete with Bolts for 4" Pipe.....	1 10		
38 ES	Clamps complete with Bolts for 5" Pipe.....	1 15		
38 ET	Clamps complete with Bolts for 6" Pipe.....	1 20		
38 EV	Clamps complete with Bolts for 7" Pipe.....	1 30		
38 EW	Clamps complete with Bolts for 8" Pipe.....	1 40		
38 EX	1-way Balance Lever Stand for Wood Pole, or separate Clamps on Iron Pole.....	1 25		
38 EY	2-way Balance Lever Stand for Wood Pole, or separate Clamps on Iron Pole.....	1 45		
38 E	3-way Balance Lever Stand for Wood pole, or separate Clamps on Iron Pole.....	1 65		
38 FA	4-way Balance Lever Stand for Wood pole, or separate Clamps on Iron Pole.....	1 85		

Semaphore Signal Fittings.

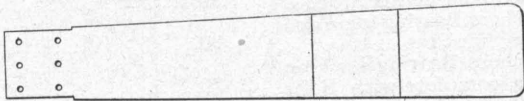

38FT

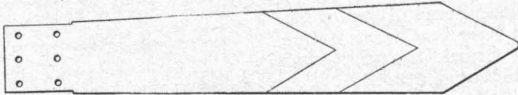

38FV



38FW



38FS

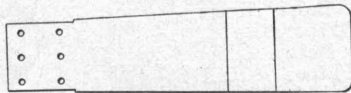

38FX

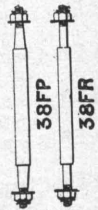

38FP

38FR

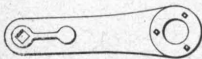

38FB



38FD

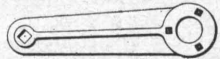

38FE

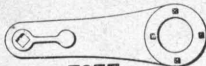

38FF

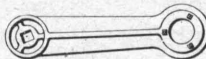

38FG

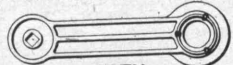

38FH

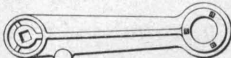

38FJ

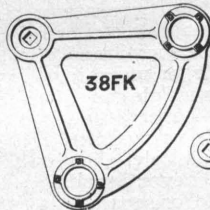

38FK



38FL

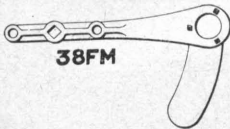

38FM

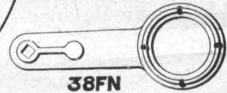

38FN

ORDER NO.	38. SEMAPHORE SIGNAL FITTINGS—Cont.	LIST PRICE	WEIGHT	
			LBS.	OZS
38 FB	Back Spectacle complete excepting glass for 38-DA, 38-DD, 38-DE, 38-DF, 38-DG, 38-DH, 38-DL 38-DM or 38-DY.....	85		
38 FD	Back Spectacle complete excepting glass for 38-DP or 38-DX.....	85		
38 FE	Back Spectacle complete excepting glass for 38-DJ.....	85		
38 FF	Back Spectacle complete excepting glass for 38-DZ..	85		
38 FG	Back Spectacle complete excepting glass for 38-DV...	80		
38 FH	Back Spectacle complete excepting glass for 38-DK...	95		
38 FJ	Back Spectacle complete excepting glass for 38-DW...	1 05		
38 FK	Back Spectacle complete excepting glass for 38-DF...	1 40		
38 FL	Back Spectacle complete excepting glass for 38-DS....	80		
38 FM	Back Spectacle complete excepting glass for 38-DN...	1 00		
38 FN	Back Spectacle complete excepting glass for 38-DA or 38-DD.....	80		
38 FP	Taper Semaphore Spindle complete.....	1 25		
38 FR	Straight Semaphore Spindle complete.....	1 25		
38 FS	Lamp Bracket.....	1 34		
38 FT	Home Signal Blade.....	1 30		
38 FV	Block Signal Blade.....	1 30		
38 FW	Distant Signal Blade.....	1 30		
38 FX	Route Signal Blade.....	1 20		



### Semaphore Signal Fittings.

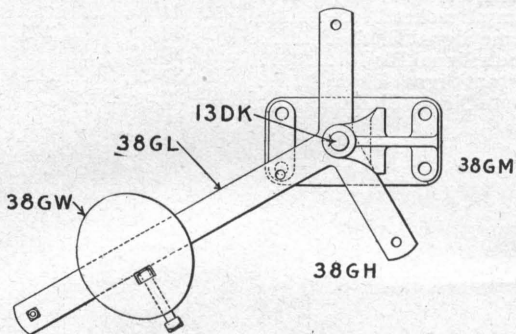
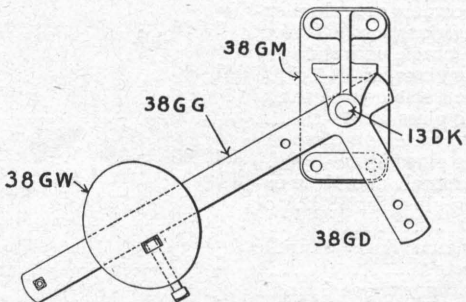
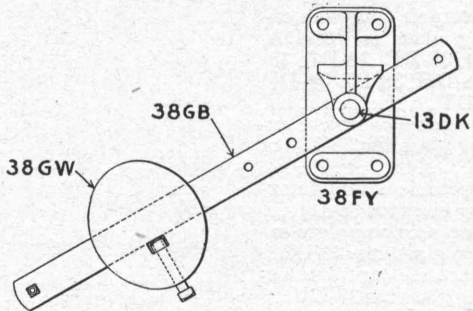

ORDER No.	38. SEMAPHORE SIGNAL FITTINGS. —Continued.	LIST PRICE		WEIGHT	
				LBS	OZS
38 FY	1-way Straight Bal. Lever, 18 lb. Weight, and Stand complete.....	3	35		
38 FZ	2-Way Straight Bal. Lever, 18 lb Weight, and Stand complete.....	5	50		
38 GA	3-way Straight Bal. Lever, 18 lb. Weight, and Stand complete.....	7	80		
38 GB	Straight Balance Lever.....	1	15		
38 GD	1-way "L" Balance Lever, 18 lb. Weight, and Stand complete.....	4	25		
38 GE	2-way "L" Balance Lever, 18 lb. Weight, and Stand complete.....	7	30		
38 GF	3-way "L" Balance Lever, 18 lb.* Weight, and Stand complete.....	10	50		
38 GG	"L" Balance Lever.....	2	05		
38 GH	1-way "T" Balance Lever, 18 lb. Weight, and Stand complete.....	3	95		
38 GJ	2-way "T" Bal. Lever, 18 lb. Weight and Stand complete.....	6	70		
38 GK	3-way "T" Balance Lever, 18 lb. Weight, and Stand complete.....	9	60		
38 GL	"T" Balance Lever.....	1	75		
38 GM	1-way Balance Lever Stand	1	15		
38 GN	2-way Balance Lever Stand	1	25		
38 GP	3-way Balance Lever Stand	1	40		
13 DK	1-way Pin for Balance Lever Stand.....		12		
13 DL	2-way Pin for Balance Lever Stand.....		15		
13 DM	3-way Pin for Balance Lever Stand.....		18		
13 DN	1— $\frac{1}{4}$ " x $3\frac{1}{2}$ " Split Cotter to each Pin.....		01		
38 GW	18 lb. Weight with Bolt complete.....		95		

## Semaphore Signal Fittings.

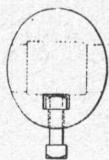

38GR

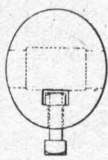

38GS

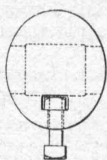

38GT

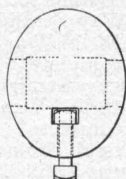

38GV

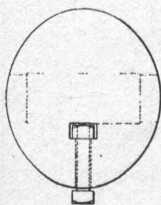

38GW

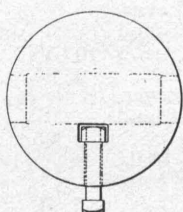

38GX

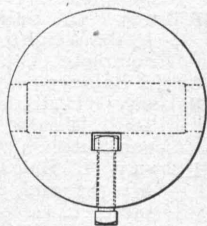

38GY

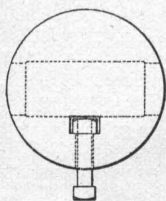

38GZ

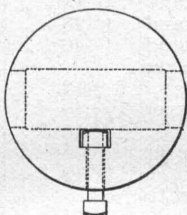

38HA

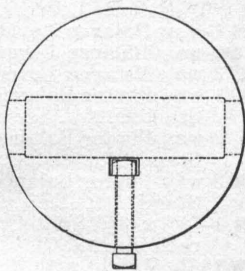

38HB

ORDER NO.	38. SEMAPHORE SIGNAL FITTINGS—Con.	LIST PRICE	WEIGHT	
			LBS.	OZS
38 GR	7 lb. Weight complete with Bolt.....	30		
38 GS	10 lb. Weight complete with Bolt for $\frac{3}{8}$ " x $1\frac{1}{4}$ " Lever....	43		
38 GT	10 lb. Weight complete with Bolt for $\frac{1}{2}$ " x $2\frac{1}{4}$ " Lever....	43		
38 GV	14 lb. Weight complete with Bolt.....	60		
38 GW	18 lb. Weight complete with Bolt.....	95		
38 GX	27 lb. Weight complete with Bolt.....	1 15		
38 GY	40 lb. Weight complete with Bolt 8" dia. x $3\frac{1}{2}$ ".....	2 00		
38 GZ	40 lb. Weight complete with Bolt 10" dia. x 2".....	2 00		
38 HA	56 lb. Weight complete with Bolt.....	2 80		
38 HB	100 lb. Weight complete with Bolt.....	4 85		

Semaphore Signal Fittings.

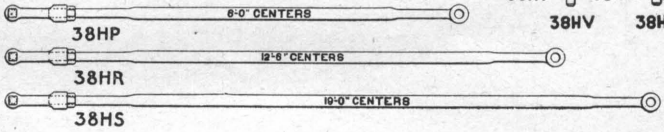
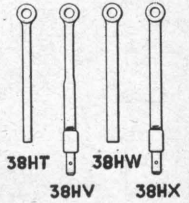
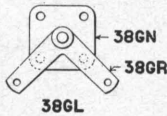
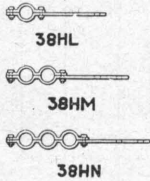
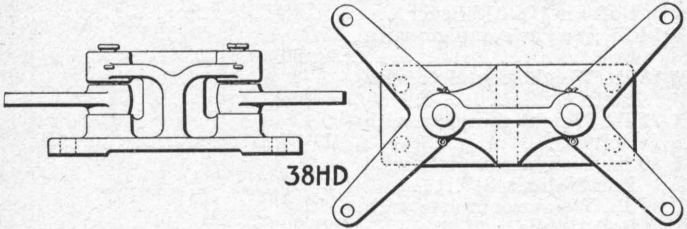

ORDER No.	38. SEMAPHORE SIGNAL FITTINGS.	LIST PRICE	WEIGHT	
			LBS	OZS
38 HD	Double Crank Stand with 7 $\frac{3}{4}$ " x 7 $\frac{3}{4}$ " Cranks complete.	3 40		
38 HE	1-way Special Pin Plate with 7 $\frac{3}{4}$ " x 7 $\frac{3}{4}$ " Crank complete...	1 30		
38 HF	2-way Special Pin Plate with 7 $\frac{3}{4}$ " x 7 $\frac{3}{4}$ " Crank complete.	2 15		
38 HG	1-way Pin Plate with 6" x 6" Crank complete.....	1 10		
38 HH	2-way Pin Plate with 6" x 6" Crank complete.....	2 00		
38 HJ	7 $\frac{3}{4}$ " x 7 $\frac{3}{4}$ " Crank.....	75		
38 HK	6" x 6" Crank.....	50		
38 HL	1-way Rod Guide.....	21		
38 HM	2-way Rod Guide.....	25		
38 HN	3-way Rod Guide.....	30		
38 HP	6' 0" Down Rod with Eye and $\frac{3}{4}$ " Screw Jaw and Pin	1 80		
38 HR	12' 6" Down Rod with Eye and $\frac{3}{4}$ " Screw Jaw and Pin	2 20		
38 HS	19' 0" Down Rod with Eye and $\frac{3}{4}$ " Screw Jaw and Pin	2 60		
38 HT	$\frac{3}{4}$ " Eye, solid end.....	30		
38 HV	$\frac{3}{4}$ " Eye, tang end.....	50		
38 HW	1" Eye, solid end.....	35		
38 HX	1" Eye, tang end.....	55		



Semaphore Signal Fittings.

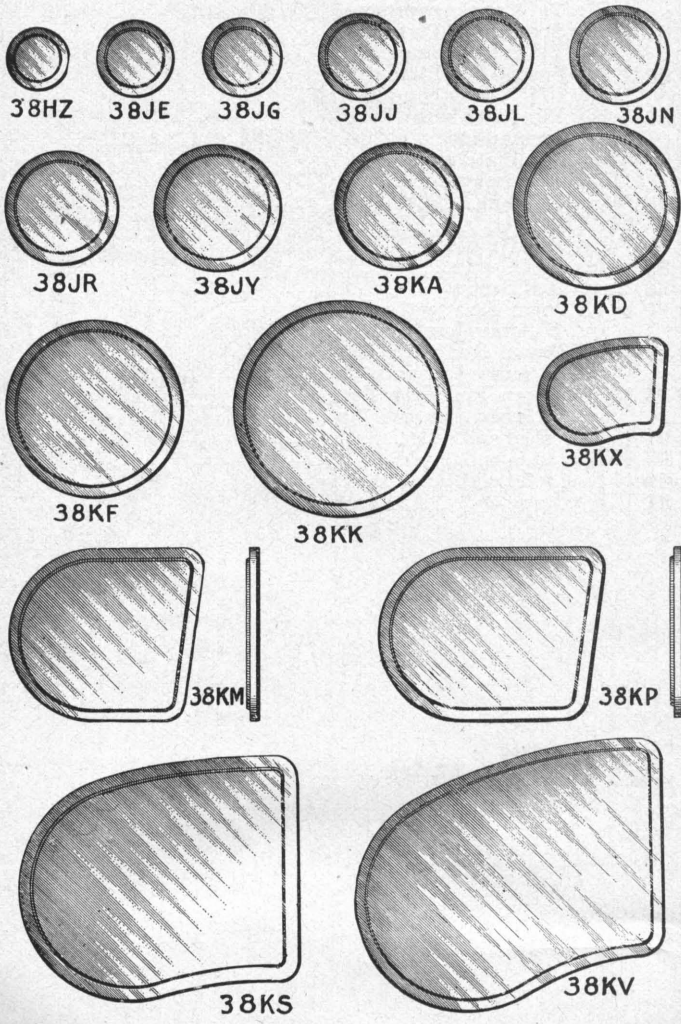

ORDER No.	38. SEMAPHORE SIGNAL FITTINGS —Continued.	LIST PRICE					
		RED	GREEN	YELLOW	BLUE	PURPLE	CLEAR
38 HY	2 <sup>3</sup> / <sub>8</sub> " Plain Glass.....	.07	.07	.07	.07	.07	.03
38 HZ	2 <sup>3</sup> / <sub>8</sub> " Roundell.....	.28	.14	.14	.14	.14	.09
38 JA	2 <sup>1</sup> / <sub>2</sub> " Plain Glass.....	.07	.07	.07	.07	.07	.03
38 JB	2 <sup>1</sup> / <sub>2</sub> " Roundell.....	.29	.14	.14	.14	.14	.09
38 JD	2 <sup>7</sup> / <sub>8</sub> " Plain.....	.09	.09	.09	.09	.09	.04
38 JE	2 <sup>7</sup> / <sub>8</sub> " Roundell.....	.36	.18	.18	.18	.18	.10
38 JF	3" Plain.....	.09	.09	.09	.09	.09	.04
38 JG	3" Roundell.....	.36	.18	.18	.18	.18	.10
38 JH	3 <sup>1</sup> / <sub>2</sub> " Plain.....	.10	.10	.10	.10	.10	.05
38 JJ	3 <sup>1</sup> / <sub>2</sub> " Roundell.....	.43	.21	.21	.21	.21	.14
38 JK	3 <sup>3</sup> / <sub>8</sub> " Plain.....	.10	.10	.10	.10	.10	.05
38 JL	3 <sup>3</sup> / <sub>8</sub> " Roundell.....	.43	.25	.25	.25	.25	.18
38 JM	4" Plain.....	.12	.12	.12	.12	.12	.05
38 JN	4" Roundell.....	.43	.25	.25	.25	.25	.18
38 JP	4 <sup>1</sup> / <sub>2</sub> " Plain.....	.13	.13	.13	.13	.13	.06
38 JR	4 <sup>1</sup> / <sub>2</sub> " Roundell.....	.50	.28	.28	.28	.28	.20
38 JS	4 <sup>3</sup> / <sub>8</sub> " Plain.....	.14	.14	.14	.14	.14	.06
38 JT	4 <sup>3</sup> / <sub>8</sub> " Roundell.....	.50	.29	.29	.29	.29	.20
38 JV	4 <sup>3</sup> / <sub>8</sub> " Plain.....	.15	.15	.15	.15	.15	.07
38 JW	4 <sup>3</sup> / <sub>8</sub> " Roundell.....	.54	.36	.36	.36	.36	.23
38 JX	5" Plain.....	.17	.17	.17	.17	.17	.07
38 JY	5" Roundell.....	.54	.36	.36	.36	.36	.23
38 JZ	5 <sup>3</sup> / <sub>8</sub> " Plain.....	.19	.19	.19	.19	.19	.08
38 KA	5 <sup>3</sup> / <sub>8</sub> " Roundell.....	.54	.36	.36	.36	.36	.25
38 KB	6 <sup>1</sup> / <sub>2</sub> " Plain.....	.24	.24	.24	.24	.24	.09
38 KD	6 <sup>1</sup> / <sub>2</sub> " Roundell.....	.90	.50	.50	.50	.50	.36
38 KE	6 <sup>3</sup> / <sub>8</sub> " Plain.....	.27	.27	.27	.27	.27	.11
38 KF	6 <sup>3</sup> / <sub>8</sub> " Roundell.....	1.00	.54	.54	.54	.54	.40
38 KG	8" Plain.....	.34	.34	.34	.34	.34	.15
38 KH	8" Roundell.....	1.35	.90	.90	.90	.90	.45
38 KJ	8 <sup>3</sup> / <sub>8</sub> " Plain.....	.38	.38	.38	.38	.38	.15
38 KK	8 <sup>3</sup> / <sub>8</sub> " Roundell.....	1.35	.90	.90	.90	.90	.45
38 KL	P. R. R. 3045 Plain.....	.30	.20	.20	.20	.20	.15
38 KM	P. R. R. 3045 Moulded...	1.15	.50	.50	.50	.50	.45
38 KN	P. R. R. 3047 Plain.....	.40	.30	.30	.30	.30	.20
38 KP	P. R. R. 3047 Moulded...	1.45	.72	.72	.72	.72	.50
38 KR	N. Y. C. Upper, Plain....	.80	.50	.50	.50	.50	...
38 KS	N. Y. C. Upper, Moulded.	2.70	1.35	1.35	1.35	1.35	...
38 KT	N. Y. C. Lower, Plain....	.90	.60	.60	.60	.60	...
38 KV	N. Y. C. Lower Moulded	3.15	1.60	1.60	.60	1.60	...
38 KW	N. Y. C. Dwf., Plain.....	.20	.15	.15	.15	.15	.10
38 KX	N. Y. C. Dwf. Moulded ..	.54	.36	.36	.36	.36	.23

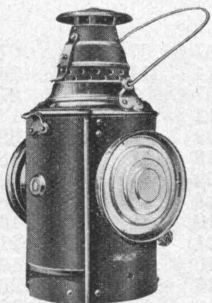

38KZ

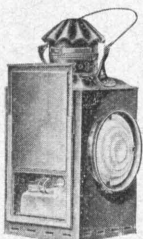

38LA

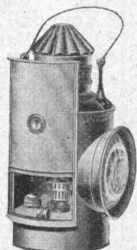

38LB



38LD

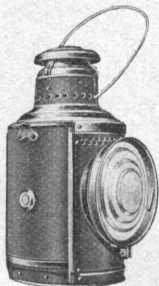

38LE

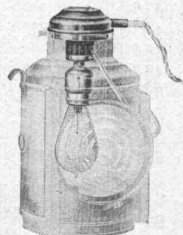

38LF



38LG

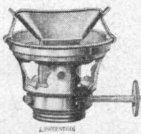

38LH



38LJ



38LK

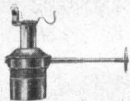

38LL

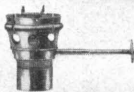

38LM

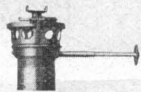

38LN

ORDER No.	38. SEMAPHORE SIGNAL FITTINGS. —Continued.	LIST PRICE		WEIGHT	
				LBS	OZS
38 KZ	Two-arm Block Station Signal Lamp, balanced draught.....	5	25		
38 LA	No. 7 Standard square Semaphore Lamp.....	4	80		
38 LB	No. 8 Standard round Semaphore Lamp.....	4	80		
38 LD	No. 10 Standard Pot Signal Lamp.....	6	75		
38 LE	Steel Semaphore Lamp, top draught.....	6	00		
38 LF	Steel Semaphore Lamp, fitted for Electric Light...	6	50		
38 LG	High Dressel Burner.....		25		
38 LH	Low Dressel Burner.....		20		
38 LJ	Long Burning Fount.....	2	25		
38 LK	Long Burning Fount, fitted with 2-way reflector.....	2	70		
38 LL	No. 1 Long Time Burner for Cylinder Chimney.....	1	25		
38 LM	No. 2 Long Time Burner for Beaded Chimney with Split Spring Gallery Chimney Holder.....	1	50		
38 LN	No. 3 Long Time Burner for Beaded Chimney with Spring Chimney Holder Gallery.....	1	75		

## Types of Bracket Signals

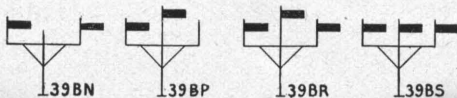
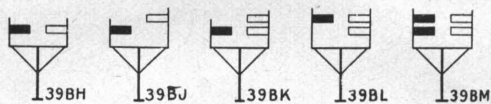
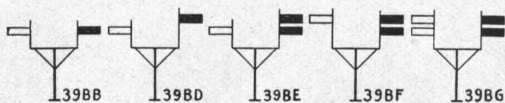
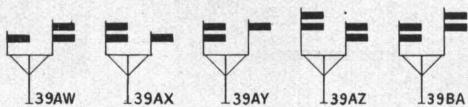
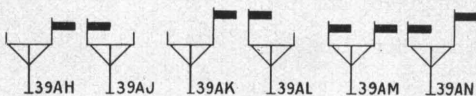
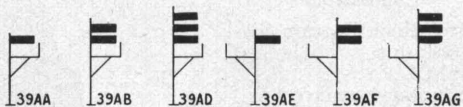

ORDER NO	39. BRACKET SIGNALS.	LIST PRICE	WEIGHT		
			LBS.	OZS	
39 AA	Any type and construction of Bracket Signal, as illustrated by plates of 39-AB, 39-AM, 39-AP, 39-AJ and 39-AX, supplied..... Prices on application Full particulars of requirements should be given when making inquiry.				
to					
39 BS					



## Cantilever Bracket Signal.

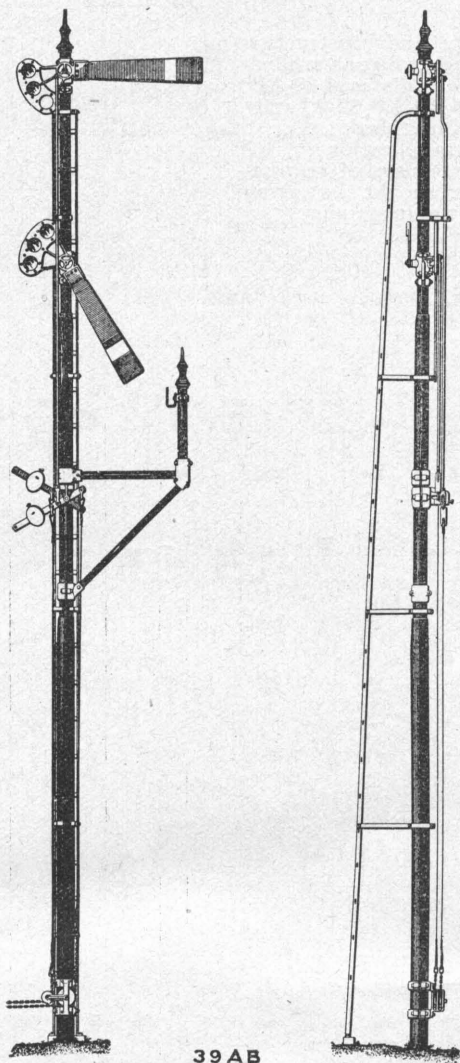

39 AB



STYLE "A" BRACKET SIGNAL.

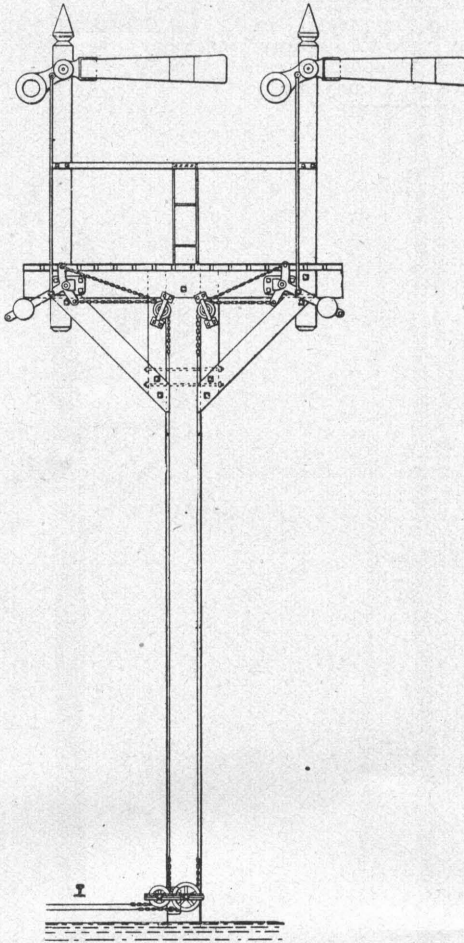

39AM



STYLE "B" BRACKET SIGNAL.

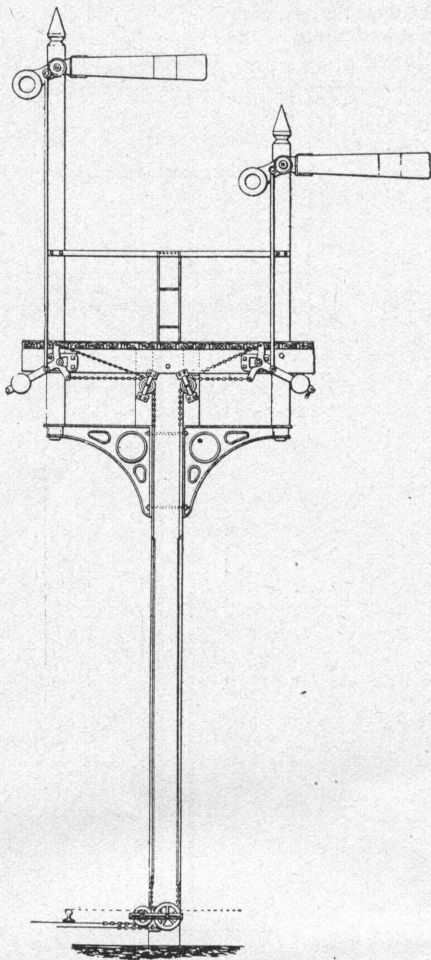

39AP





Style "C" Bracket Signal.

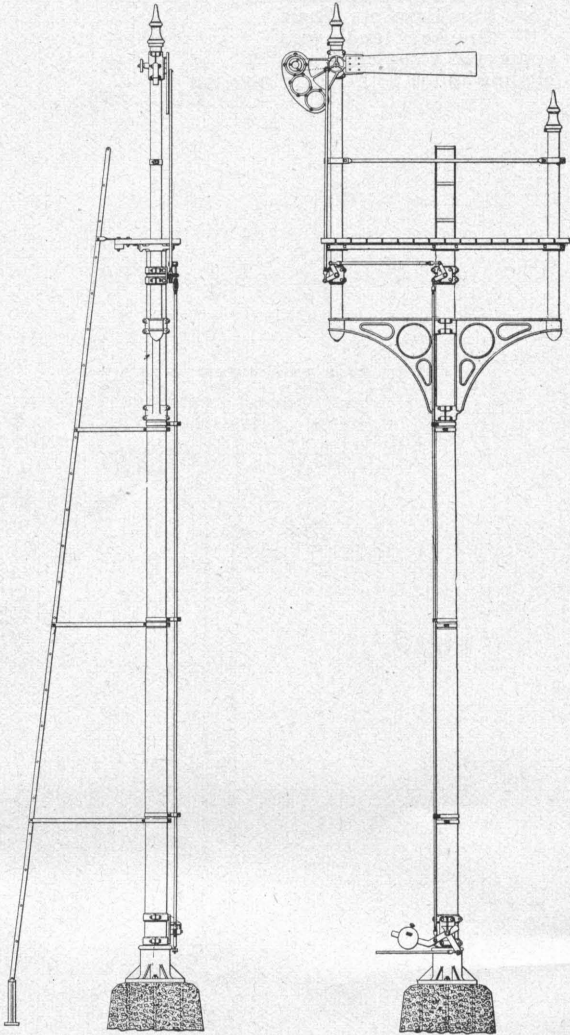

39AJ



Style "D" Bracket Signal.

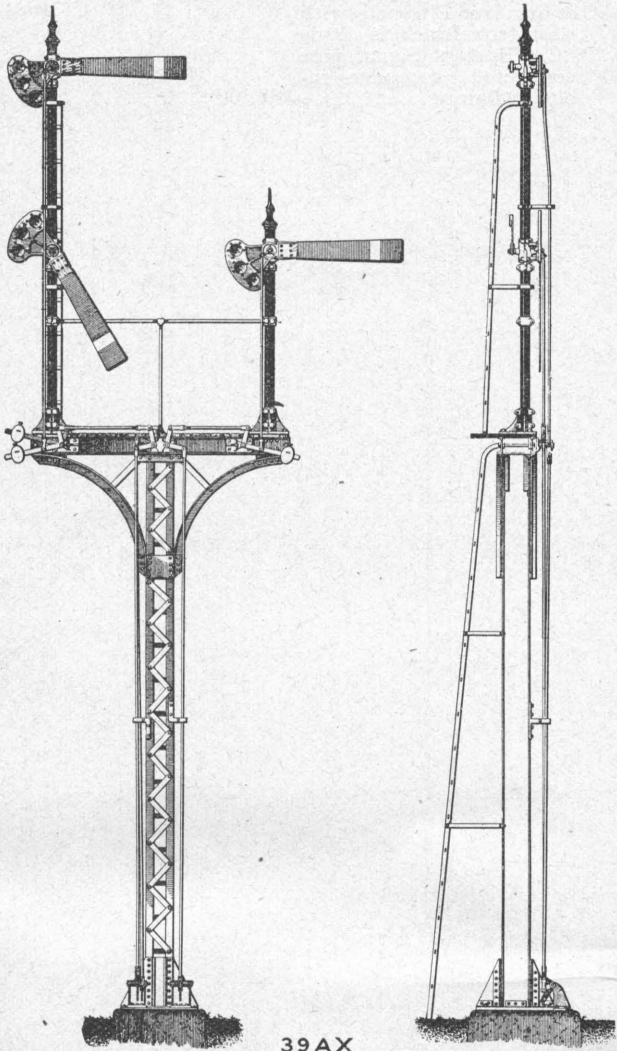

39 AX

ORDER NO.	39. BRACKET SIGNALS —Continued.	LIST PRICE		WEIGHT	
				LBS	OZS
39 AX	Three-arm, Iron Lattice pole Style "D" Bracket Signal, pipe connected complete with lamps.....	388	00		

ONE ARM DWARF SIGNAL.

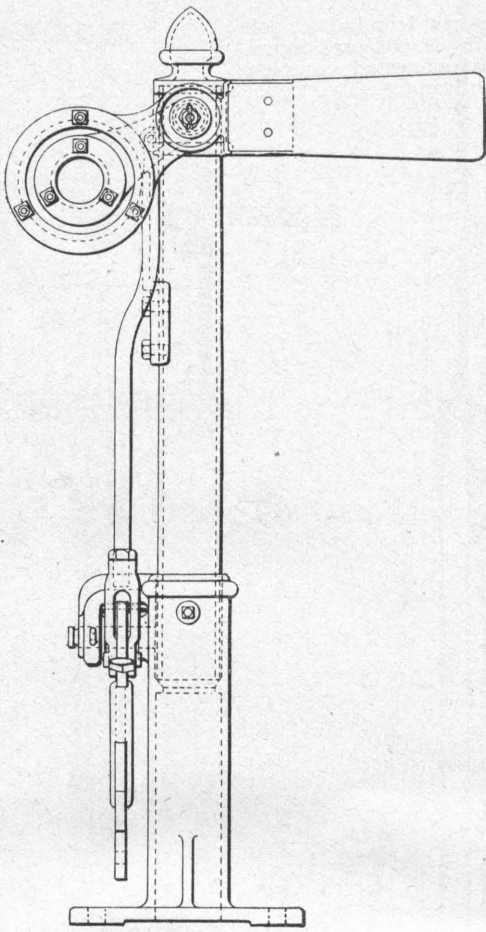

41AA

ORDER No.	41. DWARF SIGNALS.	LIST PRICE		WEIGHT	
				LBS	OZS
41 AA	1 Arm Dwarf Signal, with Lamp complete.....	21	00		
	<b>FITTINGS.</b>				
41 AB	Top Bearing .....		80		
41 AD	2½" Pipe .....	2	70		
41 AE	Stand.....	3	10		
41 AF	Ash Blade.....		12		
41 AG	Blade Grip.....		80		
41 AH	Blade Grip Stud.....		10		
41 AJ	Back Spec.....		50		
41 AK	Spindle.....		84		
41 AL	Down Rod and Screw Jaw.....		65		
41 AM	Balance Lever.....	1	75		
41 AN	1" x 5" Pin.....		12		
38 GW	18 lb. Balance Weight.....	1	15		
41 AP	Lamp Bracket.....		24		
38 JF	3" Blue Glass.....		06		
38 JK	5½" Red Glass.....		54		
38 LB	No. 8 Lamp.....	4	80		



## TWO ARM DWARF SIGNAL.

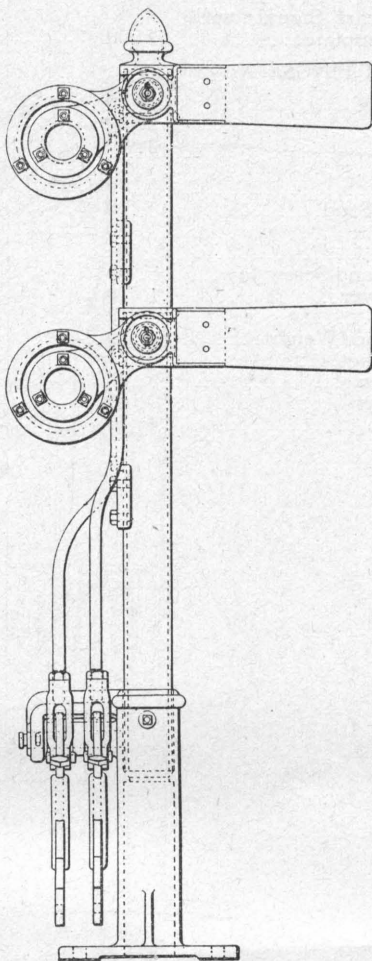

41AR

ORDER No.	41. DWARF SIGNALS.	LIST PRICE	WEIGHT	
			LBS	OZS
41AR	2 Arm Dwarf Signal, with Lamps complete.....	34 00		
	<b>FITTINGS.</b>			
41 AB	Top Bearing.....	80		
41 AS	Centre Bearing.....	70		
41 AT	2½" Pipe.....	3 00		
41 AV	Stand.....	3 50		
41 AF	Ash Blade.....	12		
41 AG	Blade Grip.....	80		
41 AH	Blade Grip Stud.....	10		
41 AJ	Back Spec.....	54		
41 AK	Spindle.....	84		
41 AW	No. 1 Down Rod and Screw Jaw.....	65		
41 AX	No. 2 Down Rod and Screw Jaw.....	85		
41 AM	"L" Balance Lever.....	1 75		
41 AY	1" x 7" Pin.....	16		
38 GW	18 lb. Balance Weight.....	1 15		
41 AP	Lamp Bracket.....	24		
38 JF	3" Blue Glass.....	06		
38 JZ	5½" Red Glass.....	54		
38 LB	No. 8 Lamp.....	4 80		

## STYLE "1" COMPENSATING DWARF SIGNAL.

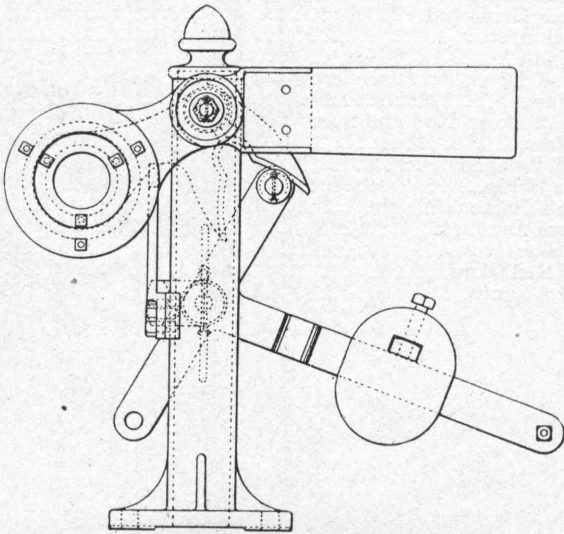

42AA

ORDER NO.	42. COMPENSATING DWARF SIGNALS.	LIST PRICE		WEIGHT	
				LBS	OZS
42 AA	Style "1" Dwarf Signal, 18" High, with Lamp complete	17	00		
	<b>FITTINGS.</b>				
42 AB	Stand .....	3	75		
41 AF	Ash Blade .....		12		
42 AD	Blade Grip .....		80		
42 AE	Escapement Back Spec. ....	1	00		
42 AF	Spindle .....		84		
42 AG	"T" Balance Lever, Stud and Roller .....	4	00		
42 AH	"T" Balance Lever Stud ..		20		
42 AJ	Roller .....		15		
42 AK	$\frac{7}{8}$ " x 4" Pin .....		12		
38 GS	10 lb. Balance Weight .....		70		
42 AL	Lamp Bracket .....		24		
38 JF	3" Blue Glass .....		06		
38 JZ	5 $\frac{1}{2}$ " Red Glass .....		54		
38 LB	No. 8 Lamp .....	4	80		

STYLE "2" COMPENSATING DWARF SIGNAL.

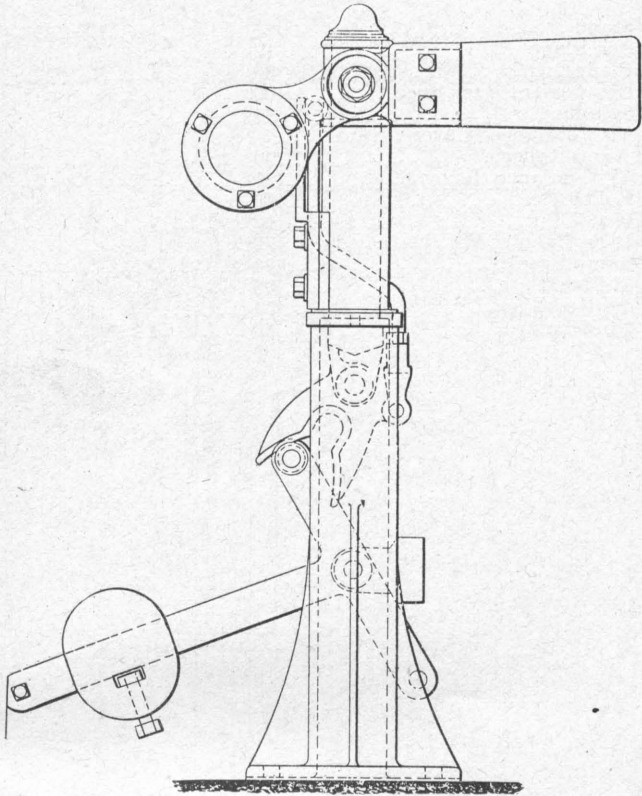

42AN

ORDER NO.	42. COMPENSATING DWARF SIGNALS	LIST PRICE		WEIGHT	
				LBS	OZS
42 AN	Style "2" Dwarf Signal, 2' 9" High, with Lamp complete.....	20	00		
	<b>FITTINGS</b>				
42 AP	Stand.....	4	75		
41 AF	Ash Blade.....		12		
42 AD	Blade Grip.....		80		
42 AR	Back Spec, with Stud.....		50		
42 AS	Back Spec, Stud.....		15		
42 AT	Spindle.....		84		
42 AV	Escapement Crank.....	1	00		
42 AW	Down Rod and Screw Jaw....		65		
42 AX	"T" Balance Lever, Stud and Roller.....	4	00		
42 AH	"T" Balance Lever Stud....		20		
42 AJ	"T" Balance Lever, Roller		15		
42 AK	7" x 4" Pin.....		12		
38 GW	18 lb. Balance Weight.....	1	15		
42 AY	Lamp Bracket.....		24		
38 JF	3" Blue Glass.....		06		
38 JZ	5½" Red Glass.....		54		
38 LB	No. 8 Lamp.....	4	80		



STYLE "3" COMPENSATING DWARF SIGNAL.

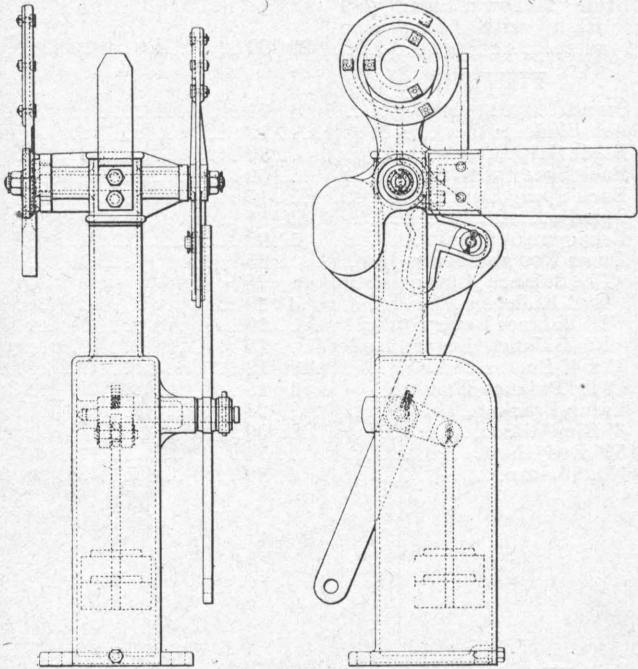

42BB

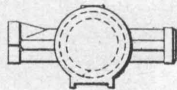

42BH

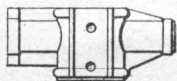

ORDER NO.	42. COMPENSATING DWARF SIGNALS.	LIST PRICE		WEIGHT	
				LBS	OZS
42 BA	Style "3" Dwarf Signal, 18" High, with Lamp complete	17	50		
42 BB	Style "3" Dwarf Signal, 2' 3" High, with Lamp complete.....	18	50		
<b>FITTINGS.</b>					
42 BD	18" Stand.....	4	50		
42 BE	18" Stand Cover.....		75		
42 BF	2' 3" Stand.....	5	00		
42 BG	2' 3" Stand Cover.....		75		
42 BH	Head.....	2	50		
42 AF	Ash Blade.....		12		
42 BJ	Blade Grip.....		80		
42 BK	Escapement Back Spec (Low).....	1	25		
42 BL	Escapement Back Spec (High).....	1	25		
42 BM	Spindle.....		84		
42 BN	Balance Lever, with Stud and Roller (Low).....	2	50		
42 BP	Balance Lever, with Stud and Roller (High).....	2	50		
42 BR	7/8" x 9" Pin.....		20		
42 BS	3" Crank.....		25		
42 BT	Drop Weight, with Eye Rod.....		50		
42 BV	Drop Weight.....		30		
42 BW	Lamp Bracket.....	4	80		

Dwarf Signal With Spring Attachment.

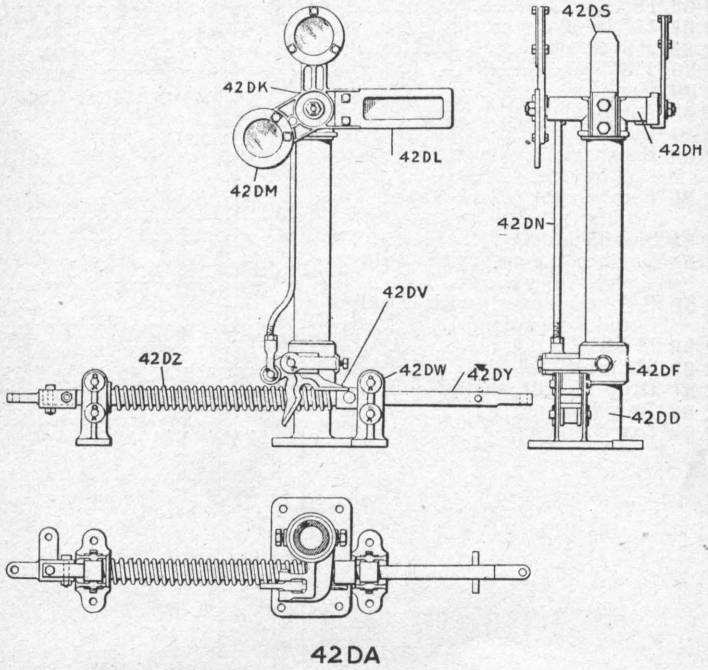

ORDER No.	DWARF SIGNALS WITH SPRING ATTACH- MENT.	LIST PRICE		WEIGHT	
				LBS	OZS
42 DA	1-arm Signal complete.....	18	50		
42 DB	2-arm Signal complete.....	35	00		
42 DD	Stand for 1-arm.....	1	90		
42 DE	Stand for 2-arm.....	3	00		
42 DF	1-way Crank Bearing and Pin and Tap Bolt.....		90		
42 DG	2-way Crank Bearing and Pin and Tap Bolt.....	1	00		
42 DH	Semaphore Bearing and Tap Bolts.....		95		
42 DJ	Upper Semaphore Bearing and Pinnacle with Tap Bolts for 2-arm Signal....	1	15		
42 DK	Semaphore Spindle com- plete with Nuts.....		80		
42 DL	Rubber Blade with Clip, Plate and Bolts.....		50		
42 DM	Rubber Disc with Clip Plate and Bolts.....		40		

### Dwarf Signal with Spring Attachment.

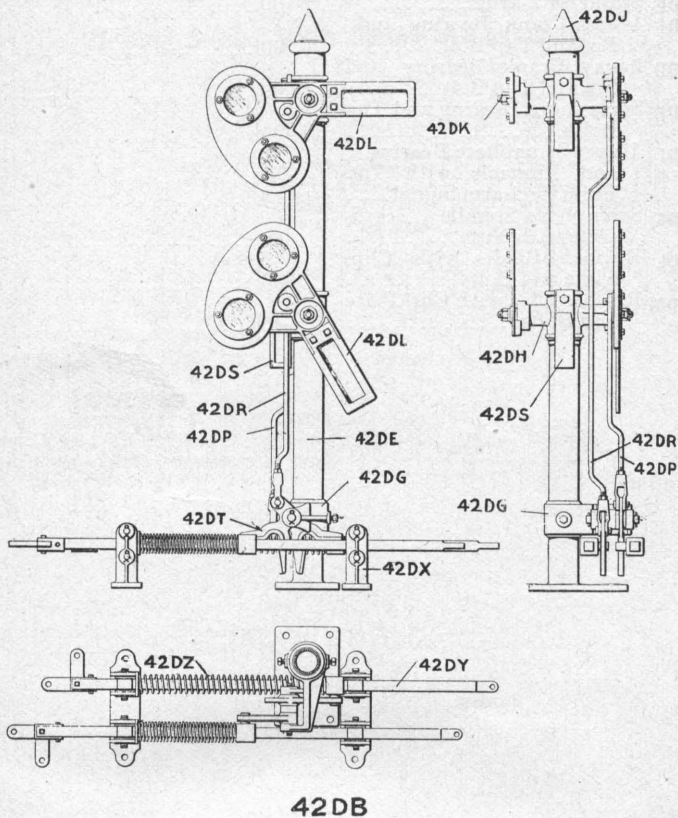

ORDER NO.	DWARF SIGNAL WITH SPRING ATTACHMENT Cont'd.	LIST PRICE	WEIGHT	
			LBS	OZS
42DN	Up and Down Rod, with eye, Screw Jaw and Pin complete for 1-arm.....	55		
42DP	Ditto for Lower arm, 2-arm Signal.....	60		
42DR	Ditto for Upper arm, 2-arm Signal.....	65		
42DS	Lamp Bracket for 1-arm Signal and Tap Bolts.....	27		
42DT	Lamp Bracket for 2-arm Signal and Tap Bolts.....	35		
42DV	Escapement Crank.....	27		
42DW	1-way Guide Stand complete.....	85		
42DX	2-way Guide Stand complete	1 65		
42DY	Operating shaft complete with Trunnion and Spring Plate.....	1 15		
42DZ	Operating Spring.....	40		
42EA	Torsion Spring and Block.....	35		



## Dwarf Signal Fittings

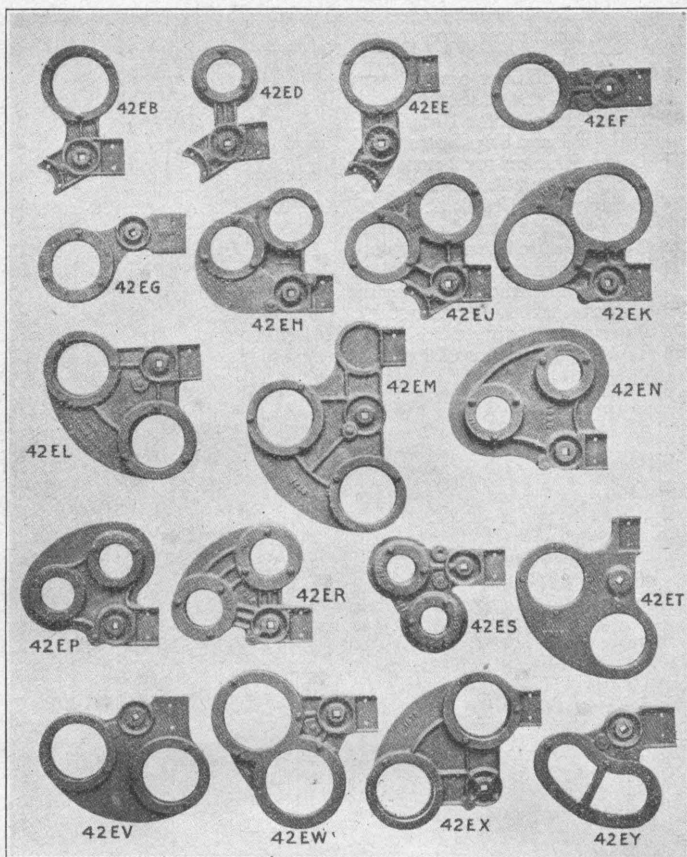

ORDER NO.	42. DWARF SIGNAL FITTINGS.	LIST PRICE	WEIGHT	
			LBS	OZS
42 EB	Two-position, one-light, 60° Blade-grip complete excepting glass.....	75		
42 ED	Two-position, one-light, 60° Blade-grip complete excepting glass.....	80		
42 EE	Two-position, one-light, 90° Blade-grip complete excepting glass.....	75		
42 EF	Two-position, one-light, 60° Blade-grip complete excepting glass.....	80		
42 EG	Two-position, one-light, 60° Blade-grip complete excepting glass.....	80		
42 EH	Two-position, two-light, 60° Blade-grip complete excepting glass.....	1 20		
42 EJ	Two-position, two-light, 60° Blade-grip complete excepting glass.....	1 15		
42 EK	Two-position, two-light, 60° Blade grip complete excepting glass.....	1 25		
42 EL	Two-position, two-light, 90° Blade-grip complete excepting glass.....	1 10		
42 EM	Two-position, two-light, 90° Blade-grip complete excepting glass.....	1 20		
42 EN	Two-position, two-light, 60° Blade-grip complete excepting glass.....	1 15		
42 EP	Two-position, two-light, 60° Blade-grip complete excepting glass.....	1 00		
42 ER	Two-position, two-light, 75° Blade-grip complete excepting glass.....	1 10		
42 ES	Two-position, two-light, 60° Blade-grip complete excepting glass.....	1 05		
42 ET	Two-position, two-light, 90° Blade-grip complete excepting glass.....	1 85		
42 EV	Two-position, two-light, 90° Blade-grip complete excepting glass.....	1 10		

ORDER No.	42. DWARF SIGNAL FITTINGS.—Cont.	LIST PRICE	WEIGHT	
			LBS	OZS
42 EW	Two-position, two-light, 60° Blade-grip complete excepting glass.....	1 05		
42 EX	Two-position, two-light, 90° Blade-grip complete excepting glass.....	1 20		
42 EY	Two-position, two-light, 60° Blade-grip complete excepting glass.....	1 00		



POT SIGNAL.

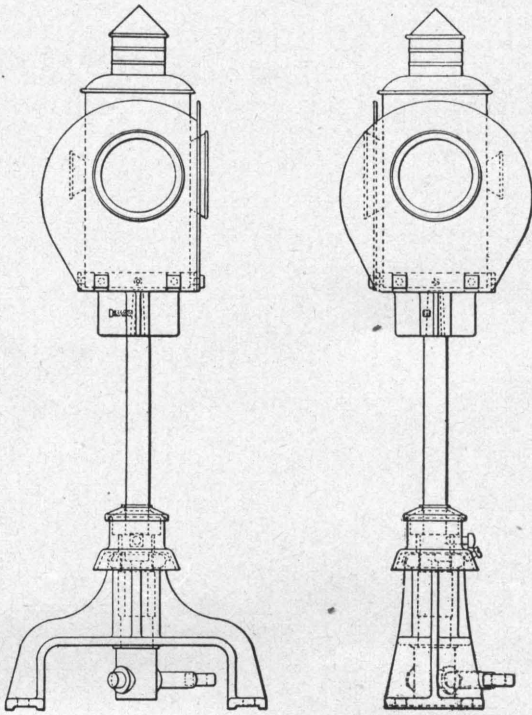

43AA

ORDER No.	43. POT SIGNALS. Pipe Connected.	LIST PRICE	WEIGHT	
			LBS	OZS
43 AA	Pot Signal 2' 9" High, with Lamp complete.....	15 00		
<b>FITTINGS</b>				
43 AB	Stand.....	2 00		
43 AD	Vertical Shaft and Lamp Socket.....	2 75		
43 AE	Adjustable Crank.....	54		
43 AF	Top Bearing Bush.....	45		
43 AG	Cover.....	10		
43 AH	Red Target.....	70		
43 AJ	White Target.....	70		
43 AK	Lamp Base.....	80		
38 LD	No. 10 Lamp.....	6 75		



HIGH POT SIGNAL.

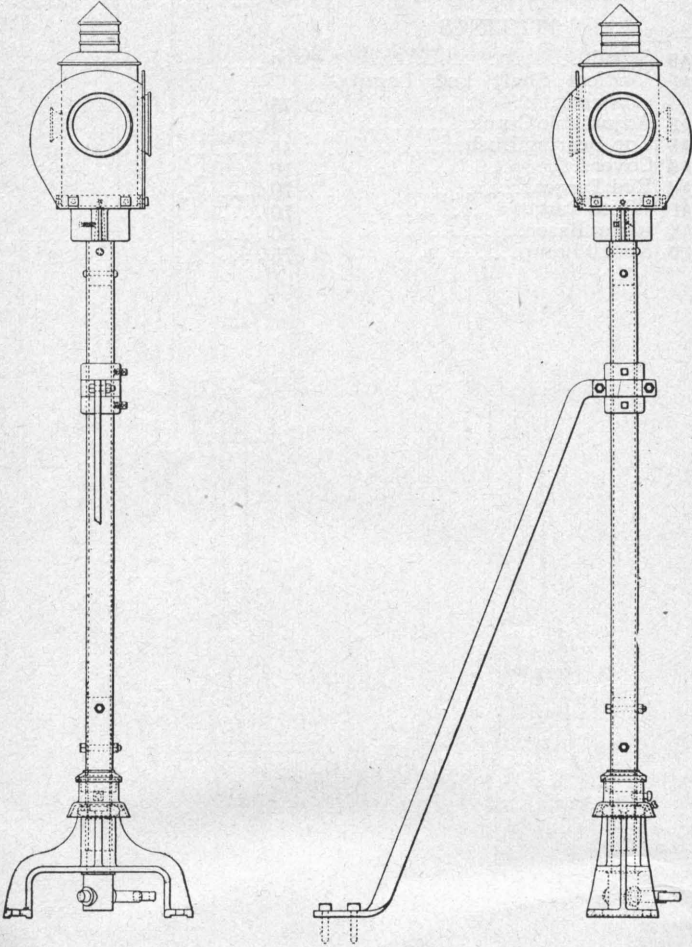

43AL

ORDER NO.	43. POT SIGNALS. Pipe Connected.	LIST PRICE	WEIGHT	
			LBS	OZS
43 AL	Pot Signal 6' 0" High, with Lamp complete.....	20 00		
<b>FITTINGS.</b>				
43 AM	Stand.....	3 00		
43 AN	2" Pipe Socket and Crank Bush.....	4 50		
43 AP	Top Bearing Bush.....	54		
43 AR	Cover.....	25		
43 AS	2" Pipe.....	1 00		
43 AT	Stay Rod.....	1 00		
43 AV	Stay Collar.....	50		
43 AH	Red Target.....	70		
43 AJ	White Target.....	70		
43 AK	Lamp Base.....	80		
43 AW	Lamp Socket.....	25		
38 LD	No. 10 Lamp.....	6 75		

**SELECTOR.**  
Pipe Connected.

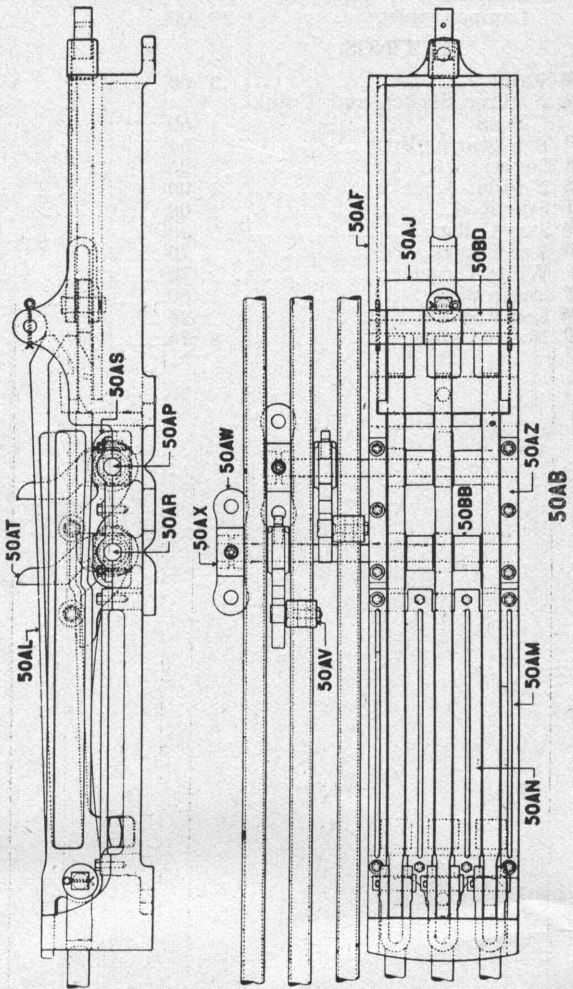

ORDER No.	50. SELECTORS. Pipe Connected.	LIST PRICE		WEIGHT	
				LBS	OZS
50 AA	2 Hook Selector complete...	14	25		
50 AB	3 " " " .....	20	25		
50 AD	4 " " " .....	27	00		
<b>FITTINGS.</b>					
50 AE	2 Hook Stand.....	4	25		
50 AF	3 " " .....	4	85		
50 AG	4 " " .....	5	85		
50 AH	2 " Slide.....		45		
50 AJ	3 " " .....		75		
50 AK	4 " " .....	1	05		
50 AL	Selector Hook.....	1	00		
50 AM	Side Guide Bar.....		65		
50 AN	Centre Guide Bar.....		60		
50 AP	No. 1 Shaft.....		95		
50 AR	No. 2 Shaft.....	1	00		
50 AS	Cam.....		09		
50 AT	Escapement Crank.....		35		
50 AV	Clamp Stud.....		24		
50 AW	End Bearing.....		12		
50 AX	End Bearing Bush.....		20		
50 AY	No. 1 Bearing Cap.....		09		
50 AZ	No. 2 " " .....		12		
50 BA	No. 3 " " .....		18		
50 BB	1½" x 2" Collar.....		09		
50 BD	2" x 2½" Roller.....		20		

SELECTOR.  
Wire Connected.

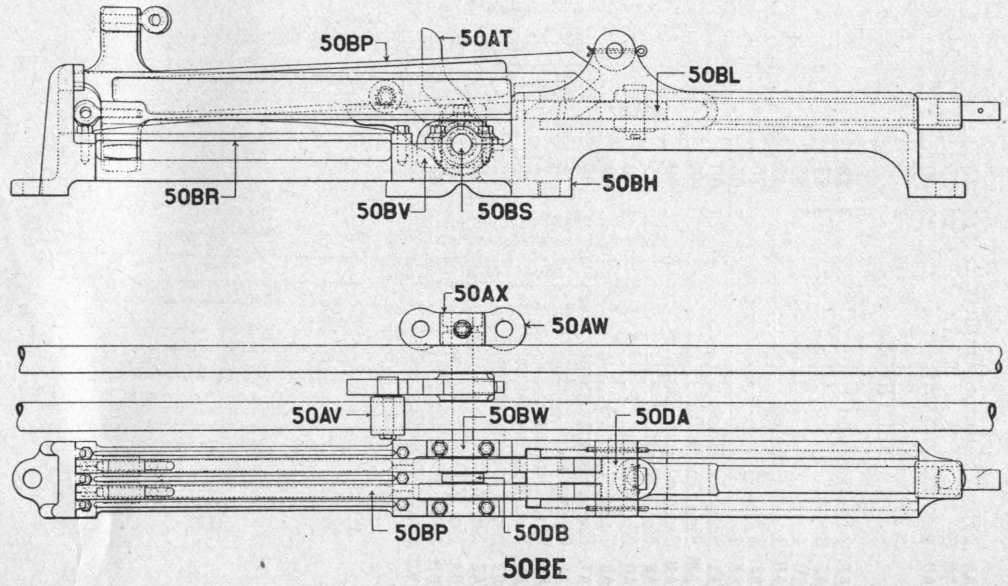

ORDER NO.	50. SELECTORS. Wire Connected.	LIST PRICE		WEIGHT	
				LBS	OZS
50 BE	2 Hook Selector complete . . .	12	25		
50 BF	3 " " " . . .	16	50		
50 BG	4 " " " . . .	21	25		
<b>FITTINGS.</b>					
50 BH	2 Hook Stand . . . . .	4	75		
50 BJ	3 " " . . . . .	5	50		
50 BK	4 " " . . . . .	6	25		
50 BL	2 " Slide . . . . .		36		
50 BM	3 " " . . . . .		48		
50 BN	4 " " . . . . .		60		
50 BP	Selector Hook . . . . .	1	50		
50 BR	Guide Bar . . . . .		65		
50 BS	No. 1 Shaft . . . . .		95		
50 BT	No. 2 Shaft . . . . .	1	00		
50 BV	Cam . . . . .		09		
50 AT	Escapement Crank . . . . .		35		
50 AV	Clamp Stud . . . . .		24		
50 AW	End Bearing . . . . .		12		
50 AX	End Bearing Bush . . . . .		20		
50 BW	No. 1 Bearing Cap . . . . .		09		
50 BX	No. 2 " Cap . . . . .		12		
50 BZ	No. 3 " Cap . . . . .		18		
50 DA	2" x 2" Roller . . . . .		20		
50 BD	$\frac{3}{8}$ " x 2" Collar . . . . .		08		



SIGNAL SLOTS.

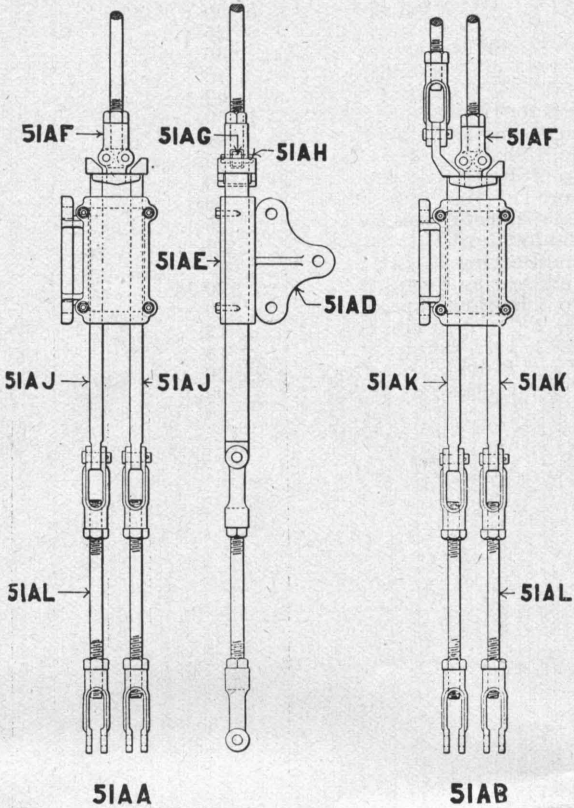

ORDER No.	51. SIGNAL SLOTS.	LIST PRICE	WEIGHT				
			LBS	OZS			
51 AA	1 Arm Signal Slot, complete.	9 70					
51 AB	"Home" and "Distant" Signal Slot, complete..... (Top Arm controlling Lower Distant Arm.)	10 85					
<b>FITTINGS</b>							
51 AD	Slot Stand. ....	1 05					
51 AE	Cover and Tap Bolts.....	45					
51 AF	Swing Jaw, with Steel Rollers, Pins and $\frac{3}{4}$ " Screw End	2 00					
51 AG	$\frac{3}{8}$ " x $1\frac{1}{8}$ " Steel Roller.....	36					
51 AH	$\frac{3}{8}$ " x 2" Pin. ....	03					
51 AJ	No. 1 Vertical Slide.....	1 80					
51 AK	No. 2 Vertical Slide for Lower Distant Slot. ....	2 90					
51 AL	Coupling Rod, with two $\frac{3}{4}$ " Screw Jaws.....	1 05					

DISTANT SIGNAL WITH WIRE COMPENSATOR

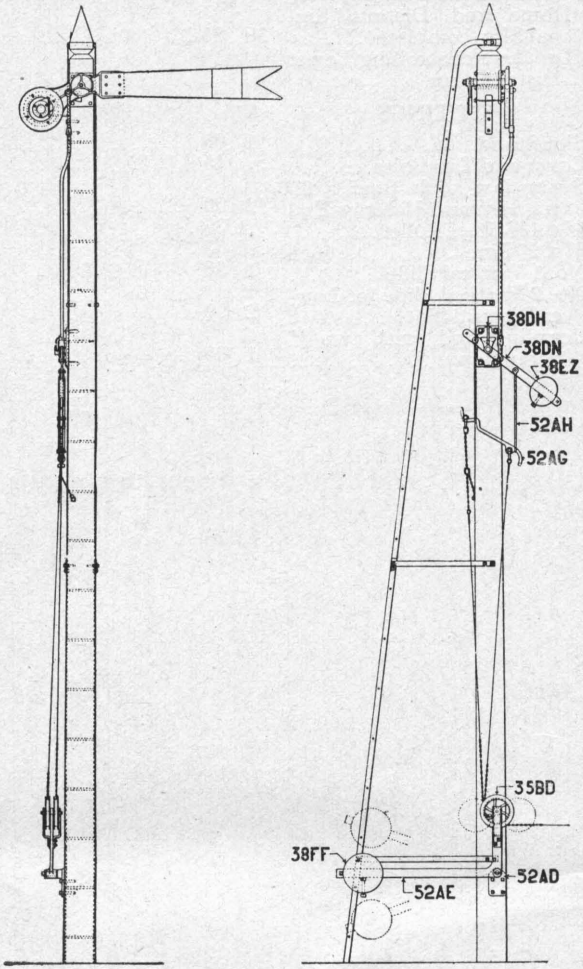

52AA

ORDER No.	52. WIRE COMPENSATORS.	LIST PRICE		WEIGHT	
				LBS	OZS
52 AA	1 Arm Distant Signal 32 ft. post with Mechanical Wire Compensator and all Fittings complete.....	81	50		
52 AB	1 Arm Mechanical Wire Compensator complete, including Compensating Lever, Stand, two 10" Wheels, one 100 lbs. Balance Weight, one Balance Lever, Stand, and 18 lbs Weight, one Disengaging Lever, two 24" Links.....	24	00		
<b>FITTINGS.</b>					
52 AD	Compensator Stand.....	1	40		
52 AE	1 1/4" Pin.....		18		
52 AF	Compensating Lever.....	10	00		
35 BD	10" Wheel.....		36		
38 HB	100 lbs. Balance Weight.....	4	90		
52 AG	Disengaging Lever.....		85		
52 AH	24" Link and Pin.....		60		
38 GM	1 Way Balance Lever Stand with Pin.....	1	25		
38 GB	Balance Lever.....	1	25		
38 GW	18 lbs. Weight.....	1	15		

WIRE PULLEYS.



53AB

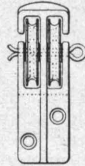

53AD

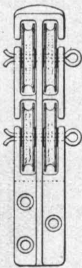

53AE

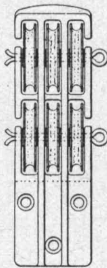

53AF

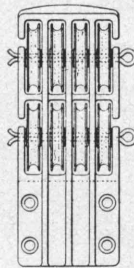

53AG

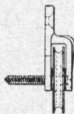
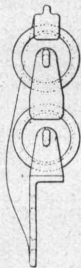

53AH

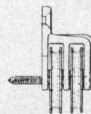

53AJ



53AK

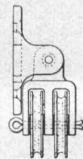
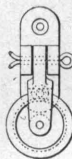

53AL

ORDER No.	53. WIRE PULLEYS.	LIST PRICE	WEIGHT	
			LBS	OZS
53 AA	1-way Wire Pulley.....	07		
53 AB	2-way Wire Pulley N. Y., N. H., & H. R. R.....	12		
53 AD	2-way Wire Pulley.....	12		
53 AE	4-way Wire Pulley.....	21		
53 AF	6-way Wire Pulley.....	27		
53 AG	8-way Wire Pulley.....	36		
53 AH	1-way Side Wire Pulley.....	07		
53 AJ	2-way Side Wire Pulley.....	11		
53 AK	1-way Angle Wire Pulley...	12		
53 AL	2-way Angle Wire Pulley.....	20		

NOTE.—Wire Pulley Stand  
53AB can be placed side  
by side, making any num-  
ber of ways required, and  
bolted together.



Wire and Connections.



53AL



53AM



53AN



53AP

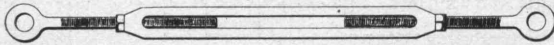

53AZ

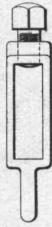

53AX



53AS



53AR



53BA

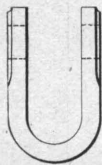

53AW



53AV



53AT

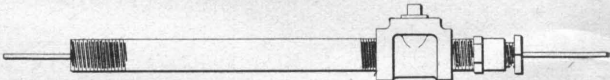

53BB

ORDER No.	53. WIRE AND CONNECTIONS.	LIST PRICE		WEIGHT	
				LBS	OZS
53 AL	No. 9 Galvanized Steel Signal Wire, per 100 ft. . . . .	54			
53 AM	7 Strand Steel Signal Wire per 100 ft. . . . .	1 00			
53 AN	Wire Eyes (Oval) . . . . .	06			
53 AP	Steel Split Links . . . . .	02			
53 AR	$\frac{5}{8}$ " Malleable Shackles and Pin . . . . .	10			
53 AS	$\frac{7}{8}$ " Malleable Shackles and Pin . . . . .	10			
53 AT	$\frac{5}{8}$ " Malleable Double Shackle and Pin . . . . .	12			
53 AV	$\frac{7}{8}$ " Malleable Double Shackle and Pin . . . . .	15			
53 AW	Malleable Wide Shackle and Pin . . . . .	12			
53 AX	Adjustable Connectors . . . . .	35			
53 AZ	Wire Adjusting Screw . . . . .	90			
53 BA	$\frac{1}{4}$ " Proof Chain, per ft. . . . .	12			
53 BB	Wrigley Stuffing Box, no Pipe . . . . .	75			

## STYLE "A" FOUNDATIONS.



57AA

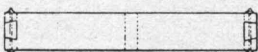
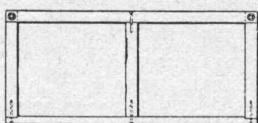

57AT

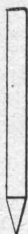

57BG

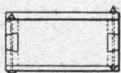
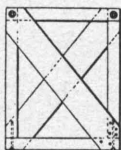

57AZ

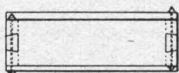
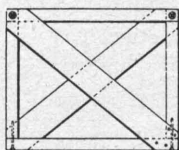

57BA

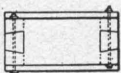

57BE

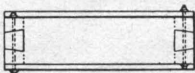
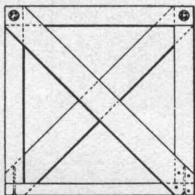

57BF



57BH

ORDER No.	57. STYLE "A" FOUNDATIONS.	LIST PRICE	WEIGHT			
			LBS			
57 AA	1-way Pipe Carrier Foundation.....	75				
57 AB	2-way Pipe Carrier Foundation.....	79				
57 AD	3-way Pipe Carrier Foundation.....	83				
57 AE	4-way Pipe Carrier Foundation.....	87				
57 AF	5-way Pipe Carrier Foundation.....	91				
57 AG	6-way Pipe Carrier Foundation.....	95				
57 AH	7-way Pipe Carrier Foundation.....	99				
57 AJ	8-way Pipe Carrier Foundation.....	1 03				
57 AK	9-way Pipe Carrier Foundation.....	1 07				
57 AL	10-way Pipe Carrier Foundation.....	1 11				
57 AM	11-way Pipe Carrier Foundation.....	1 15				
57 AN	12-way Pipe Carrier Foundation.....	1 19				
57 AP	13-way Pipe Carrier Foundation.....	1 40				
57 AR	14-way Pipe Carrier Foundation.....	1 45				
57 AS	15-way Pipe Carrier Foundation.....	1 50				
57 AT	16-way Pipe Carrier Foundation.....	1 55				
57 AV	17-way Pipe Carrier Foundation.....	1 60				
57 AW	18-way Pipe Carrier Foundation.....	1 65				
57 AX	19-way Pipe Carrier Foundation.....	1 70				
57 AY	20-way Pipe Carrier Foundation.....	1 75				
57 AZ	Wheel Foundation 2' 0" Top.....	1 85				
57 BA	Wheel Foundation 3' 0" Top.....	1 95				
57 BB	Wheel Foundation 4' 0" Top.....	2 05				
57 BD	Dwarf Signal Foundation.....	2 34				
57 BE	Crank Foundation.....	2 90				
57 BF	Compensator Foundation.....	3 10				
57 BG	3" x 4" x 4' 0" Oak Stakes for Wire Pulleys.....	23				
57 BH	3" x 4" x 5' 0" Oak Stakes for Wire Pulleys.....	30				

## STYLE "C" FOUNDATIONS.

Wood Tops and Sills, Iron Up-Rights and Braces.

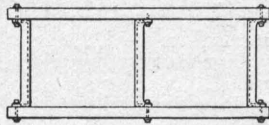
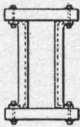

57DP

57EJ

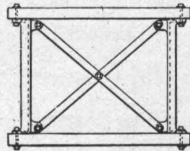
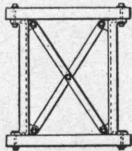

57EP

57ES

ORDER NO.	57. STYLE "C" FOUNDATIONS.	LIST PRICE		WEIGHT	
				LBS	OZS
57 DP	1-way Pipe Carrier Foundation.....	2	24		
57 DR	2-way Pipe Carrier Foundation.....	2	26		
57 DS	3-way Pipe Carrier Foundation.....	2	28		
57 DT	4-way Pipe Carrier Foundation.....	2	30		
57 DV	5-way Pipe Carrier Foundation.....	2	32		
57 DW	6-way Pipe Carrier Foundation.....	2	34		
57 DX	7-way Pipe Carrier Foundation.....	2	36		
57 DY	8-way Pipe Carrier Foundation.....	2	38		
57 DZ	9-way Pipe Carrier Foundation.....	2	40		
57 EA	10-way Pipe Carrier Foundation.....	2	42		
57 EB	11-way Pipe Carrier Foundation.....	2	44		
57 ED	12-way Pipe Carrier Foundation.....	2	46		
57 EF	13-way Pipe Carrier Foundation.....	2	48		
57 EG	14-way Pipe Carrier Foundation.....	2	50		
57 EH	15-way Pipe Carrier Foundation.....	2	52		
57 EJ	16-way Pipe Carrier Foundation.....	3	58		
57 EK	17-way Pipe Carrier Foundation.....	3	60		
57 EL	18-way Pipe Carrier Foundation.....	3	62		
57 EM	19-way Pipe Carrier Foundation.....	3	64		
57 EN	20-way Pipe Carrier Foundation.....	3	66		
57 EP	Wheel Foundation 2' 0" Top.....	4	75		
57 ER	Wheel Foundation 3' 0" Top.....	5	00		
57 ES	Wheel Foundation 4' 0" Top.....	5	25		
57 ET	Dwarf Signal Foundation.....	5	75		
57 EV	Crank Foundation.....	5	00		
57 EW	Compensator Foundation.....	6	25		



## Style "D" Foundations.

WAY	LENGTH OF TOP	No. OF PIERS
57FA	1'- 0''	1
57FB	1'- 2 $\frac{3}{4}$ ''	1
57FD	1'- 5 $\frac{1}{2}$ ''	1
57FE	1'- 8 $\frac{1}{2}$ ''	1
57FF	2'- 0''	2
57FG	2'- 0''	2
57FH	2'- 4 $\frac{1}{2}$ ''	2
57FJ	2'- 7 $\frac{1}{2}$ ''	2
57FK	2'- 10''	2
57FL	3'- 0 $\frac{3}{4}$ ''	2
57FM	3'- 3 $\frac{1}{2}$ ''	2
57FN	3'- 6 $\frac{1}{4}$ ''	2
57FP	3'- 9''	2
57FR	3'- 11 $\frac{3}{4}$ ''	2
57FS	4'- 2 $\frac{1}{2}$ ''	2
57FT	4'- 5 $\frac{1}{4}$ ''	2
57FV	4'- 8''	3
57FW	4'- 10 $\frac{3}{4}$ ''	3
57FX	5'- 1 $\frac{1}{2}$ ''	3
57FY	5'- 4 $\frac{1}{4}$ ''	3
57FZ	5'- 7''	3
57GA	5'- 9 $\frac{3}{4}$ ''	3
57GB	6'- 0 $\frac{1}{2}$ ''	3
57GD	6'- 3 $\frac{1}{4}$ ''	3
57GE	6'- 6''	3
57GF	6'- 8 $\frac{3}{4}$ ''	3
57GG	6'- 11 $\frac{1}{2}$ ''	3
57GH	7'- 2 $\frac{1}{4}$ ''	3
57GJ	7'- 5''	3
57GK	7'- 7 $\frac{3}{4}$ ''	3

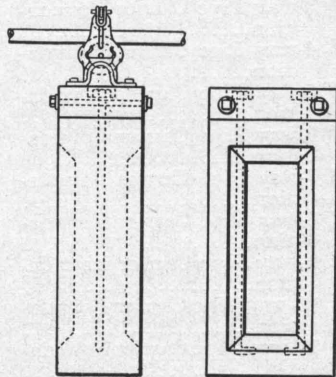

57FA

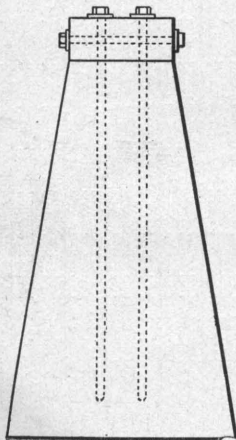

57GL

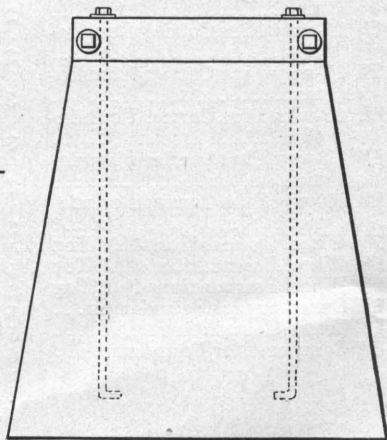

ORDER No.	57. STYLE "D" FOUNDATIONS.	LIST PRICE	WEIGHT	
			LBS	OZS
57 FA	Top and Bolts only for 1-way Pipe Carrier Foundation.....	79		
57 FB	Top and Bolts only for 2-way Pipe Carrier Foundation.....	82		
57 FD	Top and Bolts only for 3-way Pipe Carrier Foundation.....	85		
57 FE	Top and Bolts only for 4-way Pipe Carrier Foundation.....	88		
57 FF	Top and Bolts only for 5-way Pipe Carrier Foundation.....	1 27		
57 FG	Top and Bolts only for 6-way Pipe Carrier Foundation.....	1 30		
57 FH	Top and Bolts only for 7-way Pipe Carrier Foundation.....	1 33		
57 FJ	Top and Bolts only for 8-way Pipe Carrier Foundation.....	1 36		
57 FK	Top and Bolts only for 9-way Pipe Carrier Foundation.....	1 39		
57 FL	Top and Bolts only for 10-way Pipe Carrier Foundation.....	1 42		
57 FM	Top and Bolts only for 11-way Pipe Carrier Foundation.....	1 45		
57 FN	Top and Bolts only for 12-way Pipe Carrier Foundation.....	1 48		
57 FP	Tops and Bolts only for 13-way Pipe Carrier Foundation.....	1 51		
57 FR	Top and Bolts only for 14-way Pipe Carrier Foundation.....	1 54		
57 FS	Top and Bolts only for 15-way Pipe Carrier Foundation.....	1 57		
57 FT	Top and Bolts only for 16-way Pipe Carrier Foundation.....	1 60		

ORDER NO.	57. STYLE "D" FOUNDATIONS.	LIST PRICE	WEIGHT	
			LBS	OZS
57 FV	Top and Bolts only for 17-way Pipe Carrier Foundation.....	2 05		
57 FW	Top and Bolts only for 18-way pipe Carrier Foundation.....	2 08		
57 FX	Top and Bolts only for 19-way Pipe Carrier Foundation.....	2 11		
57 FY	Top and Bolts only for 20-way Pipe Carrier Foundation.....	2 14		
57 FZ	Top and Bolts only for 21-way pipe Carrier Foundation .....	2 17		
57 GA	Top and Bolts only for 22-way Pipe Carrier Foundation.....	2 20		
57 GB	Top and Bolts only for 23-way Pipe Carrier Foundation.....	2 23		
57 GD	Top and Bolts only for 24-way Pipe Carrier Foundation.....	2 26		
27 GE	Top and Bolts only for 25-way Pipe Carrier Foundation.....	2 29		
57 GF	Top and Bolts only for 26-way Pipe Carrier Foundation.....	2 32		
57 GG	Top and Bolts only for 27-way Pipe Carrier Foundation.....	2 35		
57 GH	Top and Bolts only for 28-way Pipe Carrier Foundation.....	2 38		
57 GJ	Top and Bolts only for 29-way Pipe Carrier Foundation.....	2 41		
57 GK	Top and Bolts only for 30-way Pipe Carrier Foundation.....	2 44		
57 GL	Top and Bolts only for Crank or Wheel Foundation.....	2 00		
57 GM	Top and Bolts only for Compensator Foundations	2 30		
57 GN	Top and Bolts only for Dwarf Signal or Selector Foundation.....	2 60		



STYLE "O" SIGNAL TOWER.

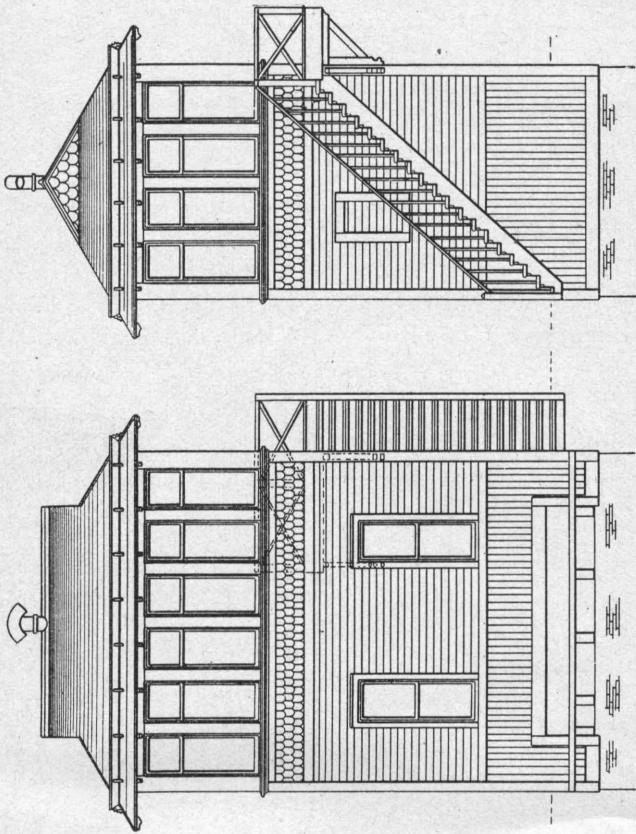

62AD

ORDER NO.	62. SIGNAL TOWERS.	LIST PRICE	WEIGHT		
			LBS	OZS	
	Style "O" Signal Towers, 12 0" Wide.....				
62 AA	8 to 16 Levers, 12' 0" Long				
62 AB	20 to 24 Levers, 14' 8½" Long				
62 AD	28 Levers, 17' 5" Long.....				
62 AE	32 to 36 Levers, 20' 1½" Long				
62 AF	40 to 44 Levers, 23' 3" Long				
62 AG	48 to 52 Levers, 26' 4½" Long				
62 AH	56 Levers, 29' 1" Long.....				
62 AJ	60 to 64 Levers, 31' 9½" Long				
62 AK	68 Levers, 34' 6" Long.....				
62 AL	72 to 76 Levers, 37' 2½" Long				
62 AM	80 Levers, 39' 11" Long.....				
62 AN	84 to 88 Levers, 42' 7½" Long				
62 AP	92 to 96 Levers, 45' 4" Long				
62 AR	100 to 104 Levers, 50' 9" Long.....				
	(Prices on Application)				



STYLE "K" SIGNAL TOWER.

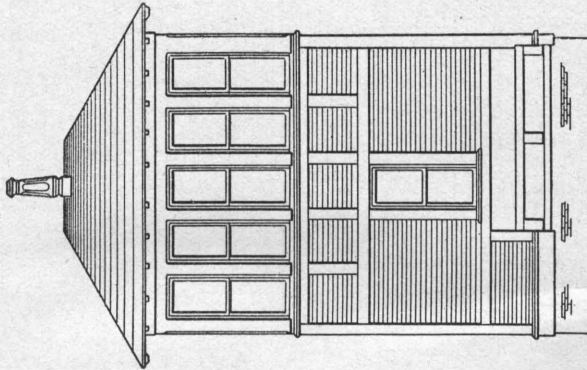
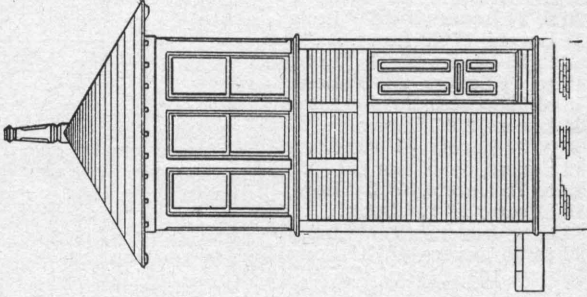

63AB

ORDER No.	63. SIGNAL TOWERS.	LIST PRICE	WEIGHT		
			LBS	OZS	
	Style "K" Signal Tower is 10 feet rail to floor, and will accommodate a Standard Interlocking Machine. This Tower is suitable for a Double Track Grade Crossing, also places where the space is limited.				
63 AA	4 to 12 Levers, 9' 4" x 12' 0".				
63 AB	16 Levers 9' 4" x 14' 8½".				
	(Prices on application.)				



## INDEX.

	Page
Adjustable Connector.....	338
Adjusting Screws, Point.....	200
"    "    Wire.....	338
Angle Bars.....	118
Anti-friction Vertical Wheels.....	214
Bars, Angle.....	118
"    Detector.....	176
Block and Train Order Signals.....	230
"    "    "    Signal Fittings.....	242
Block, Scotch.....	198
"    Station Levers.....	70
Bolt Locks.....	190
Box Cranks, Style "A".....	108
"    "    "    "B" Multiple.....	112
"    Wheels, Horizontal.....	224
"    Wrigley, Stuffing.....	338
Braces, Rail.....	188
Bracket Semaphore Signals.....	294
Bridge Couplers.....	194
"    Locks.....	192
"    Semaphore Signals.....	266
Carriers, Pipe.....	204
Chain.....	338
Clips, Rail.....	178
Compensating Dwarf Signals.....	310
Compensators, Pipe.....	116
"    Wire.....	334
Connector, Adjustable.....	338
Contents.....	5
Couplers, Bridge.....	194
Cranks, Box, Style "A".....	110
"    "    "    "B," Multiple.....	112
"    Horizontal.....	100
"    In Water-tight Boxes.....	114
"    Lead-out.....	108
"    Radial.....	118
"    Vertical.....	98
Cross Bars, Horizontal.....	104
"    "    Vertical.....	98

	Page
Detector Bars.....	176
"    Bar Stop and Guide.....	180
Distant Switch Signal.....	246
Draw Bridge Locks.....	192
Dwarf Machine, Style "C".....	50
"    "    "D".....	56
"    Signals, Compensating.....	310
"    Signal Fittings.....	320
"    Signals, Non-Compensating.....	306
Eyes, Wire.....	338
Facing Point Locks.....	120
Fittings, Dwarf Signals.....	320
"    Semaphore Signals.....	272
"    Train Order and Block Signals.....	242
Foundations.....	340
Front and Lock Rods.....	158
Glasses, Spectacle.....	290
Ground Semaphore Signals.....	248
Horizontal Cranks.....	100
"    Cross Bars.....	104
"    Wheels.....	218
"    "    Anti-friction.....	222
"    "    Box.....	224
Interlocking Machine, Style "A" (Standard).....	6
"    "    "    "B" (Saxby & Farmer).....	32
"    "    "    "C" (Dwarf).....	50
"    "    "    "D".....	56
"    "    "    "E" (Johnson).....	72
"    "    "    "F" (National).....	84
Jaws.....	200
Johnson, Style "E" Interlocking Machine.....	72
Lamps, Signal.....	292
Lead-out Cranks.....	108
Levers, Block Station.....	70
"    Table.....	68
"    Throw-over.....	62
Lock and Front Rods.....	158
Locks, Bolt.....	190
"    Draw Bridge.....	192
"    Facing Point.....	120
Lugs, Pipe.....	200
"    Point.....	172

	Page
Machine, Interlocking, Style "A" (Standard).....	6
"    "    "    "B" (Saxby & Farmer).....	32
"    "    "    "C" (Dwarf).....	50
"    "    "    "D".....	56
"    "    "    "E" (Johnson).....	72
"    "    "    "F" (National).....	84
"    Lever, for Block Stations.....	70
Mechanical Signal Slots.....	332
Movements, Switch and Lock.....	130
Multiple Box Cranks.....	112
National, Style "F" Interlocking Machine.....	84
Non-Compensating Dwarf Signals.....	306
Pins.....	200
Pipe and Fittings.....	210
"    Carriers.....	204
"    Compensators.....	116
"    Lugs.....	200
Point Adjusting Screws.....	200
"    Lugs.....	172
Pot Signals.....	324
Preface.....	3
Pulleys, Wire.....	336
Radial Cranks.....	118
Rail Braces.....	188
"    Clips.....	178
Rocking Shafts.....	94
Rods, Front and Lock.....	158
Saxby and Farmer Style "B," Interlocking Machine.....	32
Scotch Block.....	198
Screws, Point Adjusting.....	200
Screw, Wire Adjusting.....	338
Selectors.....	328
Semaphore Signals, Bracket.....	294
"    "    Bridge.....	266
"    "    Ground.....	248
"    Signal Fittings.....	272
Shackles.....	10
Shafts, Rocking.....	94
Signal, Distant Switch.....	246
"    Dwarf, Compensating.....	310
"    "    Fittings.....	320
"    "    Non-Compensating.....	306
"    Lamps.....	292
"    Pot.....	324
"    Semaphore, Bracket.....	294
"    "    Bridge.....	266
"    "    Ground.....	248
"    "    Fittings.....	272



	Page
Signal, Slots, Mechanical.....	332
“ Train Order and Block.....	230
“ “ “ “ Fittings.....	242
“ Towers.....	348
“ Wheels.....	228
Slots, Signal, Mechanical.....	332
Spectacle Glasses.....	290
Split Links.....	338
Standard, Style “A,” Interlocking Machine.....	6
Stop and Guide, Detector Bar.....	180
Stuffing Box, Wrigley.....	338
Style “A” (Standard) Interlocking Machine.....	6
“ “B” (Saxby and Farmer) Interlocking Machine.....	32
“ “C” (Dwarf) Interlocking Machine.....	50
“ “D” “ “ “ “.....	56
“ “E” (Johnson) “ “.....	72
“ “F” (National) “ “.....	84
Switch and Lock Movements.....	130
“ Distant, Signal.....	246
“ Lugs.....	172
Table Levers.....	68
Throw-over Levers.....	62
Towers, Signal.....	348
Train Order and Block Signals.....	230
“ “ “ “ Signal Fittings.....	242
Vertical Cranks.....	98
“ Cross Bars.....	98
“ Wheels.....	212
“ “ Anti-friction.....	214
Water-tight Boxes for Cranks.....	114
Wheels, Horizontal.....	218
“ “ Anti-friction.....	222
“ “ Box.....	224
“ Signal.....	228
“ Vertical.....	212
“ “ Anti-friction.....	214
Wire.....	338
“ Adjusting Screws.....	338
“ Compensator.....	334
“ Eyes.....	338
“ Pulleys.....	336
Wrigley Stuffing Box.....	338

